

SYLVANIA

SERVICE MANUAL

37" LCD TV/DVD LD370SS8

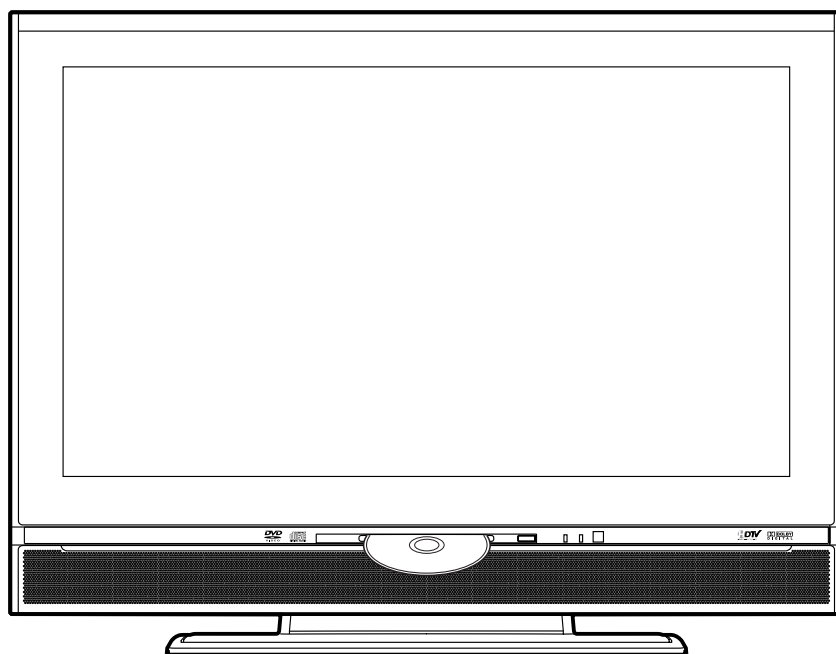

IMPORTANT SAFETY NOTICE

Proper service and repair is important to the safe, reliable operation of all Funai Equipment. The service procedures recommended by Funai and described in this service manual are effective methods of performing service operations. Some of these service special tools should be used when and as recommended.

It is important to note that this service manual contains various CAUTIONS and NOTICES which should be carefully read in order to minimize the risk of personal injury to service personnel. The possibility exists that improper service methods may damage the equipment. It also is important to understand that these CAUTIONS and NOTICES ARE NOT EXHAUSTIVE. Funai could not possibly know, evaluate and advice the service trade of all conceivable ways in which service might be done or of the possible hazardous consequences of each way. Consequently, Funai has not undertaken any such broad evaluation. Accordingly, a servicer who uses a service procedure or tool which is not recommended by Funai must first use all precautions thoroughly so that neither his safety nor the safe operation of the equipment will be jeopardized by the service method selected.

The LCD panel is manufactured to provide many years of useful life. Occasionally a few non active pixels may appear as a tiny spec of color. This is not to be considered a defect in the LCD screen.

Manufactured under license from Dolby Laboratories.
“Dolby” and the double-D symbol are trademarks of Dolby Laboratories.

TABLE OF CONTENTS

Specifications	1-1
Laser Beam Safety Precautions	2-1
Important Safety Precautions	3-1
Standard Notes for Servicing	4-1
Cabinet Disassembly Instructions	5-1
Electrical Adjustment Instructions	6-1
How to Initialize the LCD TV/DVD	7-1
Firmware Renewal Mode	8-1
Block Diagrams	9-1
Schematic Diagrams / CBA's and Test Points	10-1
Waveforms	11-1
Wiring Diagram	12-1
System Control Timing Charts	13-1
Lead Identifications	14-1
Exploded Views	15-1
Mechanical Parts List	16-1
Electrical Parts List	17-1

SPECIFICATIONS

< LCD TV Section >

< TUNER / NTSC >

ANT. Input ----- 75 ohm Unbal., F type

Description	Condition	Unit	Nominal	Limit
1. AFT Pull-in Range	---	MHz	±2.3	±2.1
2. Synchronizing Sens.	TV.ch.4	dBμ	---	20
	CA.ch.31	dBμ	---	20
	CA.ch.87	dBμ	---	23

< TUNER / ATSC >

Description	Condition	Unit	Nominal	Limit
1. Received Freq. Range (-28dBm)	---	kHz	---	±100
2. ATSC Dynamic Range (min / max)	ch.4	dBm	---	-76/0
	ch.10	dBm	---	-76/0
	ch.41	dBm	---	-76/0

< LCD PANEL >

Description	Condition	Unit	Nominal	Limit
1. Native Pixel Resolution	Horizontal	pixels	1366	---
	Vertical	pixels	768	---
2. Brightness (w / filter)	---	cd/m ²	320	---
3. Viewing Angle	Horizontal	°	-85 to 85	---
	Vertical	°	-85 to 85	---

< VIDEO >

Description	Condition	Unit	Nominal	Limit
1. Over Scan	Horizontal	%	6	6±5
	Vertical	%	6	6±5
2. Color Temperature	---	°K	12000	---
	x		0.272	±10%
	y		0.278	±10%
3. Resolution (composite video)	Horizontal	line	400	---
	Vertical	line	350	---

< AUDIO >

All items are measured across 8 Ω load at speaker output terminal with L.P.F. / Video1 Input.

Description	Condition	Unit	Nominal	Limit
1. Audio Output Power	-6dB: Lch/Rch	W	10.0/10.0	9.0/9.0
2. Audio Distortion	500mW: Lch/Rch	%	0.5/0.5	2.0/2.0
3. Audio Freq. Response (NTSC)	-6dB: Lch	Hz	70 to 10 k	---
	-6dB: Rch	Hz	70 to 10 k	---

<DVD Section>

< DVD >

Description	Condition	Unit	Nominal	Limit
1. Horizontal Resolution (TDV-540 TIT.2 CHP.16)	---	Line	350	330
2. Video S/N (TDV-540 TIT.2 CHP.6)	---	dB	60	55
3. Audio Distortion (LPCM 48 kHz, W/LPF) (PTD 1-NOR TIT.1 CHP.1)	L R	%	0.03	0.07
4. Audio freq. response (LPCM 48 kHz) (PTD 1-NOR TIT.1 CHP.5 -- 10)	L, 20 Hz R, 20 Hz L, 20 kHz R, 20 kHz	dB	0	+4/-5
5. Audio S/N (LPCM 48 kHz, W/LPF, A-WTD) (PTD 1-NOR TIT.1 CHP.1 -- 2)	L R	dB	85	75

Note: Nominal specifications represent the design specifications. All units should be able to approximate these. Some will exceed and some may drop slightly below these specifications. Limit specifications represent the absolute worst condition that still might be considered acceptable. In no case should a unit fail to meet limit specifications.

LASER BEAM SAFETY PRECAUTIONS

This DVD player uses a pickup that emits a laser beam.

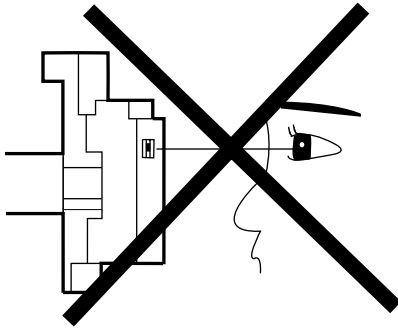

Do not look directly at the laser beam coming from the pickup or allow it to strike against your skin.

The laser beam is emitted from the location shown in the figure. When checking the laser diode, be sure to keep your eyes at least 30 cm away from the pickup lens when the diode is turned on. Do not look directly at the laser beam.

CAUTION: Use of controls and adjustments, or doing procedures other than those specified herein, may result in hazardous radiation exposure.

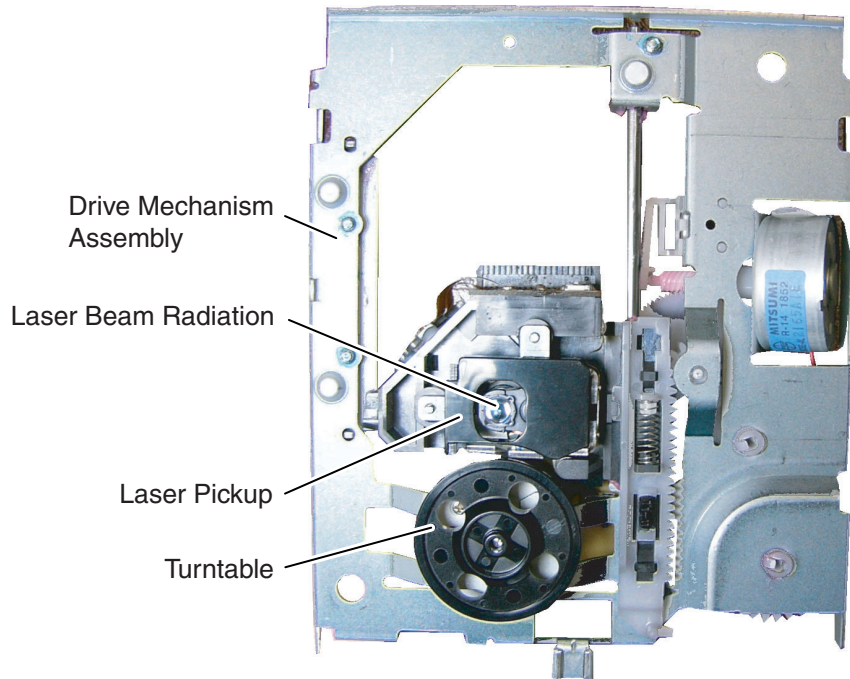

CAUTION
LASER RADIATION
WHEN OPEN. DO NOT
STARE INTO BEAM.

Location: Top of DVD mechanism.

IMPORTANT SAFETY PRECAUTIONS

Prior to shipment from the factory, our products are strictly inspected for recognized product safety and electrical codes of the countries in which they are to be sold. However, in order to maintain such compliance, it is equally important to implement the following precautions when a set is being serviced.

Safety Precautions for LCD TV Circuit

1. Before returning an instrument to the

customer, always make a safety check of the entire instrument, including, but not limited to, the following items:

a. Be sure that no built-in protective devices are defective and have been defeated during servicing. (1) Protective shields are provided on this chassis to protect both the technician and the customer. Correctly replace all missing protective shields, including any removed for servicing convenience. (2) When reinstalling the chassis and/or other assembly in the cabinet, be sure to put back in place all protective devices, including but not limited to, nonmetallic control knobs, insulating fishpapers, adjustment and compartment covers/shields, and isolation resistor/capacitor networks. **Do not operate this instrument or permit it to be operated without all protective devices correctly installed and functioning. Servicers who defeat safety features or fail to perform safety checks may be liable for any resulting damage.**

b. Be sure that there are no cabinet openings through which an adult or child might be able to insert their fingers and contact a hazardous voltage. Such openings include, but are not limited to, (1) spacing between the Liquid Crystal Panel and the cabinet mask, (2) excessively wide cabinet ventilation slots, and (3) an improperly fitted and/or incorrectly secured cabinet back cover.

c. Antenna Cold Check - With the instrument AC plug removed from any AC source, connect an electrical jumper across the two AC plug prongs. Place the instrument AC switch in the on position. Connect one lead of an ohmmeter to the AC plug prongs tied together and touch the other ohmmeter lead in turn to each tuner antenna input exposed terminal screw and, if applicable, to the coaxial connector. If the measured resistance is less than 1.0 megohm or greater than 5.2 megohm, an abnormality exists that must be corrected before the instrument is returned to the customer. Repeat this test with the instrument AC switch in the off position.

d. Leakage Current Hot Check - With the instrument completely reassembled, plug the AC line cord directly into a 120 V AC outlet. (Do not use an isolation transformer during this test.) Use a leakage current tester or a metering system that complies with American National Standards Institute (ANSI) C101.1 Leakage Current for Appliances and Underwriters Laboratories (UL) 1410, (50.7). With the instrument AC switch first in the on position and then in the off position, measure from a known earth ground (metal water pipe, conduit, etc.) to all exposed metal parts of the instrument (antennas, handle brackets, metal cabinet, screw heads, metallic overlays, control shafts, etc.), especially any exposed metal parts that offer an electrical return path to the chassis. Any current measured must not exceed 0.5 milli-ampere. Reverse the instrument power cord plug in the outlet and repeat the test.

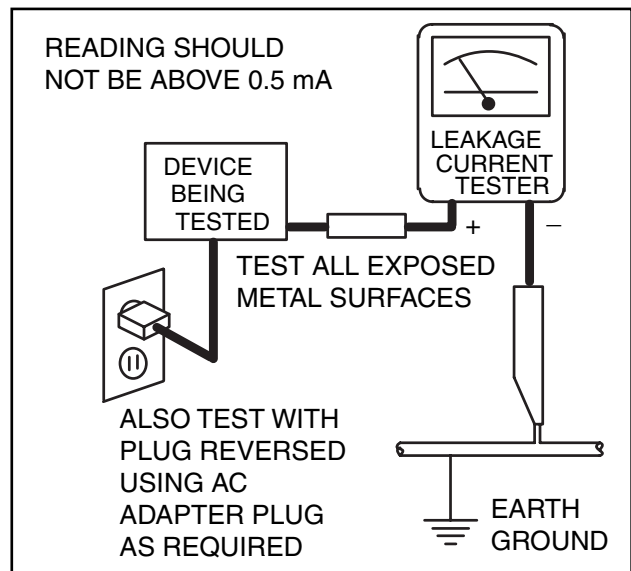

ANY MEASUREMENTS NOT WITHIN THE LIMITS SPECIFIED HEREIN INDICATE A POTENTIAL SHOCK HAZARD THAT MUST BE ELIMINATED BEFORE RETURNING THE INSTRUMENT TO THE CUSTOMER OR BEFORE CONNECTING THE ANTENNA OR ACCESSORIES.

2. Read and comply with all caution and safety-related notes on or inside the receiver cabinet, on the receiver chassis, or on the Liquid Crystal Panel.

- 3. Design Alteration Warning** - Do not alter or add to the mechanical or electrical design of this TV receiver. Design alterations and additions, including, but not limited to circuit modifications and the addition of items such as auxiliary audio and/or video output connections, might alter the safety characteristics of this receiver and create a hazard to the user. Any design alterations or additions will void the manufacturer's warranty and may make you, the servicer, responsible for personal injury or property damage resulting therefrom.
- 4. Hot Chassis Warning** -
 - a. Some TV receiver chassis are electrically connected directly to one conductor of the AC power cord and maybe safety-serviced without an isolation transformer only if the AC power plug is inserted so that the chassis is connected to the ground side of the AC power source. To confirm that the AC power plug is inserted correctly, with an AC voltmeter, measure between the chassis and a known earth ground. If a voltage reading in excess of 1.0 V is obtained, remove and reinsert the AC power plug in the opposite polarity and again measure the voltage potential between the chassis and a known earth ground.
 - b. Some TV receiver chassis normally have 85V AC(RMS) between chassis and earth ground regardless of the AC plug polarity. This chassis can be safety-serviced only with an isolation transformer inserted in the power line between the receiver and the AC power source, for both personnel and test equipment protection.
 - c. Some TV receiver chassis have a secondary ground system in addition to the main chassis ground. This secondary ground system is not isolated from the AC power line. The two ground systems are electrically separated by insulation material that must not be defeated or altered.
- 5.** Observe original lead dress. Take extra care to assure correct lead dress in the following areas: a. near sharp edges, b. near thermally hot parts-be sure that leads and components do not touch thermally hot parts, c. the AC supply, d. high voltage, and, e. antenna wiring. Always inspect in all areas for pinched, out of place, or frayed wiring. Check AC power cord for damage.
- 6.** Components, parts, and/or wiring that appear to have overheated or are otherwise damaged should be replaced with components, parts, or wiring that meet original specifications. Additionally, determine the cause of overheating and/or damage and, if necessary, take corrective action to remove any potential safety hazard.
- 7. Product Safety Notice** - Some electrical and mechanical parts have special safety-related characteristics which are often not evident from visual inspection, nor can the protection they give necessarily be obtained by replacing them with components rated for higher voltage, wattage, etc. Parts that have special safety characteristics are identified by a  on schematics and in parts lists. Use of a substitute replacement that does not have the same safety characteristics as the recommended replacement part might create shock, fire, and/or other hazards. The product's safety is under review continuously and new instructions are issued whenever appropriate. Prior to shipment from the factory, our products are strictly inspected to confirm they comply with the recognized product safety and electrical codes of the countries in which they are to be sold. However, in order to maintain such compliance, it is equally important to implement the following precautions when a set is being serviced.

Precautions during Servicing

- A.** Parts identified by the **▲** symbol are critical for safety.
Replace only with part number specified.
- B.** In addition to safety, other parts and assemblies are specified for conformance with regulations applying to spurious radiation. These must also be replaced only with specified replacements.
Examples: RF converters, RF cables, noise blocking capacitors, and noise blocking filters, etc.
- C.** Use specified internal wiring. Note especially:
 - 1) Wires covered with PVC tubing
 - 2) Double insulated wires
 - 3) High voltage leads
- D.** Use specified insulating materials for hazardous live parts. Note especially:
 - 1) Insulation Tape
 - 2) PVC tubing
 - 3) Spacers
 - 4) Insulators for transistors.
- E.** When replacing AC primary side components (transformers, power cord, etc.), wrap ends of wires securely about the terminals before soldering.
- F.** Observe that the wires do not contact heat producing parts (heat sinks, oxide metal film resistors, fusible resistors, etc.)
- G.** Check that replaced wires do not contact sharp edged or pointed parts.
- H.** When a power cord has been replaced, check that 5~6 kg of force in any direction will not loosen it.
- I.** Also check areas surrounding repaired locations.
- J.** Use care that foreign objects (screws, solder droplets, etc.) do not remain inside the set.
- K.** When connecting or disconnecting the internal connectors, first, disconnect the AC plug from the AC supply outlet.
- L.** When installing parts or assembling the cabinet parts, be sure to use the proper screws and tighten certainly.

Safety Check after Servicing

Examine the area surrounding the repaired location for damage or deterioration. Observe that screws, parts and wires have been returned to original positions. Afterwards, perform the following tests and confirm the specified values in order to verify compliance with safety standards.

1. Clearance Distance

When replacing primary circuit components, confirm specified clearance distance (d) and (d') between soldered terminals, and between terminals and surrounding metallic parts. (See Fig. 1)

Table 1: Ratings for selected area

AC Line Voltage	Region	Clearance Distance (d), (d')
110 to 130 V	U.S.A. or Canada	≥ 3.2 mm (0.126 inches)

Note: This table is unofficial and for reference only. Be sure to confirm the precise values.

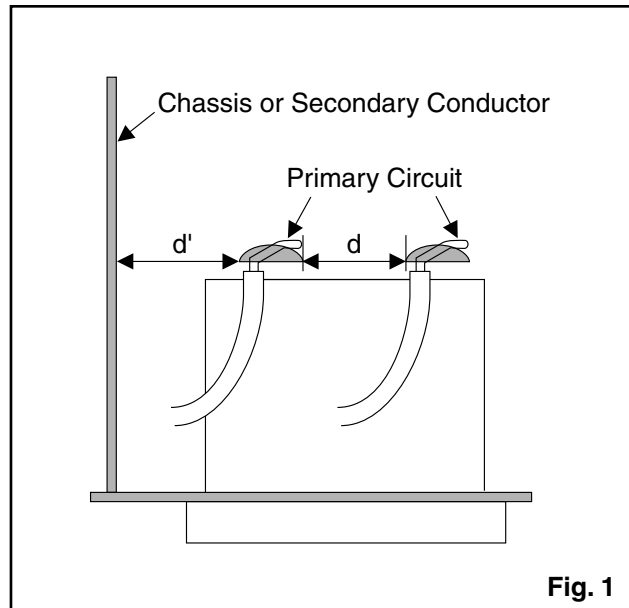

Fig. 1

2. Leakage Current Test

Confirm the specified (or lower) leakage current between B (earth ground, power cord plug prongs) and externally exposed accessible parts (RF terminals, antenna terminals, video and audio input and output terminals, microphone jacks, earphone jacks, etc.) is lower than or equal to the specified value in the table below.

Measuring Method: (Power ON)

Insert load Z between B (earth ground, power cord plug prongs) and exposed accessible parts. Use an AC voltmeter to measure across both terminals of load Z. See Fig. 2 and following table.

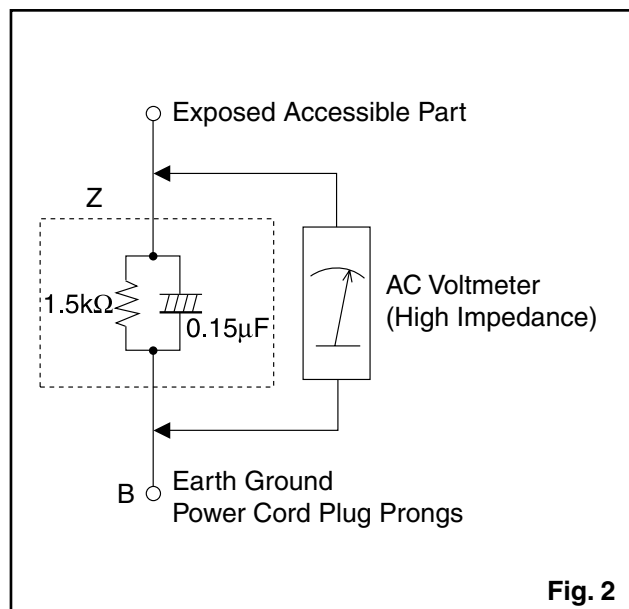

Fig. 2

Table 2: Leakage current ratings for selected areas

AC Line Voltage	Region	Load Z	Leakage Current (i)	Earth Ground (B) to:
110 to 130 V	U.S.A. or Canada	0.15 μF CAP. & 1.5 kΩ RES. Connected in parallel	$i \leq 0.5$ mA rms	Exposed accessible parts

Note: This table is unofficial and for reference only. Be sure to confirm the precise values.

STANDARD NOTES FOR SERVICING

Circuit Board Indications

1. The output pin of the 3 pin Regulator ICs is indicated as shown.

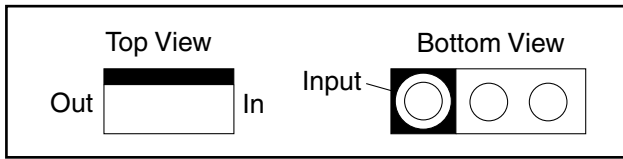

2. For other ICs, pin 1 and every fifth pin are indicated as shown.

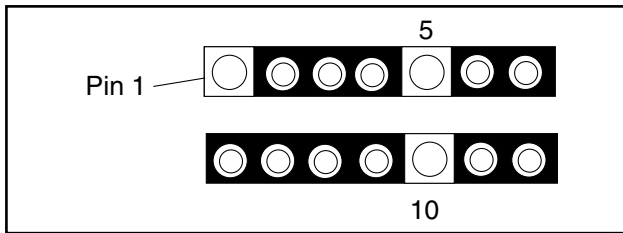

3. The 1st pin of every male connector is indicated as shown.

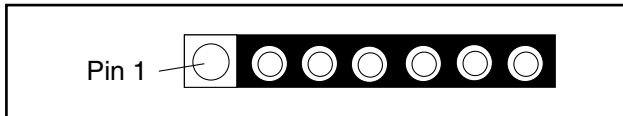

Instructions for Connectors

1. When you connect or disconnect the FFC (Flexible Foil Connector) cable, be sure to first disconnect the AC cord.
2. FFC (Flexible Foil Connector) cable should be inserted parallel into the connector, not at an angle.

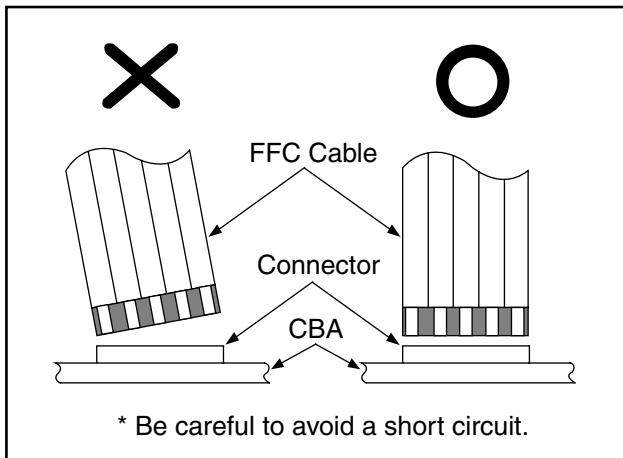

Pb (Lead) Free Solder

Pb free mark will be found on PCBs which use Pb free solder. (Refer to figure.) For PCBs with Pb free mark, be sure to use Pb free solder. For PCBs without Pb free mark, use standard solder.

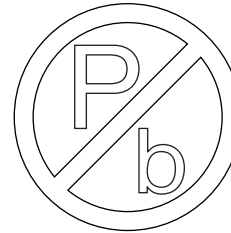

Pb free mark

How to Remove / Install Flat Pack-IC

1. Removal

With Hot-Air Flat Pack-IC Desoldering Machine:

1. Prepare the hot-air flat pack-IC desoldering machine, then apply hot air to the Flat Pack-IC (about 5 to 6 seconds). (Fig. S-1-1)

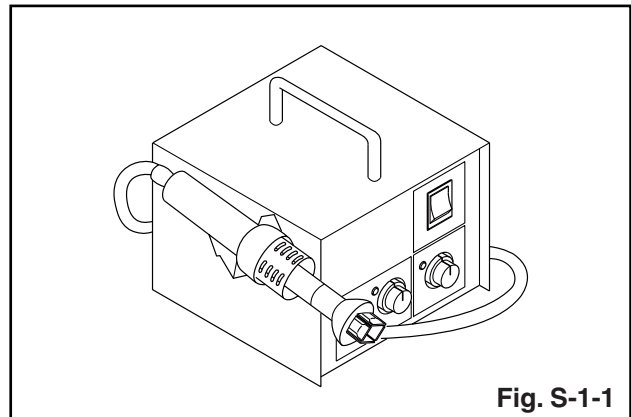

Fig. S-1-1

2. Remove the flat pack-IC with tweezers while applying the hot air.
3. Bottom of the flat pack-IC is fixed with glue to the CBA; when removing entire flat pack-IC, first apply soldering iron to center of the flat pack-IC and heat up. Then remove (glue will be melted). (Fig. S-1-6)
4. Release the flat pack-IC from the CBA using tweezers. (Fig. S-1-6)

CAUTION:

1. The Flat Pack-IC shape may differ by models. Use an appropriate hot-air flat pack-IC desoldering machine, whose shape matches that of the Flat Pack-IC.
2. Do not supply hot air to the chip parts around the flat pack-IC for over 6 seconds because damage to the chip parts may occur. Put masking tape

around the flat pack-IC to protect other parts from damage. (Fig. S-1-2)

3. The flat pack-IC on the CBA is affixed with glue, so be careful not to break or damage the foil of each pin or the solder lands under the IC when removing it.

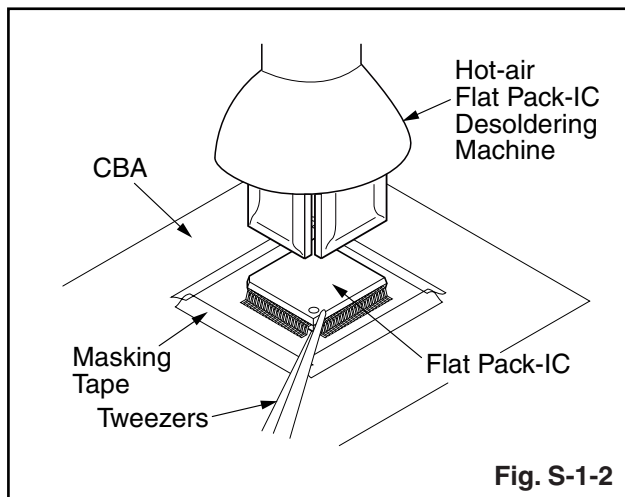

With Soldering Iron:

1. Using desoldering braid, remove the solder from all pins of the flat pack-IC. When you use solder flux which is applied to all pins of the flat pack-IC, you can remove it easily. (Fig. S-1-3)

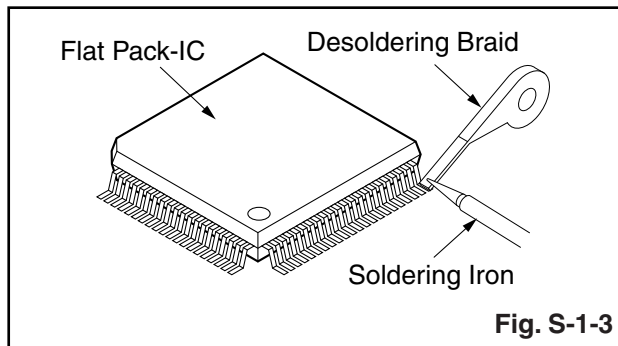

2. Lift each lead of the flat pack-IC upward one by one, using a sharp pin or wire to which solder will not adhere (iron wire). When heating the pins, use a fine tip soldering iron or a hot air desoldering machine. (Fig. S-1-4)

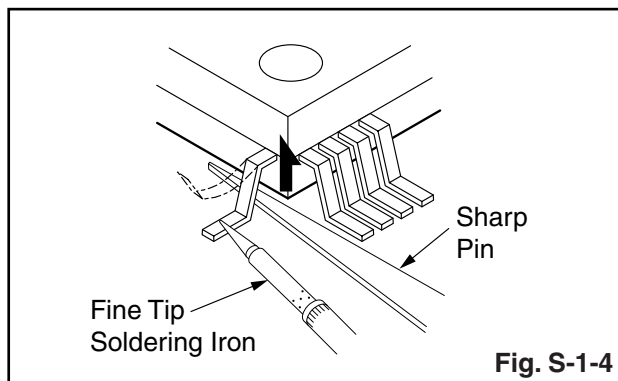

3. Bottom of the flat pack-IC is fixed with glue to the CBA; when removing entire flat pack-IC, first apply soldering iron to center of the flat pack-IC and heat up. Then remove (glue will be melted). (Fig. S-1-6)
4. Release the flat pack-IC from the CBA using tweezers. (Fig. S-1-6)

With Iron Wire:

1. Using desoldering braid, remove the solder from all pins of the flat pack-IC. When you use solder flux which is applied to all pins of the flat pack-IC, you can remove it easily. (Fig. S-1-3)
2. Affix the wire to a workbench or solid mounting point, as shown in Fig. S-1-5.
3. While heating the pins using a fine tip soldering iron or hot air blower, pull up the wire as the solder melts so as to lift the IC leads from the CBA contact pads as shown in Fig. S-1-5.
4. Bottom of the flat pack-IC is fixed with glue to the CBA; when removing entire flat pack-IC, first apply soldering iron to center of the flat pack-IC and heat up. Then remove (glue will be melted). (Fig. S-1-6)
5. Release the flat pack-IC from the CBA using tweezers. (Fig. S-1-6)

Note: When using a soldering iron, care must be taken to ensure that the flat pack-IC is not being held by glue. When the flat pack-IC is removed from the CBA, handle it gently because it may be damaged if force is applied.

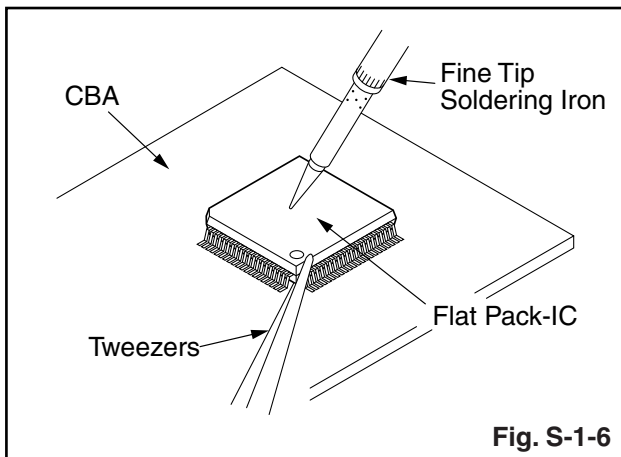
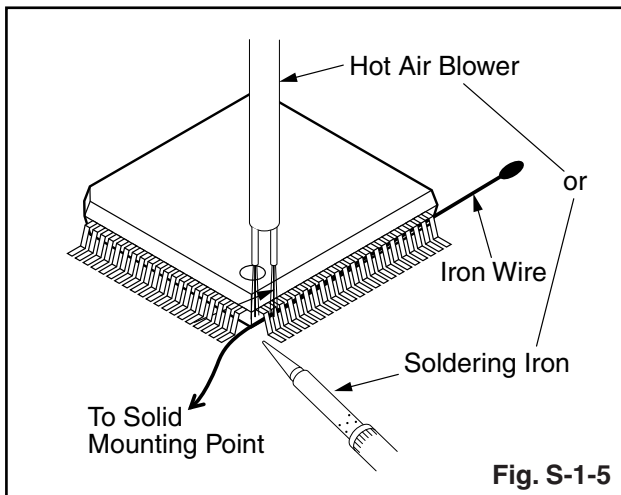

2. Installation

1. Using desoldering braid, remove the solder from the foil of each pin of the flat pack-IC on the CBA so you can install a replacement flat pack-IC more easily.
2. The "●" mark on the flat pack-IC indicates pin 1. (See Fig. S-1-7.) Be sure this mark matches the 1 on the PCB when positioning for installation. Then presolder the four corners of the flat pack-IC. (See Fig. S-1-8.)
3. Solder all pins of the flat pack-IC. Be sure that none of the pins have solder bridges.

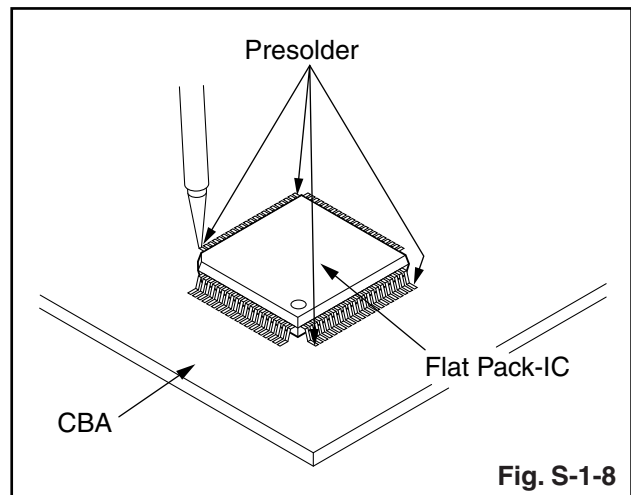
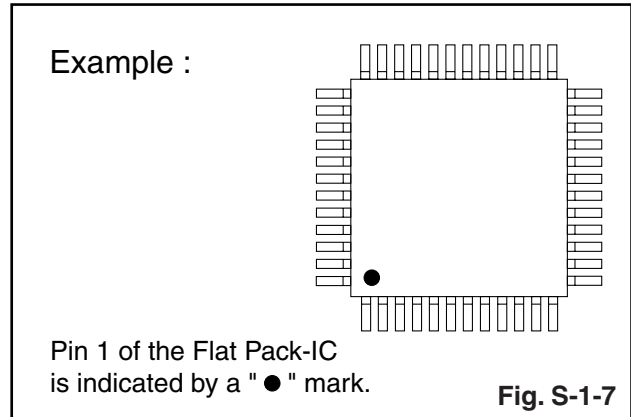

Instructions for Handling Semi-conductors

Electrostatic breakdown of the semi-conductors may occur due to a potential difference caused by electrostatic charge during unpacking or repair work.

1. Ground for Human Body

Be sure to wear a grounding band (1 M Ω) that is properly grounded to remove any static electricity that may be charged on the body.

2. Ground for Workbench

Be sure to place a conductive sheet or copper plate with proper grounding (1 M Ω) on the workbench or other surface, where the semi-conductors are to be placed. Because the static electricity charge on clothing will not escape through the body grounding band, be careful to avoid contacting semi-conductors with your clothing.

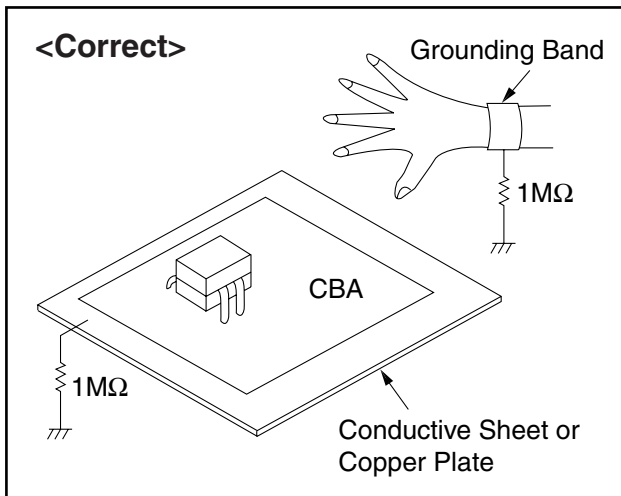
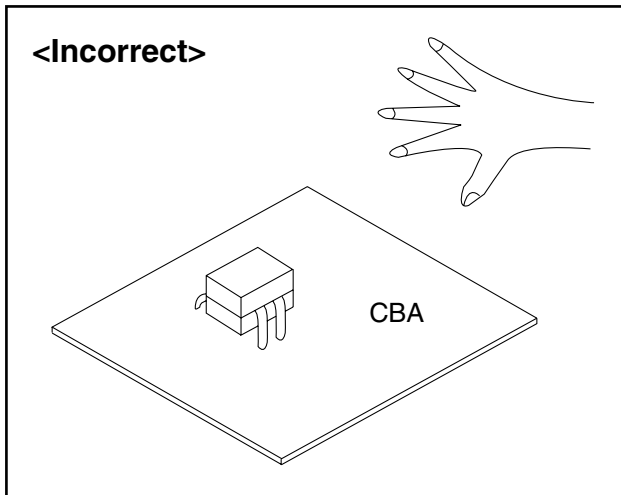

CABINET DISASSEMBLY INSTRUCTIONS

1. Disassembly Flowchart

This flowchart indicates the disassembly steps for the cabinet parts, and the CBA in order to gain access to item(s) to be serviced. When reassembling, follow the steps in reverse order. Bend, route and dress the cables as they were.

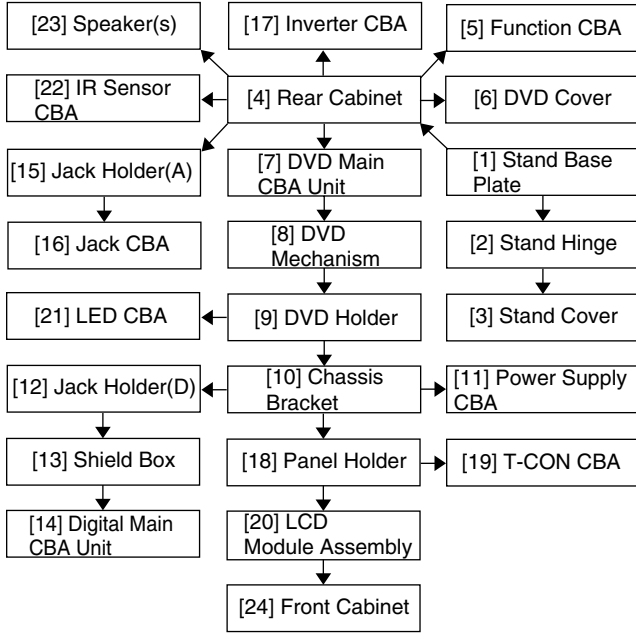

2. Disassembly Method

Step/ Loc. No.	Part	Removal		
		Fig. No.	Remove/*Unhook/ Unlock/Release/ Unplug/Unclamp/ Desolder	Note
[1]	Stand Base Plate	D1	4(S-1), 6(S-2), 5(S-3)	---
[2]	Stand Hinge	D1	-----	---
[3]	Stand Cover	D1	-----	---
[4]	Rear Cabinet	D1	11(S-4), 4(S-5)	---
[5]	Function CBA	D1 D6	3(S-6), *CN3002	---
[6]	DVD Cover	D1	4(S-7)	---
[7]	DVD Main CBA Unit	D2 D6	(S-8), *CN201, *CN301, *CN401, *CN601,*CN801	1
[8]	DVD Mechanism	D2	4(S-9)	2 3 4 5

Step/ Loc. No.	Part	Removal		
		Fig. No.	Remove/*Unhook/ Unlock/Release/ Unplug/Unclamp/ Desolder	Note
[9]	DVD Holder	D2	4(S-10)	---
[10]	Chassis Bracket	D3	16(S-11)	---
[11]	Power Supply CBA	D3 D6	4(S-12), *CN101B, *CN501, *CN801, *CN802, *CN3010, *CN3014 *CN3017	---
[12]	Jack Holder(D)	D3	(S-13), 2(S-14), 2(S-15), (N-1), Earth Plate	---
[13]	Shield Box	D3	5(S-16), *CN3001, Shield Plate	---
[14]	Digital Main CBA Unit	D3 D6	*CN3018, *CN3023	---
[15]	Jack Holder(A)	D4	(S-17)	---
[16]	Jack CBA	D4 D6	5(S-18)	---
[17]	Inverter CBA	D4 D6	8(S-19), *CN1050, *CN1100, *CN1150, *CN1200, *CN1250, *CN1300, *CN1350, *CN1400	---
[18]	Panel Holder	D4	8(S-20), 2(S-21)	---
[19]	T-CON CBA	D5 D6	4(S-22), *CN9001, *CN9002, *CN9005	---
[20]	LCD Module Assembly	D5	8(S-23)	---
[21]	LED CBA	D5 D6	2(S-24), *CN104	---
[22]	IR Sensor CBA	D5 D6	2(S-25)	---
[23]	Speaker(s)	D5	8(S-26)	---
[24]	Front Cabinet	D5	-----	---

↓ ↓ ↓ ↓ ↓
(1) (2) (3) (4) (5)

Note:

- (1) Order of steps in procedure. When reassembling, follow the steps in reverse order. These numbers are also used as the Identification (location) No. of parts in figures.
- (2) Parts to be removed or installed.
- (3) Fig. No. showing procedure of part location
- (4) Identification of parts to be removed, unhooked, unlocked, released, unplugged, unclamped, or desoldered.
P = Spring, L = Locking Tab, S = Screw,
CN = Connector
* = Unhook, Unlock, Release, Unplug, or Desolder
e.g. 2(S-2) = two Screws (S-2),
2(L-2) = two Locking Tabs (L-2)
- (5) Refer to the following "Reference Notes in the Table."

Reference Notes

1. **CAUTION 1:** Electrostatic breakdown of the laser diode in the optical system block may occur as a potential difference caused by electrostatic charge accumulated on cloth, human body etc., during unpacking or repair work.
To avoid damage of pickup follow next procedures.
 - 1) Short the three short lands of FPC cable with solder before removing the FFC cable (CN201) from it. If you disconnect the FFC cable (CN201), the laser diode of pickup will be destroyed. (Fig. D2)
 - 2) Disconnect Connectors (CN301), (CN401), (CN601) and (CN801). Remove Screw (S-8) and remove the DVD Main CBA Unit. (Fig. D2)
2. **Reassembly Notes of New DVD Mechanism:**
 - a. To remove the Chassis Cover, remove two screws A as shown in Fig. D2.
 - b. To avoid damage of the pickup unit (laser diode), confirm that the three short lands (either of two places) are shorted out by soldering between them as shown in View A in Fig. D2.
 - c. Connect the FFC cables of the new DVD Mechanism to the three connectors (CN201, CN301, CN801) on the DVD Main CBA Unit.
 - d. After confirming that the FFC cables are securely connected to the three connectors, remove the solder from the three short lands. If the solder is not removed, the laser diode will not light and it will not be possible to read discs.
 - e. Insert the pin A on the Chassis Cover into the hole A on the Main Chassis as shown in Fig. D2. Then tighten two screws A to install the Chassis Cover.
3. **CAUTION 2:** When reassembling, confirm the FFC cable (CN201) is connected completely. Then remove the solder from the three short lands of FPC cable. (Fig. D2)
4. **How to eject a disc in emergency**
Press and hold [EJECT] on the unit for more than 5 seconds.
5. **How to eject manually**
 - 1) Remove the Rear Cabinet and DVD Cover.
 - 2) To remove the DVD Main CBA Unit, remove a screw (S-8) in Fig. D2. Do not disconnect connectors.
 - 3) To remove the Chassis Cover, remove two screws A as shown in Fig. D2.
 - 4) Remove a disc

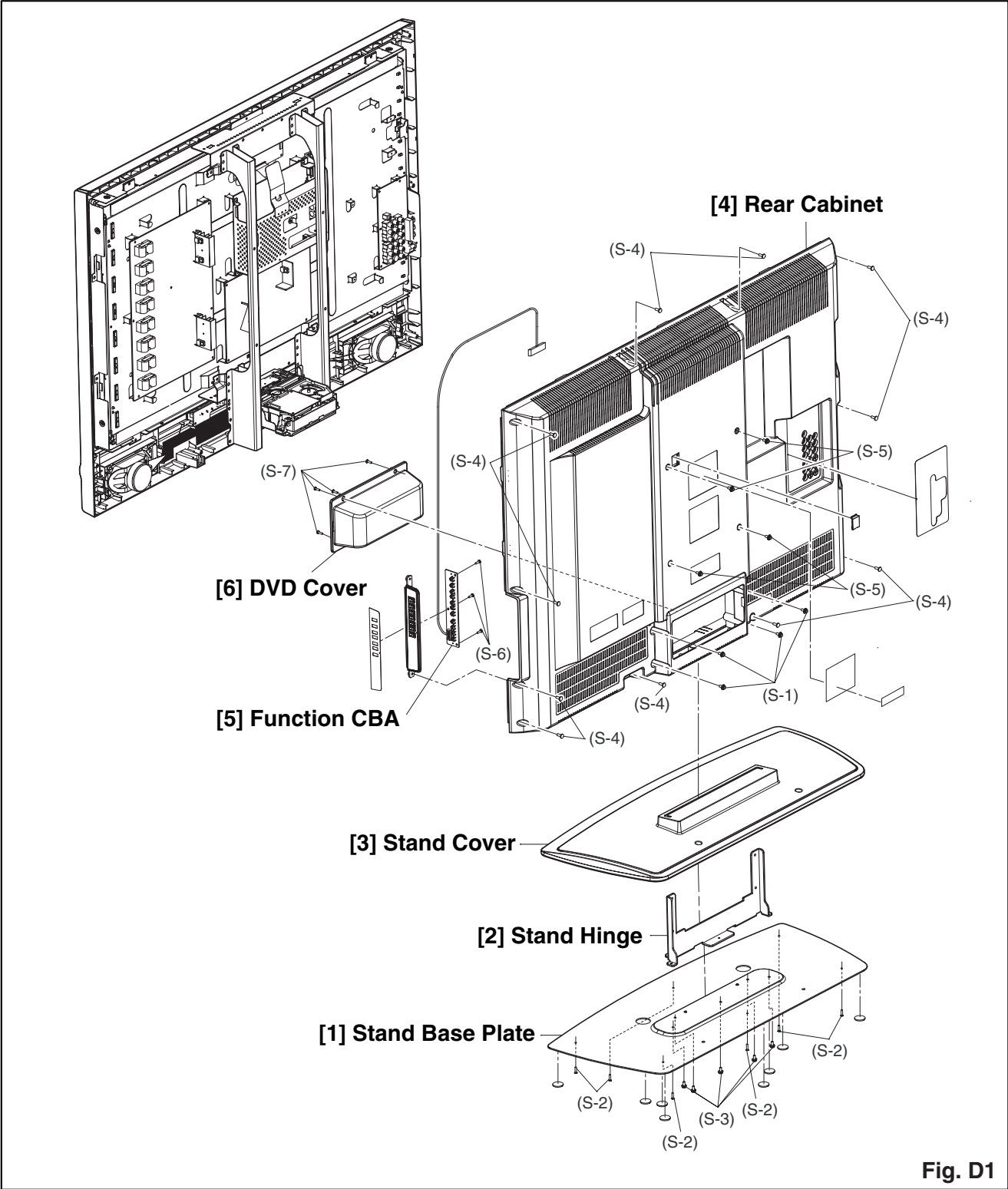
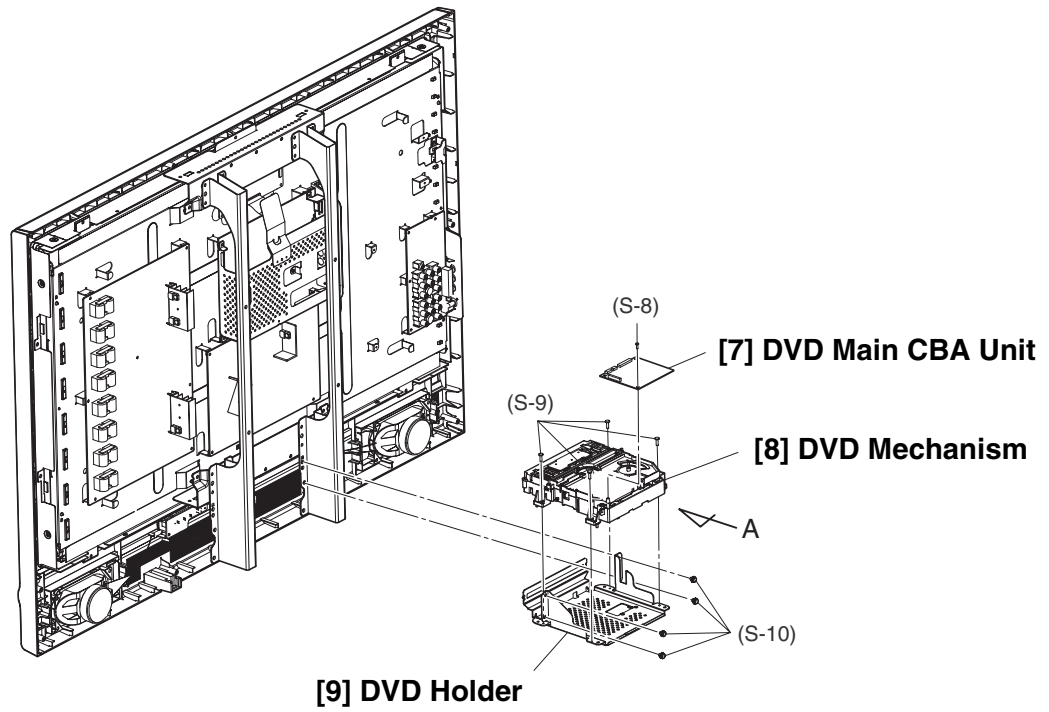

Fig. D1



Remove two screws A, then short the three short lands by soldering as shown in View for A.

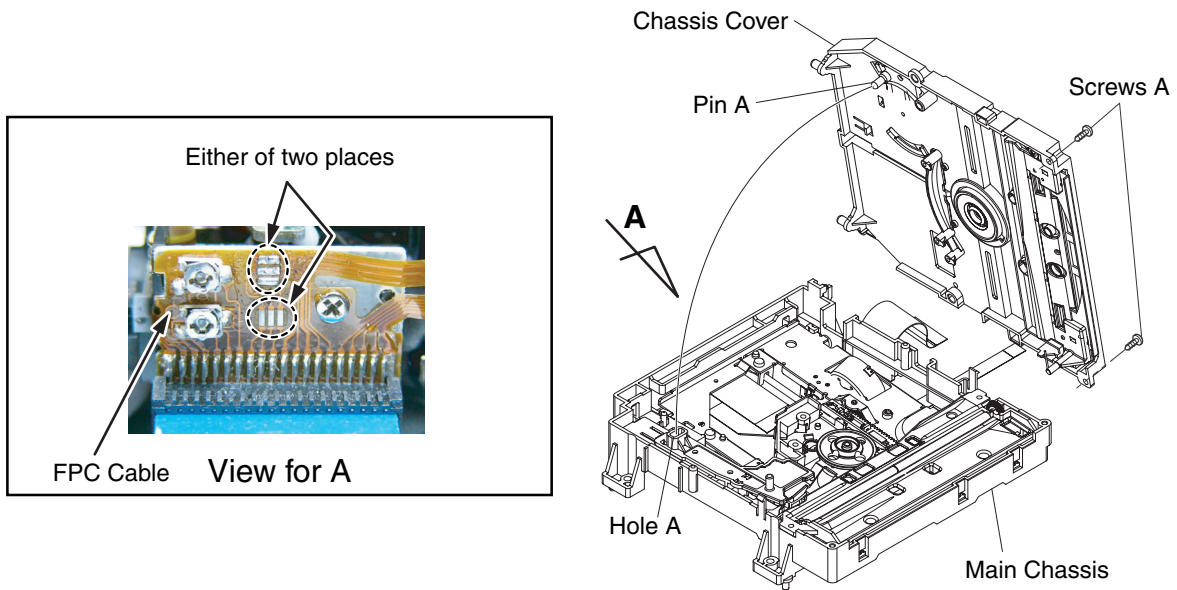
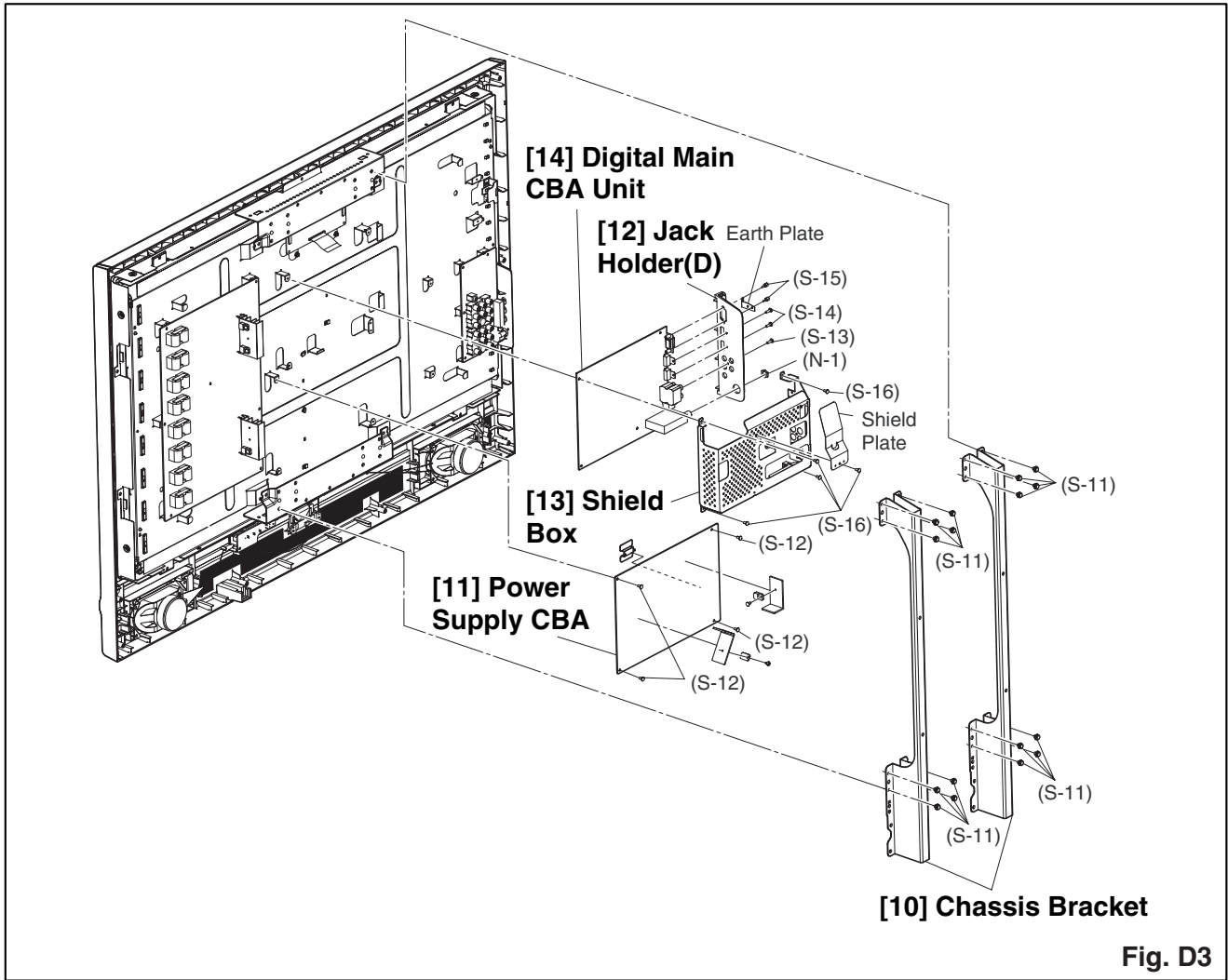

Fig. D2



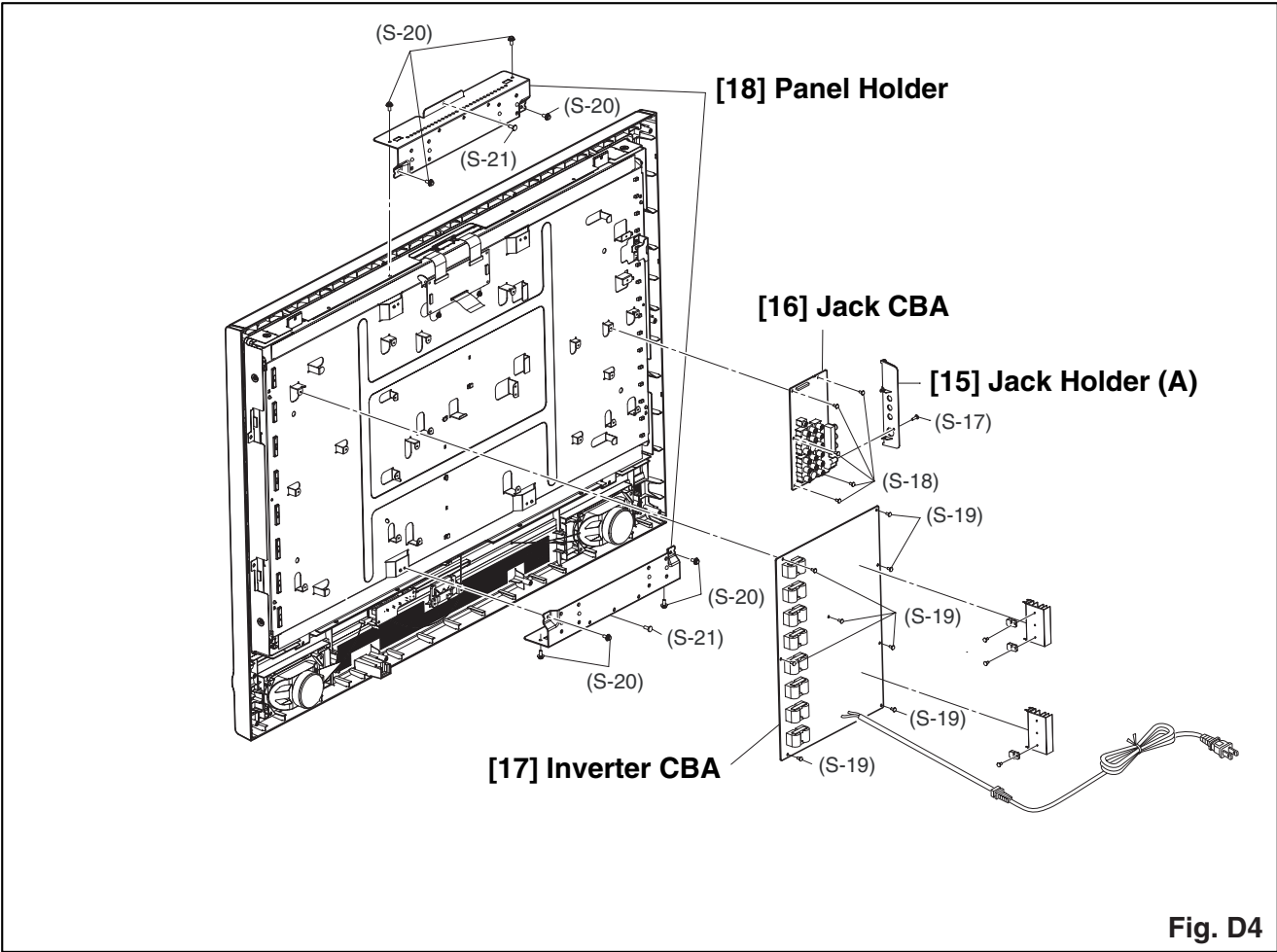

Fig. D4

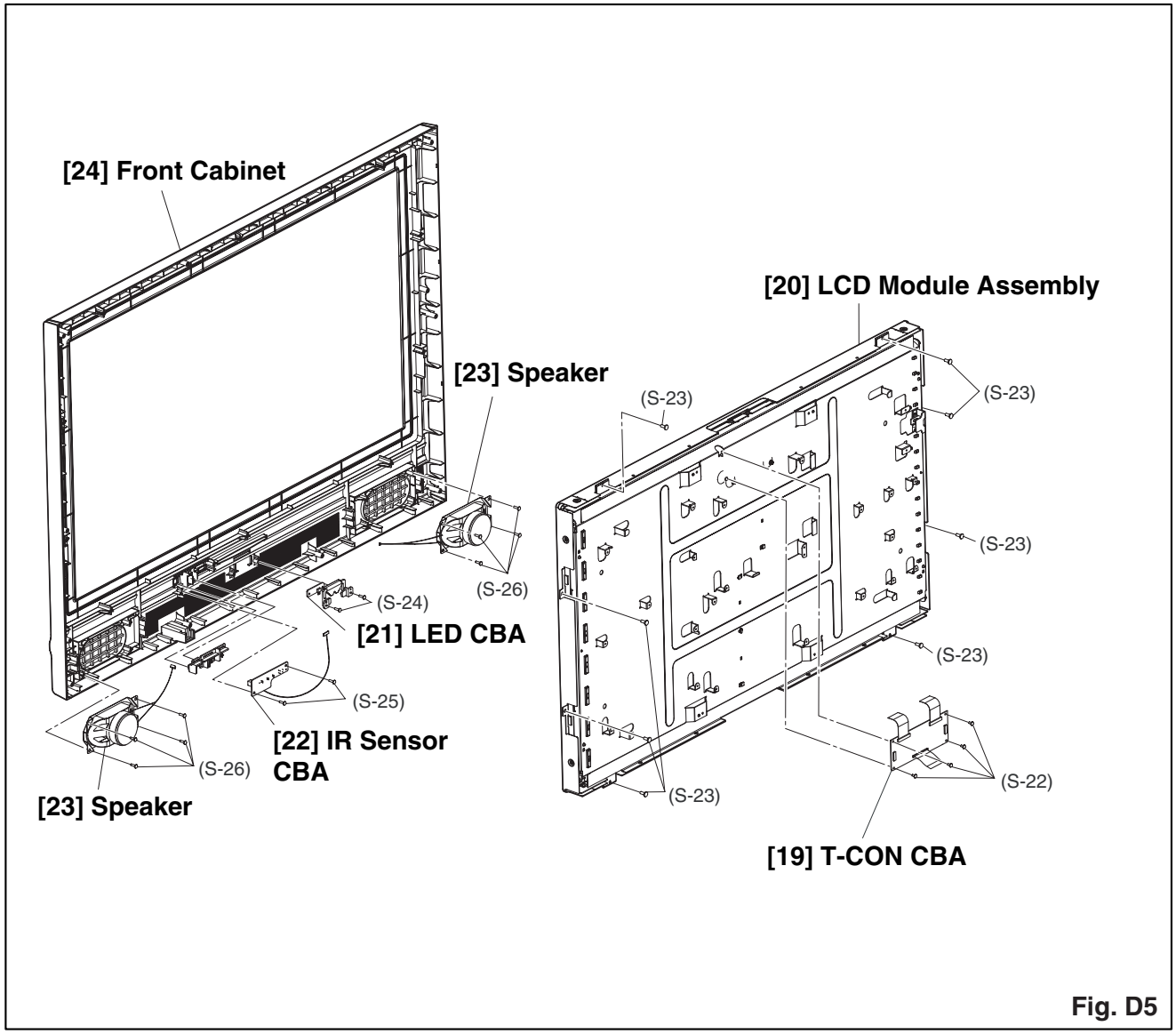

Fig. D5

TV Cable Wiring Diagram

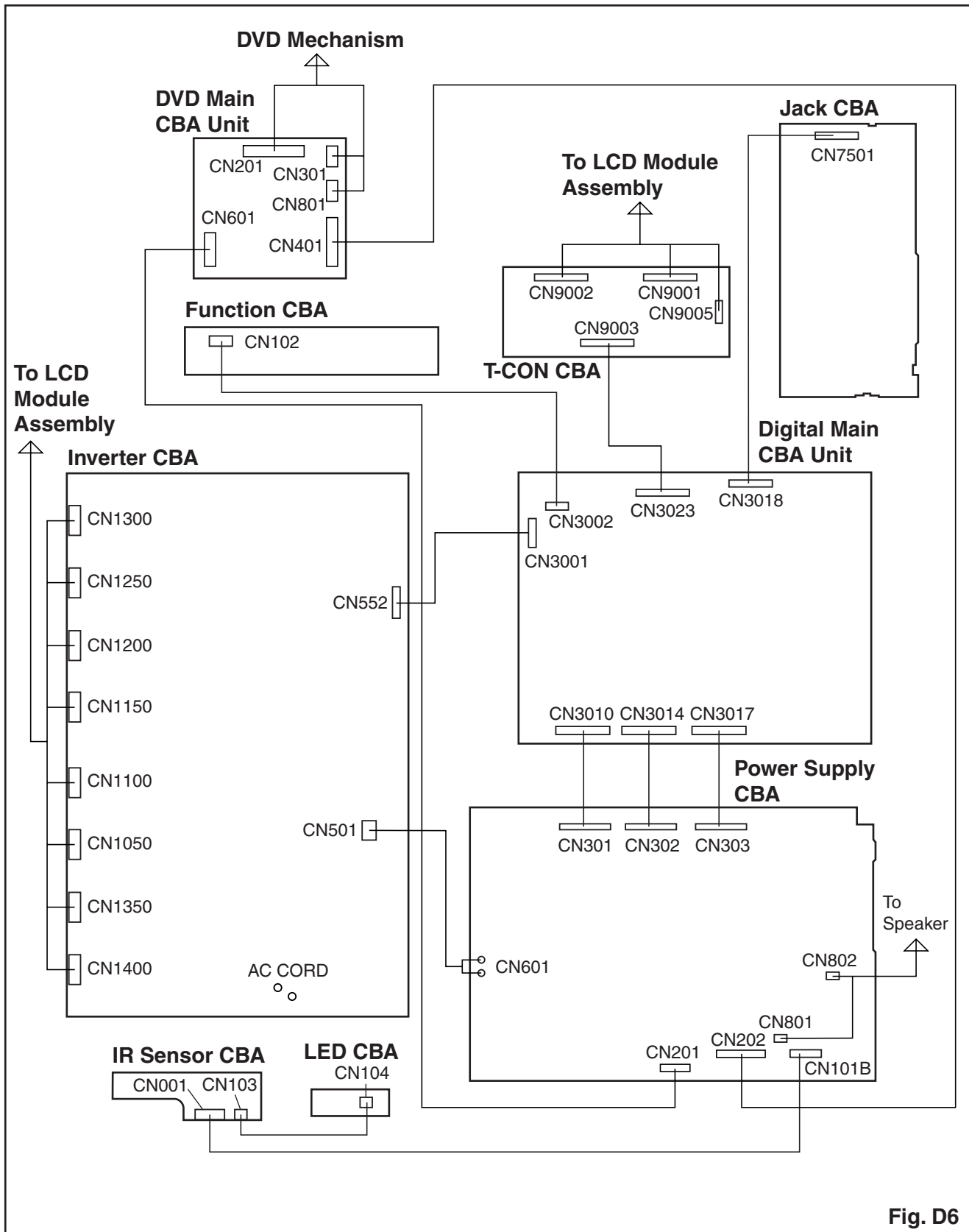

Fig. D6

ELECTRICAL ADJUSTMENT INSTRUCTIONS

General Note: “CBA” is abbreviation for “Circuit Board Assembly.”

Note: Electrical adjustments are required after replacing circuit components and certain mechanical parts. It is important to perform these adjustments only after all repairs and replacements have been completed. Also, do not attempt these adjustments unless the proper equipment is available.

Test Equipment Required

1. DC Voltmeter
2. NTSC Pattern Generator (Color Bar W/White Window, Red Color, Dot Pattern, Gray Scale, Monoscope, Multi-Burst)
3. Remote control unit
4. Color Analyzer

How to make the Service remote control unit:

Cut “A” portion of the attached remote control unit as shown in Fig. 1.

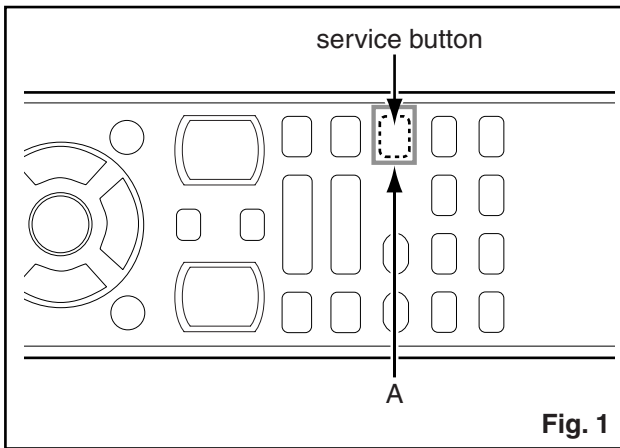

Fig. 1

How to set up the service mode:

Service mode:

1. Use the service remote control unit.
2. Turn the power on.
3. Press the service button on the service remote control unit. The following screen appears.

"*" differs depending on the models.

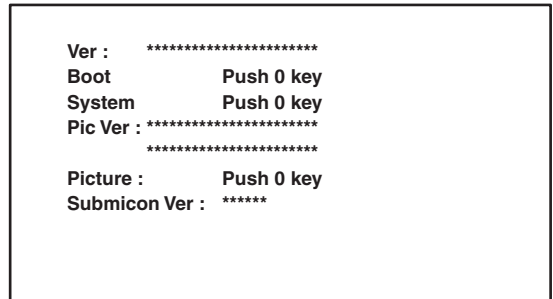

1. Purity Check Mode

This mode cycles through full-screen displays of red, green, blue, and white to check for non-active pixels.

1. Enter the Service mode.
2. Each time pressing [7] button on the service remote control unit, the display changes as follows.

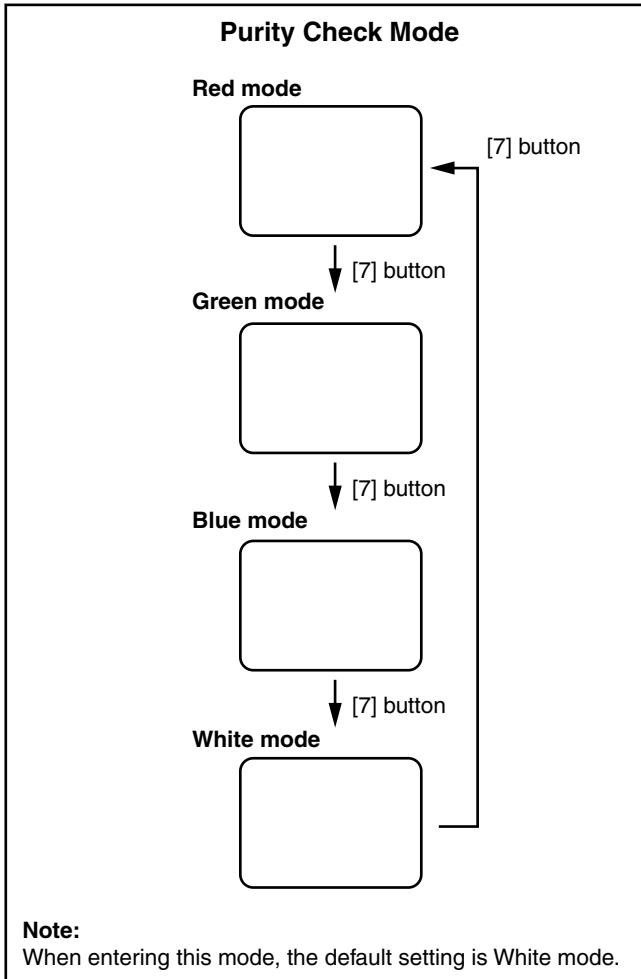

2. VCOM Adjustment

*This adjustment is required when repairing T-CON CBA.

Test Point	Adj. Point
Screen	[CH. ▲/▼] buttons
M. EQ.	Spec.
Color analyzer	See below

Figure

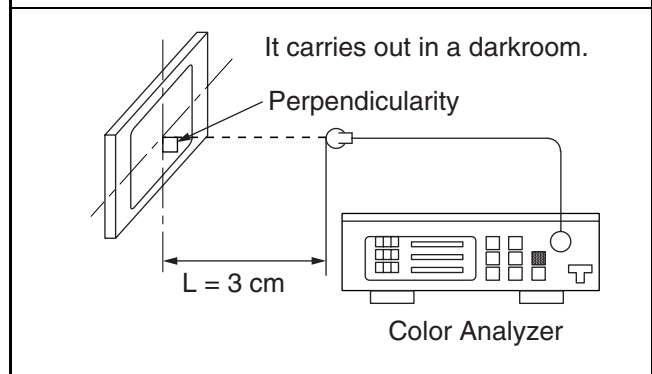

Note: Use the service remote control unit

1. Operate the unit for more than 20 minutes.
2. Set the color analyzer and bring the optical receptor to the center on the LCD-Panel surface after zero point calibration as shown above.
Note: The optical receptor must be set perpendicularly to the LCD Panel surface.
3. Enter the Service mode.
4. Press [3] button on the remote control unit.
5. Press [CH. ▲ / ▼] buttons on the remote control unit so that the color analyzer value becomes minimum.

The following adjustment normally are not attempted in the field. Only when replacing the LCD Panel then adjust as a preparation.

3. White Balance Adjustment

*This adjustment is required when repairing T-CON CBA.

Purpose: To mix red, green and blue beams correctly for pure white.

Symptom of Misadjustment: White becomes bluish or reddish.

Test Point	Adj. Point	Mode	Input
Screen	[CH. ▲/▼] buttons	[RF/VIDEO1, 2] C/D	White Purity (APL 70%) or (APL 25%)
M. EQ.		Spec.	
Pattern Generator, Color analyzer		$x = 0.272 \pm 0.005$ $y = 0.278 \pm 0.005$	

Figure

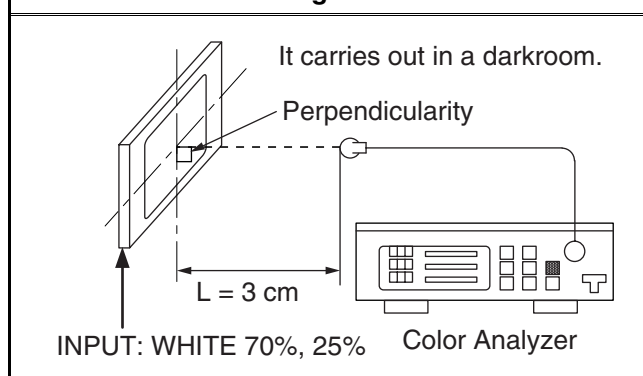

1. Operate the unit for more than 20 minutes.
2. Input the White Purity.

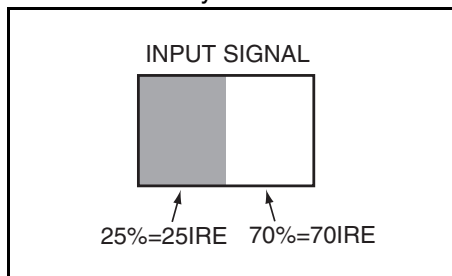

3. Set the color analyzer to the CHROMA mode and bring the optical receptor to the center on the LCD-Panel surface after zero point calibration as shown above.

Note: The optical receptor must be set perpendicularly to the LCD Panel surface.

4. Enter the Service mode. Press [VOL. ▼] button on the remote control unit and select "C/D" mode.

5. **[CUTOFF]**
Press [3] button to select "COB" for Blue Cutoff adjustment. Press [1] button to select "COR" for Red Cutoff adjustment.

[DRIVE]

Press [6] button to select "DB" for Blue Drive adjustment. Press [4] button to select "DR" for Red Drive adjustment.

6. In each color mode, press [CH. ▲ / ▼] buttons to adjust the values of color.
7. Adjust Cutoff and Drive so that the color temperature becomes 12000K ($x = 0.272 / y = 0.278 \pm 0.005$).

HOW TO INITIALIZE THE LCD TV/DVD

To put the program back at the factory-default, initialize the LCD TV/DVD using the following procedure.

< DVD Section >

1. Press [1], [2], [3], [4], and [INFO] buttons on the remote control unit in that order.
Fig. g appears on the screen.

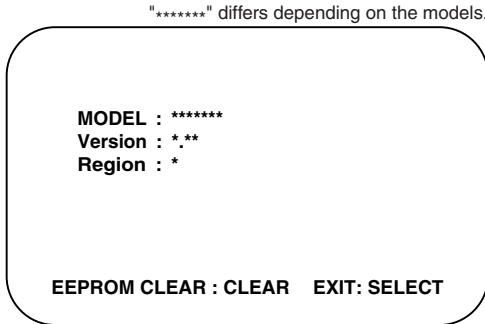

Fig. g

2. Press [CLEAR] button on the remote control unit.
Fig. h appears on the screen.

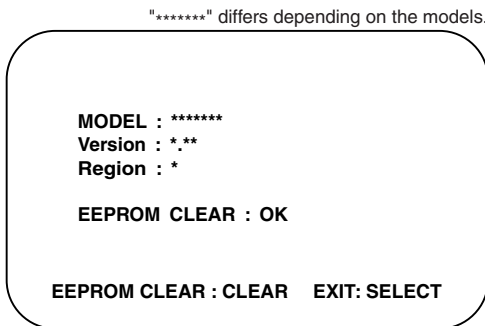

Fig. h

When "OK" appears on the screen, the factory default will be set.

3. To exit this mode, press [CH. ▲ / ▼] button to go to TV mode, or press [POWER] button to turn the power off.

< LCD TV Section >

1. Turn the power on.
2. To enter the service mode, press the service button on the service remote control unit. (Refer to page 6-1.)
 - To cancel the service mode, press [POWER] button on the remote control unit.
3. Press [INFO] button on the remote control unit to initialize the LCD television.
4. "INITIALIZED" will appear in the upper right of the screen. "INITIALIZED" color will change to green from red when initializing is complete.

FIRMWARE RENEWAL MODE

1. Turn the power on and press [EJECT] button on the remote control unit to put the LCD TV/DVD into DVD mode. Then remove the disc.
2. To put the LCD TV/DVD into F/W version up mode, press [9], [8], [7], [6], and [SEARCH MODE] buttons on the remote control unit in that order. Fig. a appears on the screen.

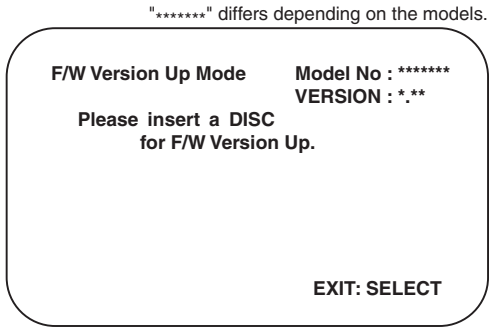

Fig. a Version Up Mode Screen

3. Insert the disc for version up into the disc slot.
4. The LCD TV/DVD enters the F/W version up mode automatically. Fig. c appears on the screen. If you enter the F/W for different models, "Disc Error" will appear on the screen, then the disc will be ejected automatically.

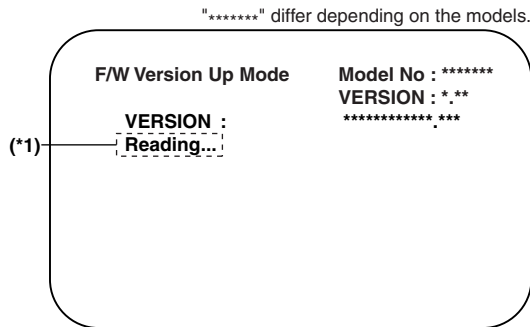

Fig. c Programming Mode Screen

The appearance shown in (*1) of Fig. c is described as follows:

No.	Appearance	State
1	Reading...	Sending files into the memory
2	Erasing...	Erasing previous version data
3	Programming...	Writing new version data

5. After programming is finished, the disc will be ejected automatically. Fig. e appears on the screen and the checksum will be shown in (*2).

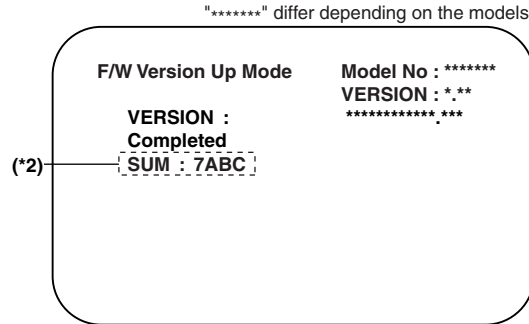

Fig. e Completed Program Mode Screen

At this time, no button is available.

6. Remove the disc.
7. Unplug the AC cord from the AC outlet. Then plug it again.
8. Press [EJECT] button on the remote control unit to put the LCD TV/DVD into DVD mode again.
9. Press [1], [2], [3], [4], and [INFO] buttons on the remote control unit in that order. Fig. g appears on the screen.

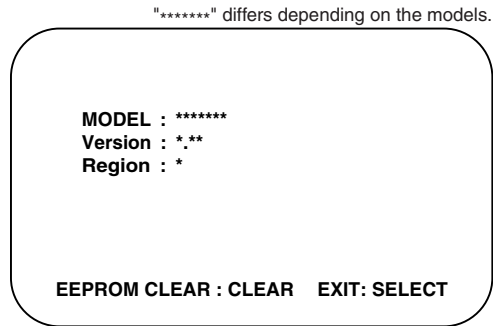

Fig. g

10. Press [CLEAR] button on the remote control unit. Fig. h appears on the screen.

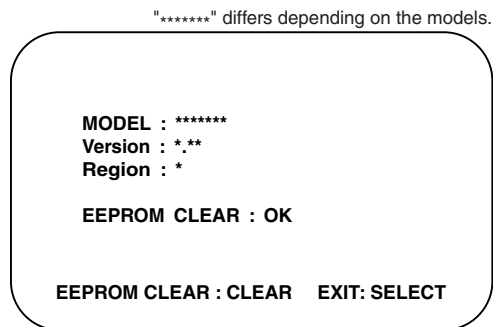

Fig. h

When "OK" appears on the screen, the factory default will be set. Then the firmware renewal mode is complete.

11. To exit this mode, press [CH. ▲ / ▼] button to go to TV mode, or press [POWER] button to turn the power off.

BLOCK DIAGRAMS < LCD TV Section >

System Control Block Diagram

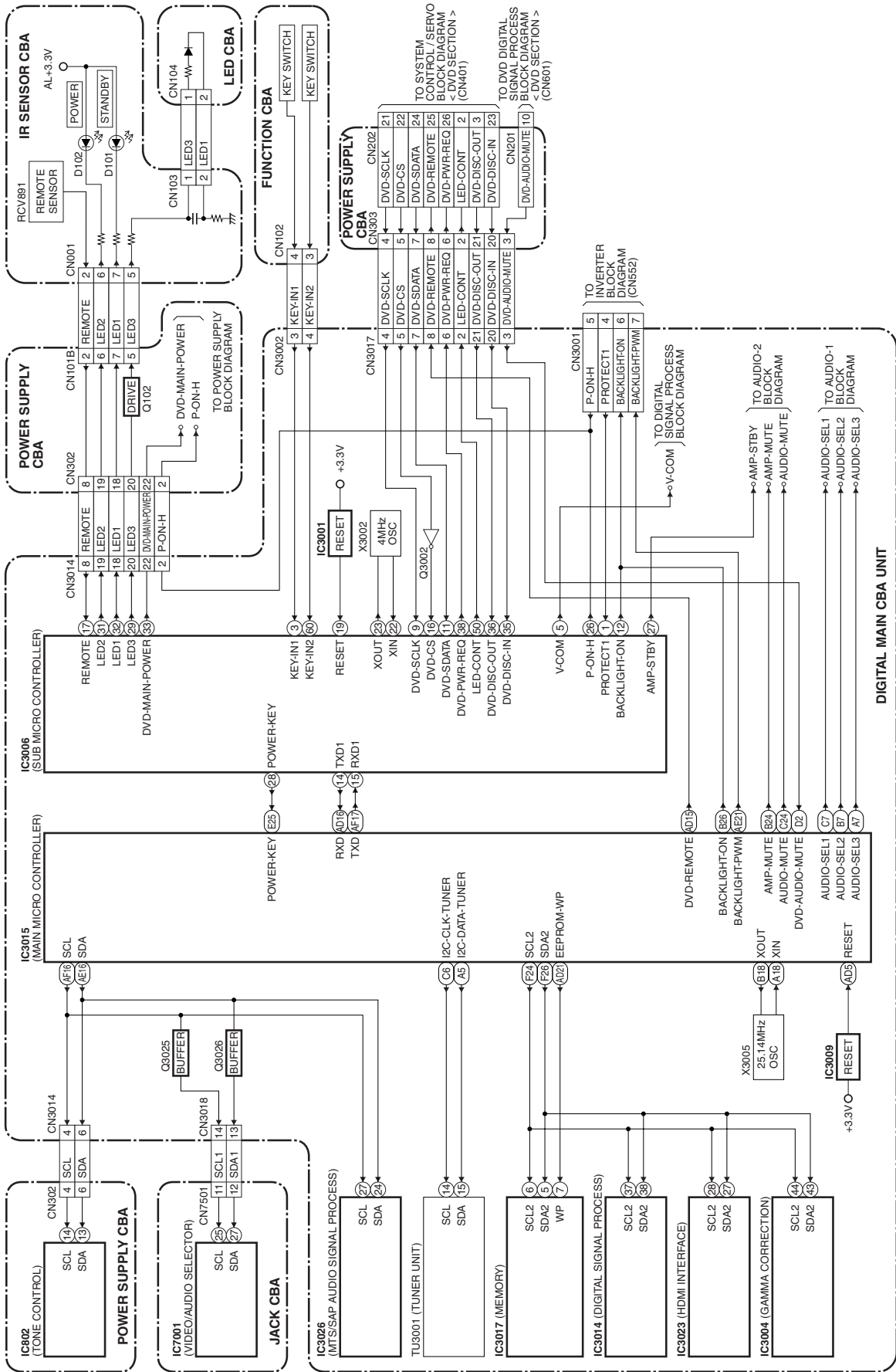

Video Block Diagram

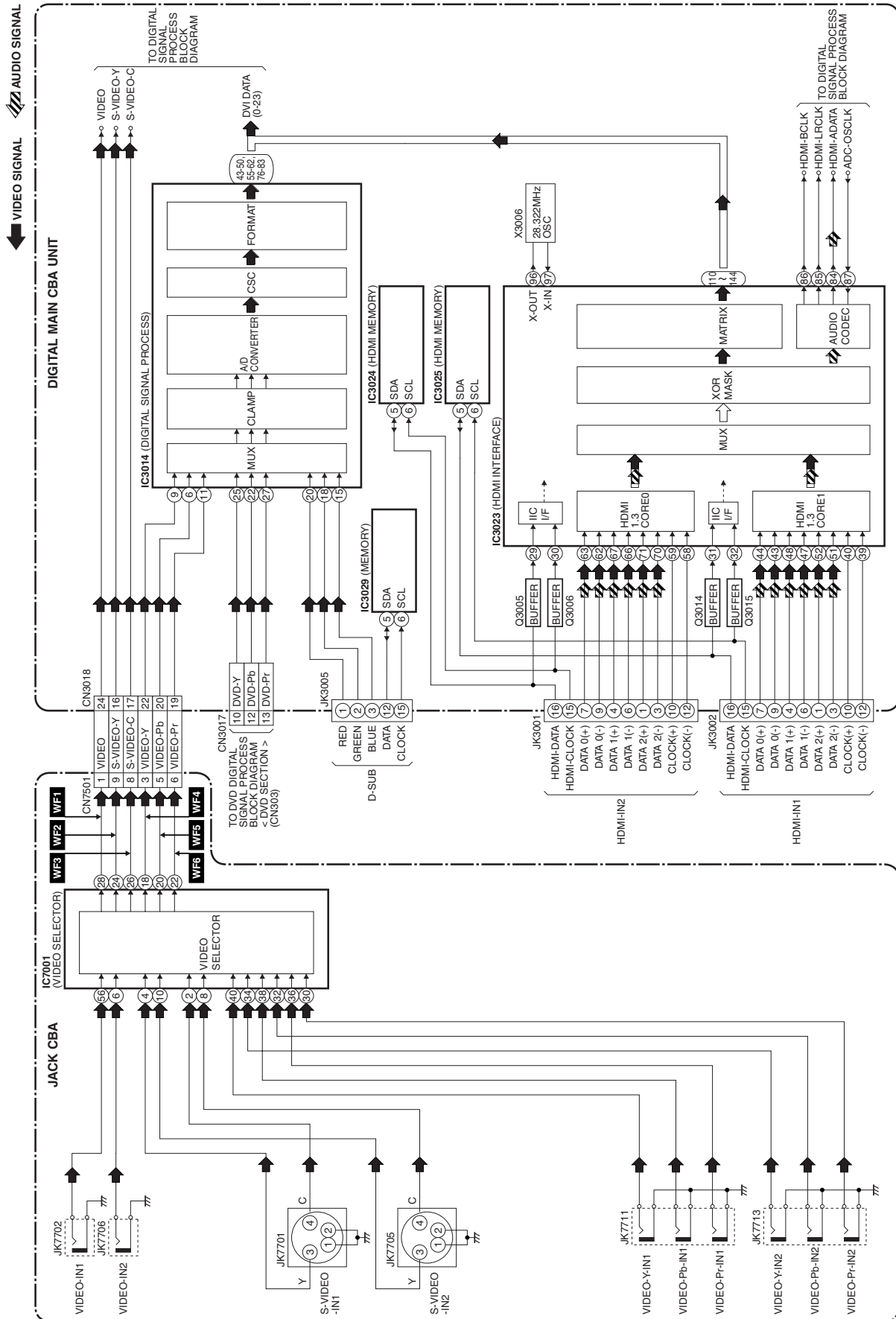

Audio-1 Block Diagram

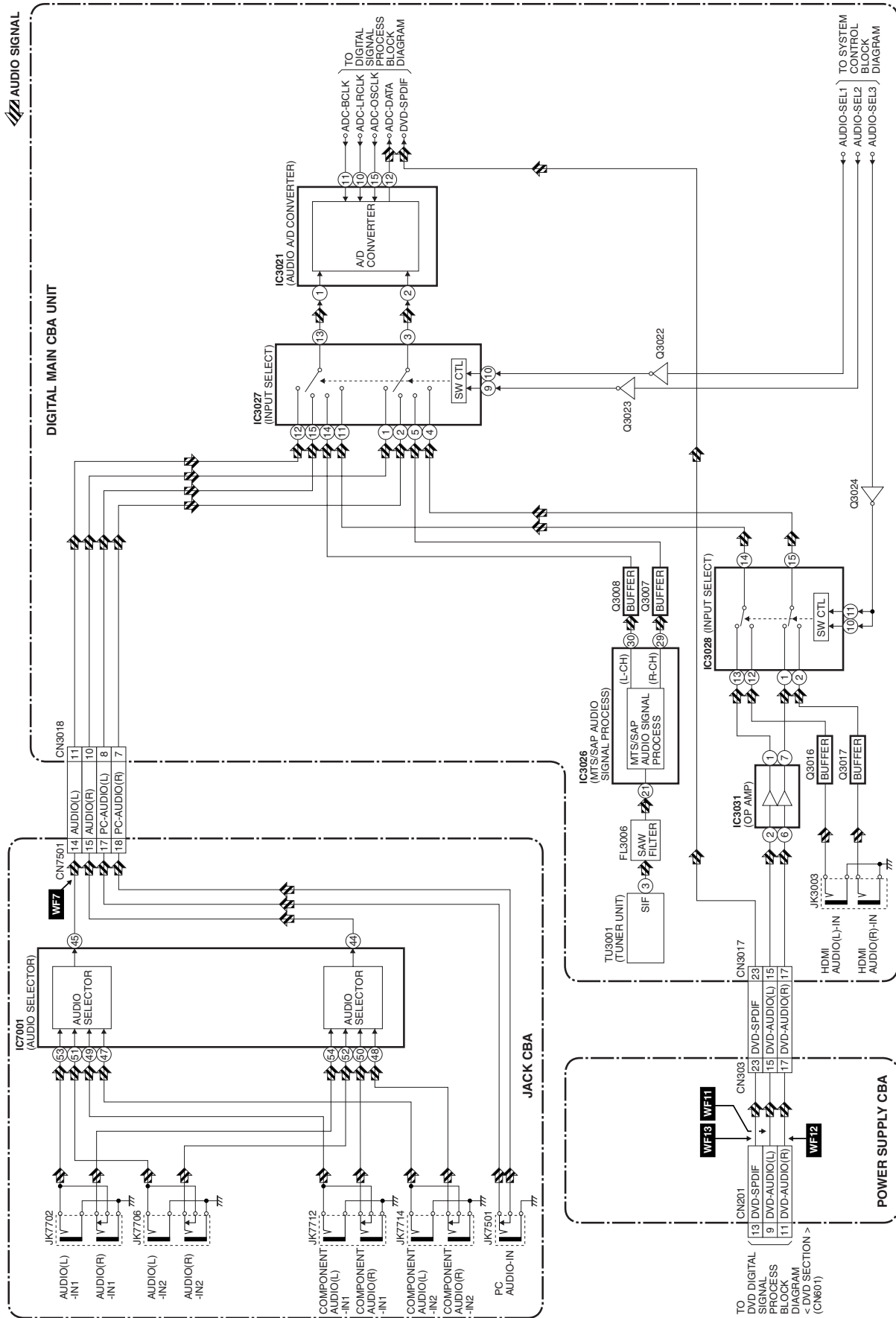

Audio-2 Block Diagram

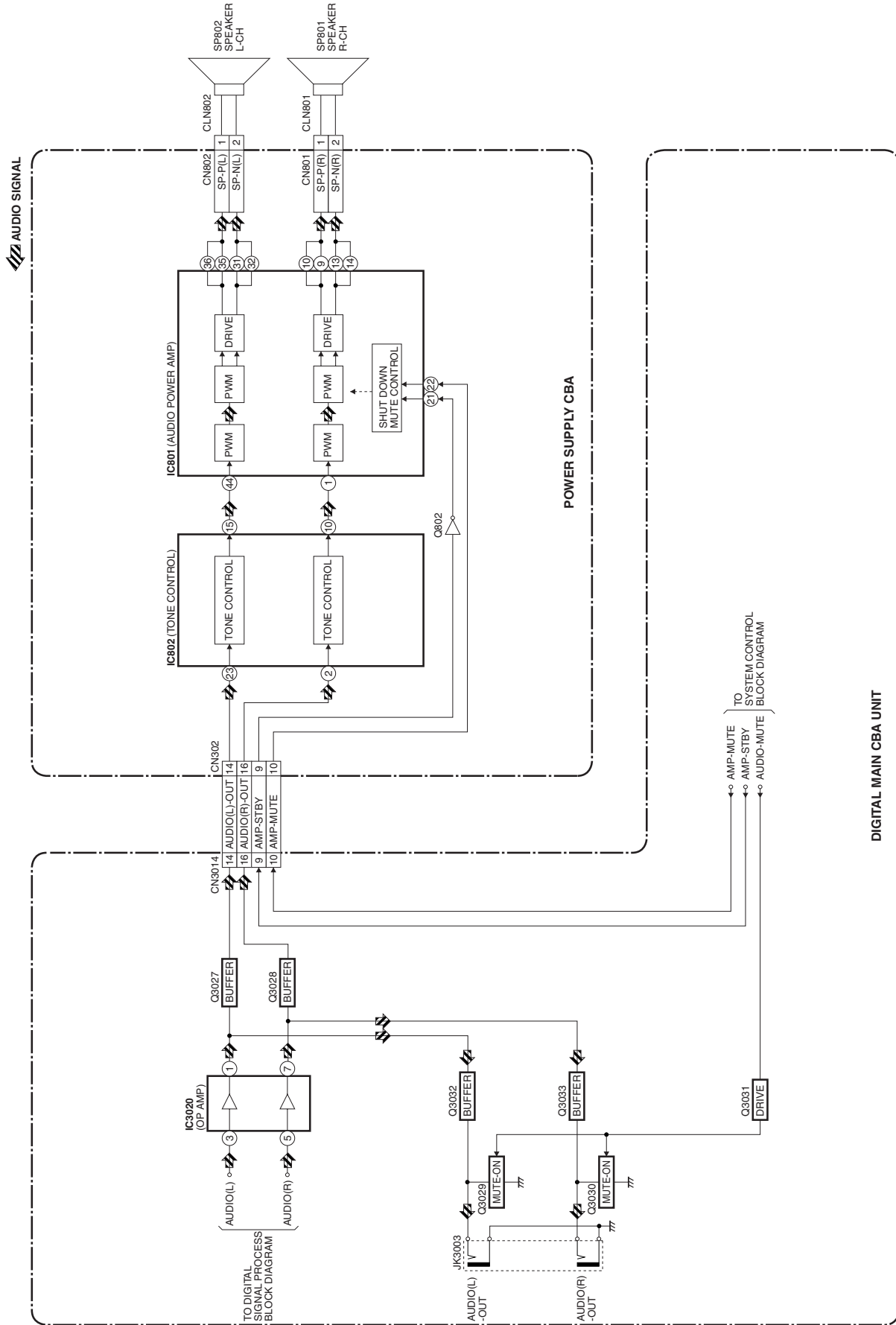

Digital Signal Process Block Diagram

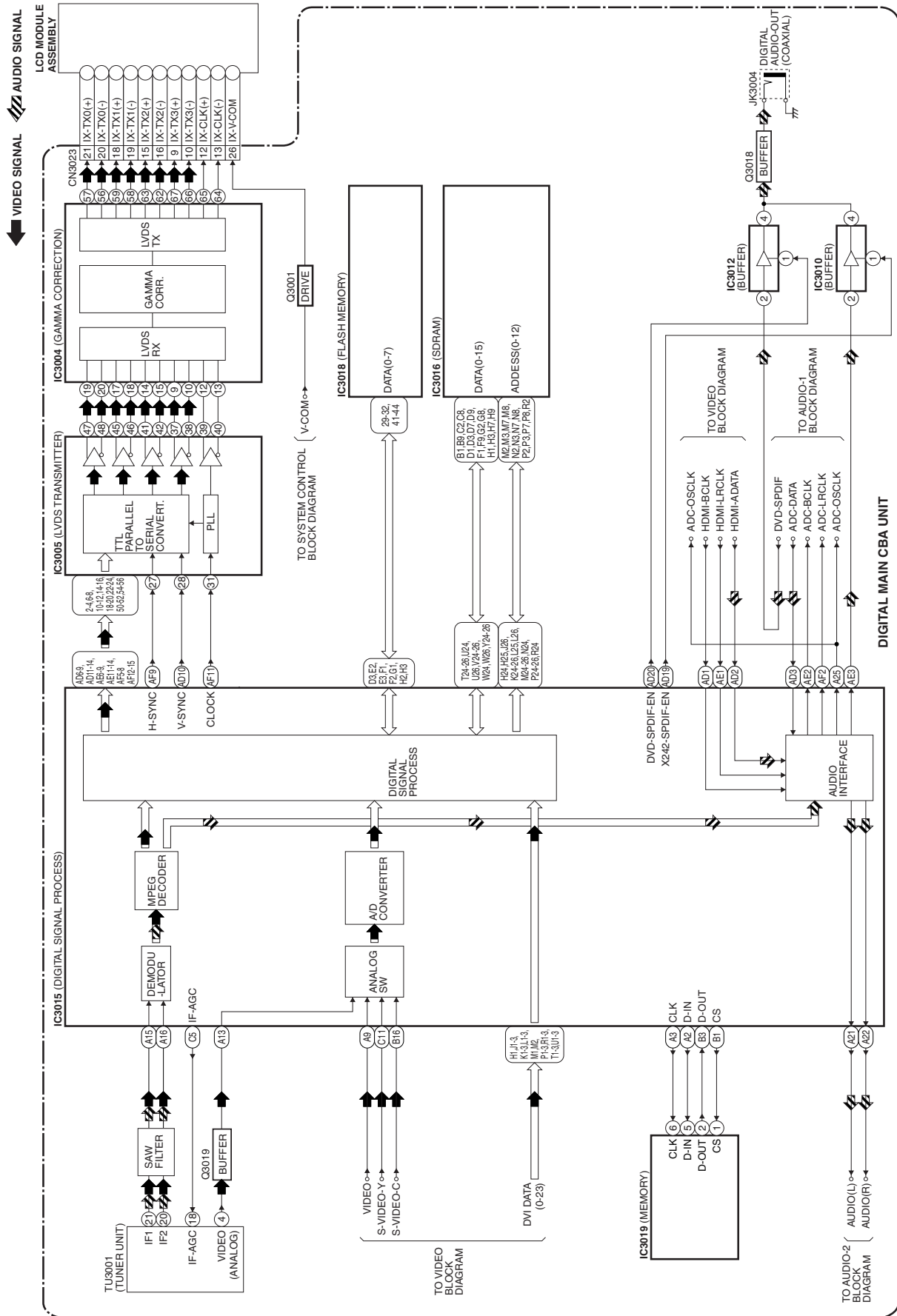

Inverter Block Diagram

NOTE:
The voltage for parts in hot circuit is measured using hot GND as a common terminal.

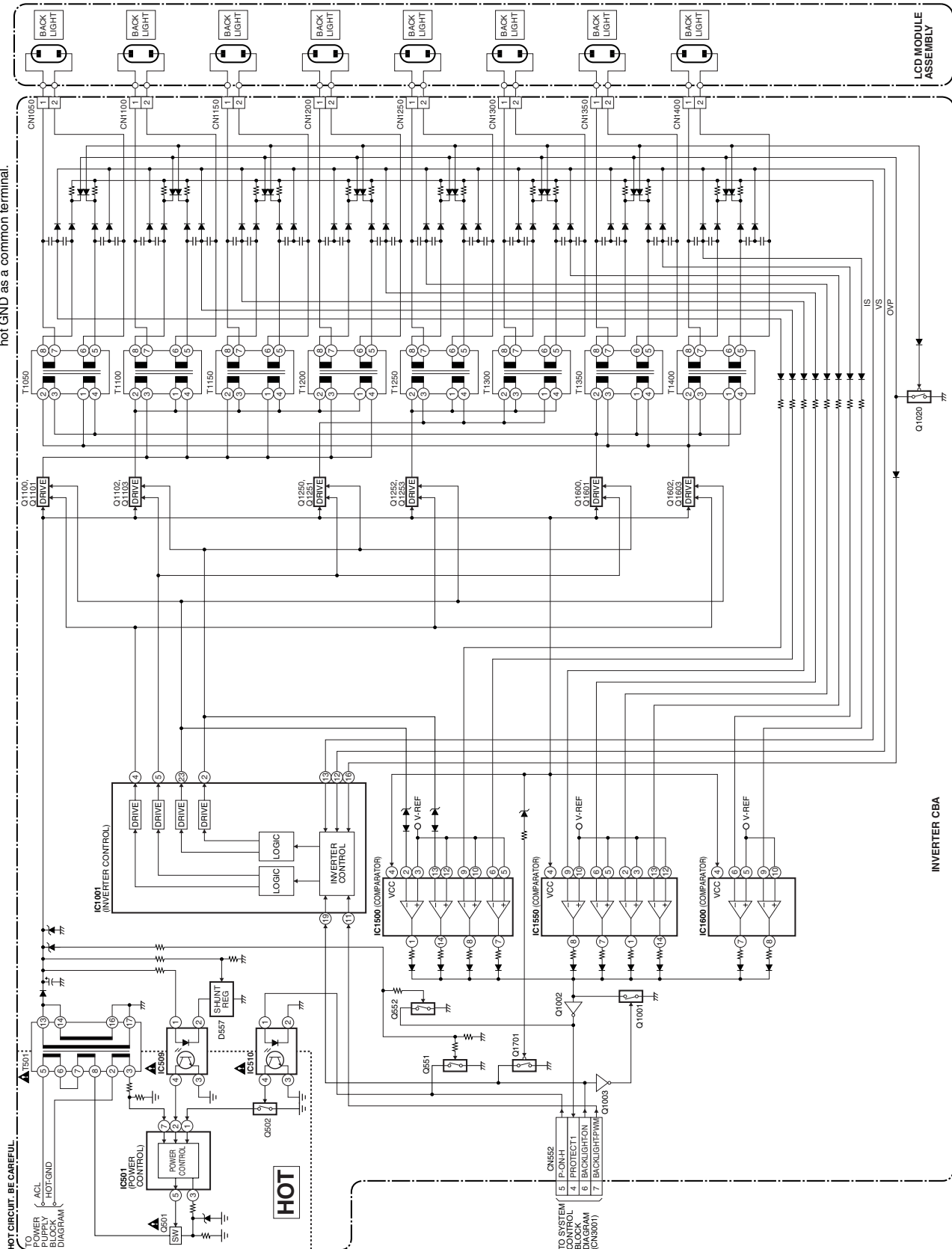

Power Supply Block Diagram

CAUTION !

Fixed voltage (or Auto voltage selectable) power supply circuit is used in this unit. If Main Fuse (F501) is blown, check to see that all components in the power supply circuit are not defective before you connect the AC plug to the AC power supply. Otherwise it may cause some components in the power supply circuit to fail.



CAUTION ! : For continued protection against risk of fire, replace only with same type 4 A, 125V fuse.
ATTENTION : Utiliser un fusible de même type de 4A, 125V.

NOTE:

The voltage for parts in hot circuit is measured using hot GND as a common terminal.

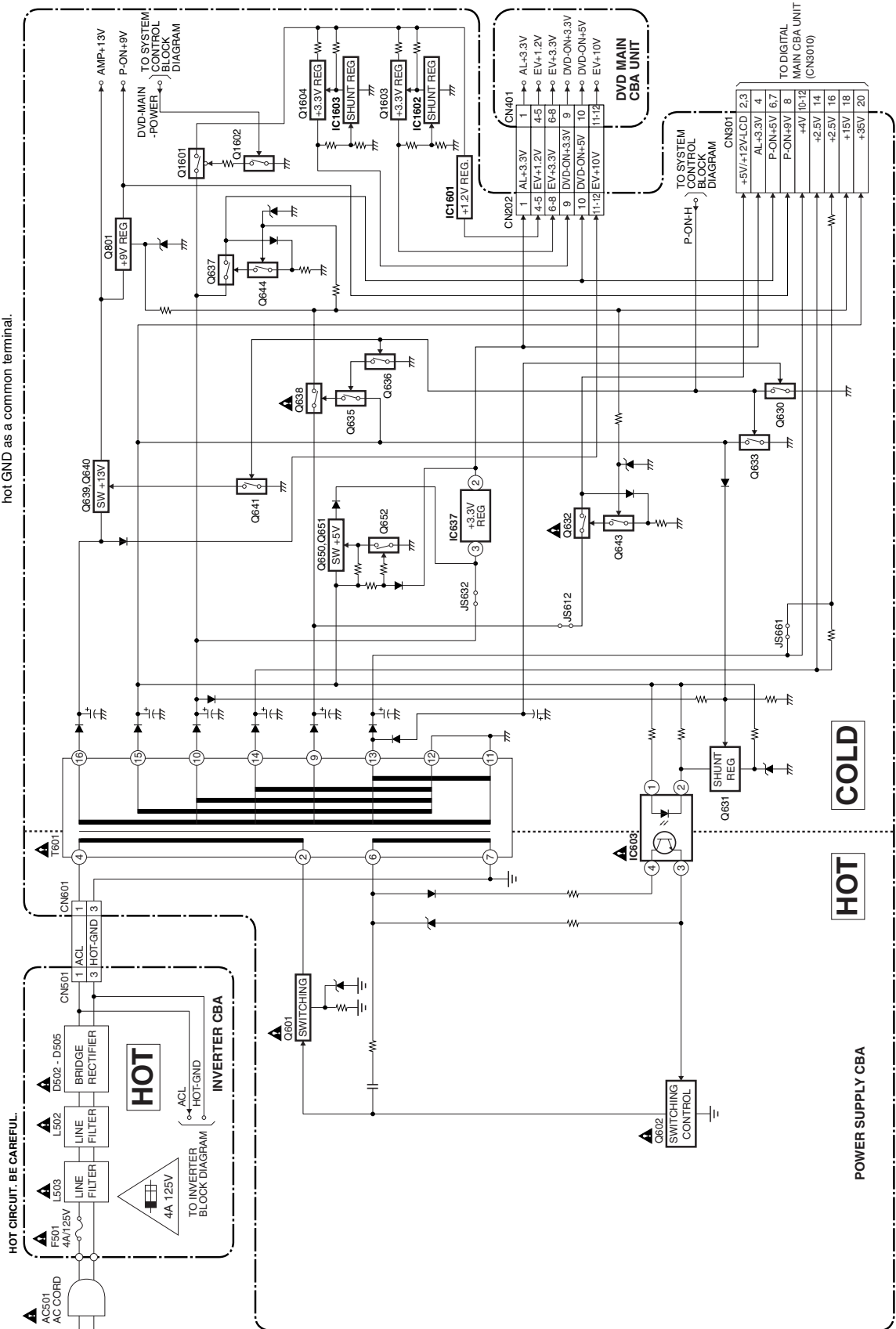

BLOCK DIAGRAMS < DVD Section >

System Control / Servo Block Diagram

*1 NOTE:
Either IC461 or IC462 is used for DVD MAIN CBA UNIT.

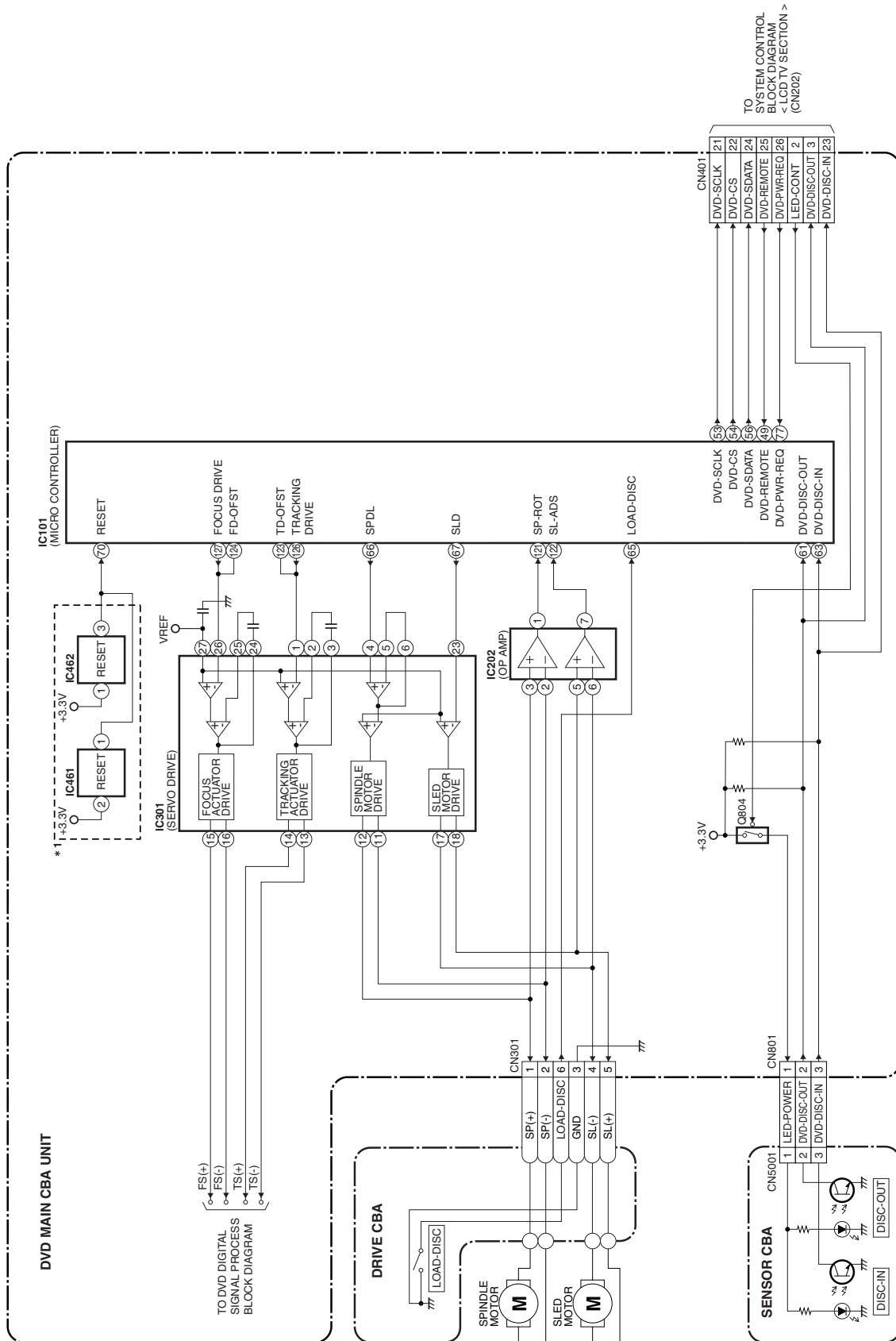

TO
SYSTEM CONTROL
BLOCK DIAGRAM
< LCD TV SECTION >
(CN202)

DVD Digital Signal Process Block Diagram

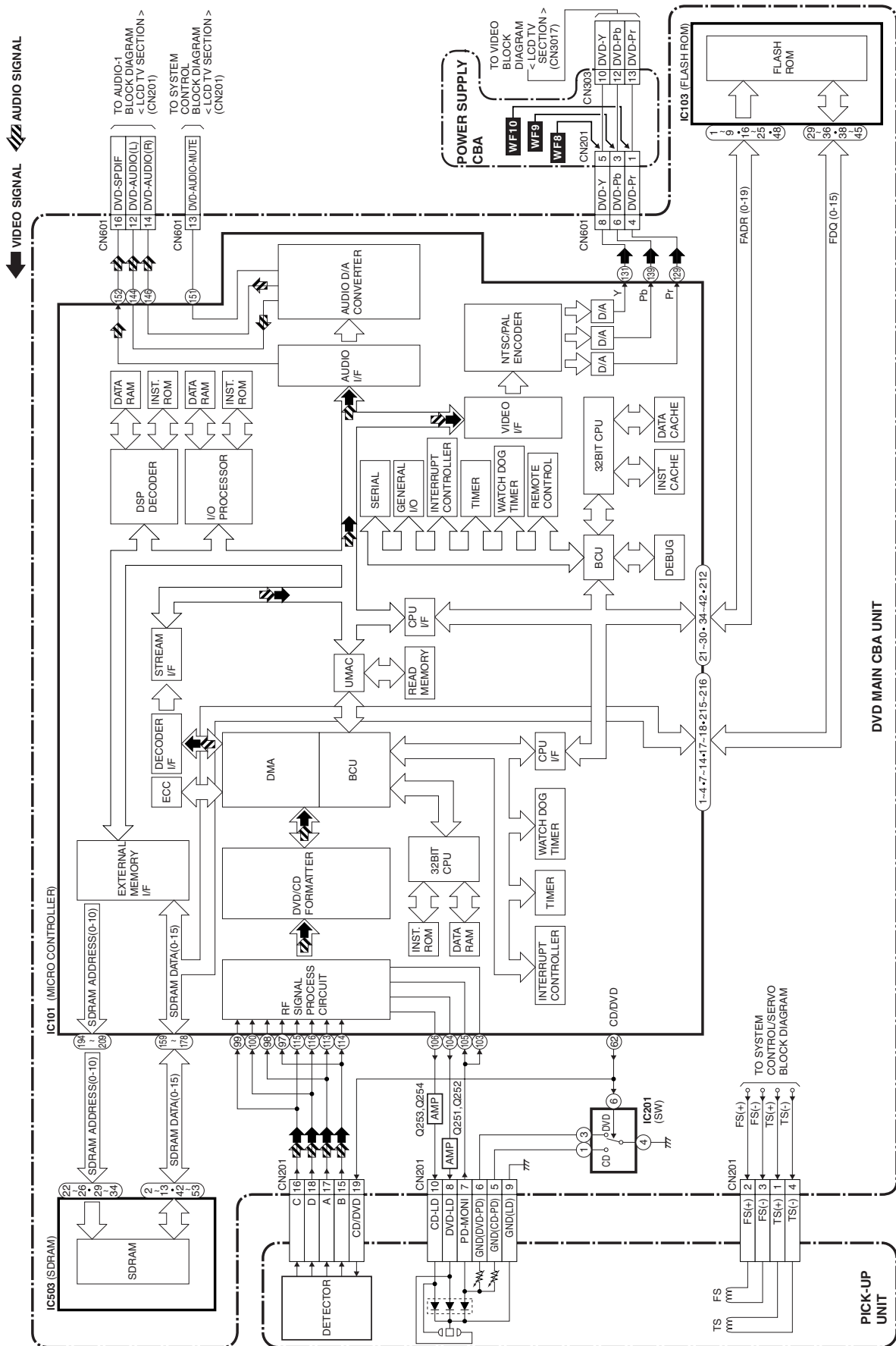

SCHEMATIC DIAGRAMS / CBA'S AND TEST POINTS

Standard Notes

WARNING

Many electrical and mechanical parts in this chassis have special characteristics. These characteristics often pass unnoticed and the protection afforded by them cannot necessarily be obtained by using replacement components rated for higher voltage, wattage, etc. Replacement parts that have these special safety characteristics are identified in this manual and its supplements; electrical components having such features are identified by the mark "▲" in the schematic diagram and the parts list. Before replacing any of these components, read the parts list in this manual carefully. The use of substitute replacement parts that do not have the same safety characteristics as specified in the parts list may create shock, fire, or other hazards.

Notes:

1. Do not use the part number shown on these drawings for ordering. The correct part number is shown in the parts list, and may be slightly different or amended since these drawings were prepared.
2. All resistance values are indicated in ohms (K = 10^3 , M = 10^6).
3. Resistor wattages are 1/4W or 1/6W unless otherwise specified.
4. All capacitance values are indicated in μF (P = 10^{-6} μF).
5. All voltages are DC voltages unless otherwise specified.

LIST OF CAUTION, NOTES, AND SYMBOLS USED IN THE SCHEMATIC DIAGRAMS ON THE FOLLOWING PAGES:

1. CAUTION:

CAUTION: FOR CONTINUED PROTECTION AGAINST RISK OF FIRE, REPLACE ONLY WITH SAME TYPE_A,_V FUSE.

ATTENTION: UTILISER UN FUSIBLE DE RECHANGE DE MÊME TYPE DE_A,_V.

2. CAUTION:

Fixed Voltage (or Auto voltage selectable) power supply circuit is used in this unit.

If Main Fuse (F501) is blown, first check to see that all components in the power supply circuit are not defective before you connect the AC plug to the AC power supply. Otherwise it may cause some components in the power supply circuit to fail.

3. Note:

- Do not use the part number shown on the drawings for ordering. The correct part number is shown in the parts list, and may be slightly different or amended since the drawings were prepared.
- To maintain original function and reliability of repaired units, use only original replacement parts which are listed with their part numbers in the parts list section of the service manual.

4. Voltage indications for PLAY and STOP modes on the schematics are as shown below:

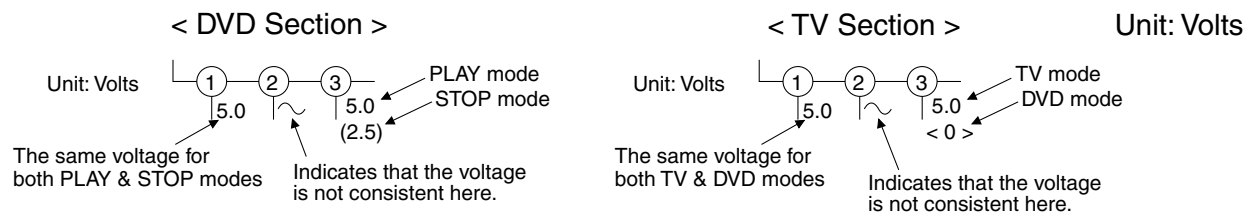

5. How to read converged lines

1-D3
 ↑ Distinction Area
 ↑ Line Number
 (1 to 3 digits)

Examples:

- "1-D3" means that line number "1" goes to the line number "1" of the area "D3".
- "1-B1" means that line number "1" goes to the line number "1" of the area "B1".

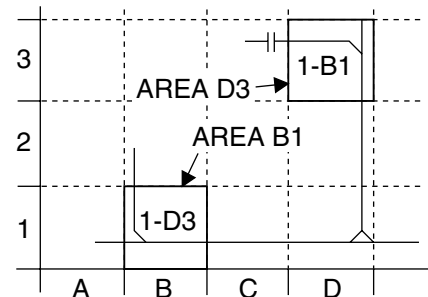

6. Test Point Information

- ⊕ : Indicates a test point with a jumper wire across a hole in the PCB.
- : Used to indicate a test point with a component lead on foil side.
- ⊗ : Used to indicate a test point with no test pin.
- : Used to indicate a test point with a test pin.

Power Supply 1/3 Schematic Diagram < LCD TV Section >

NOTE:
The voltage for parts in hot circuit is measured using hot GND as a common terminal.

VOLTAGE CHART
CN301

Pin No.	Voltage
1	0
2	12.3
3	12.3
4	3.4
5	0
6	5.1
7	5.1
8	9.2
9	0
10	5.2
11	5.2
12	5.2
13	0
14	3.3
15	0
16	2.8
17	0
18	15.7
19	0
20	33.1
21	0
22	3.0
23	1.3

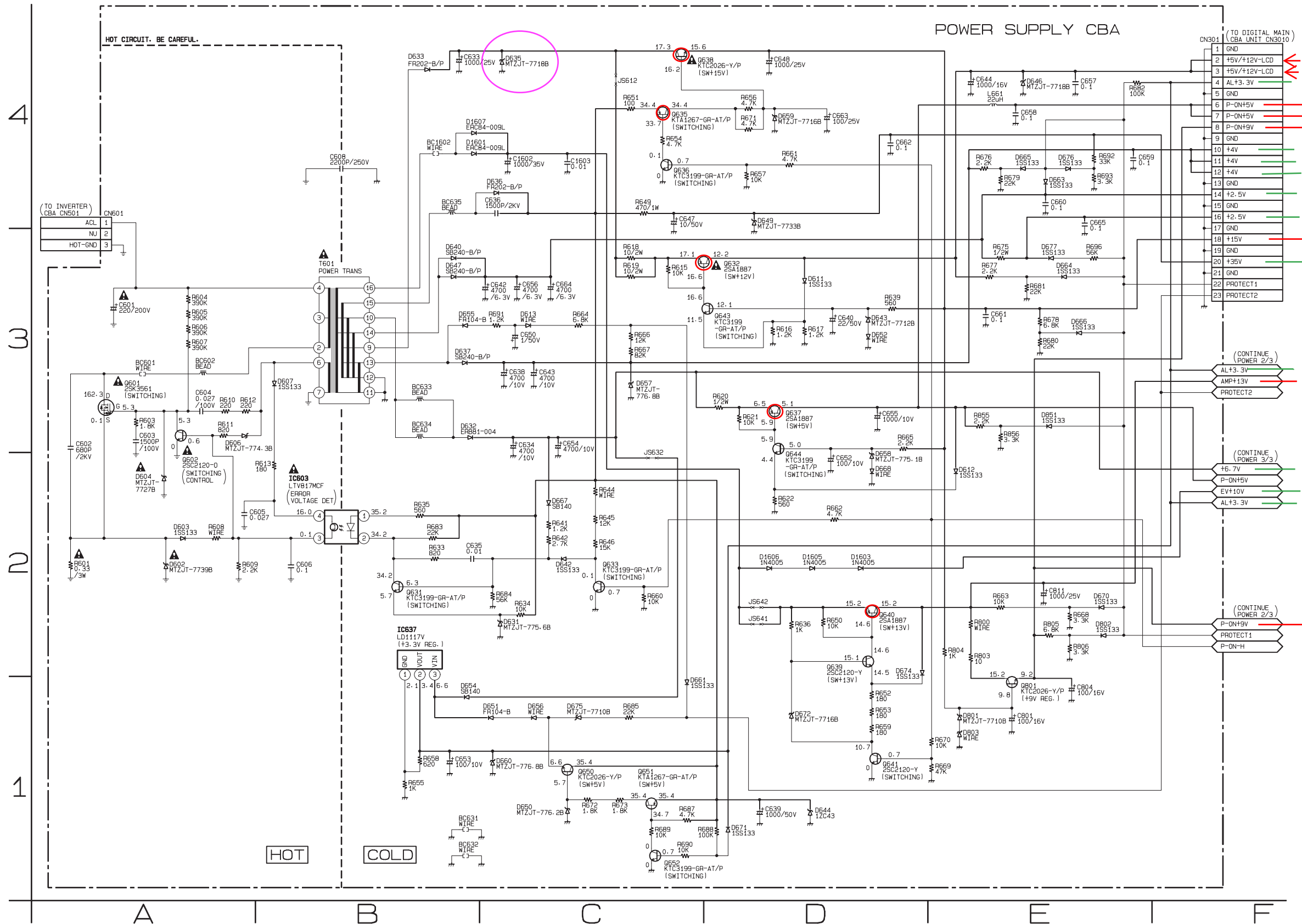

Power Supply 2/3 Schematic Diagram < LCD TV Section >

NOTE:
The voltage for parts in hot circuit is measured using hot GND as a common terminal.

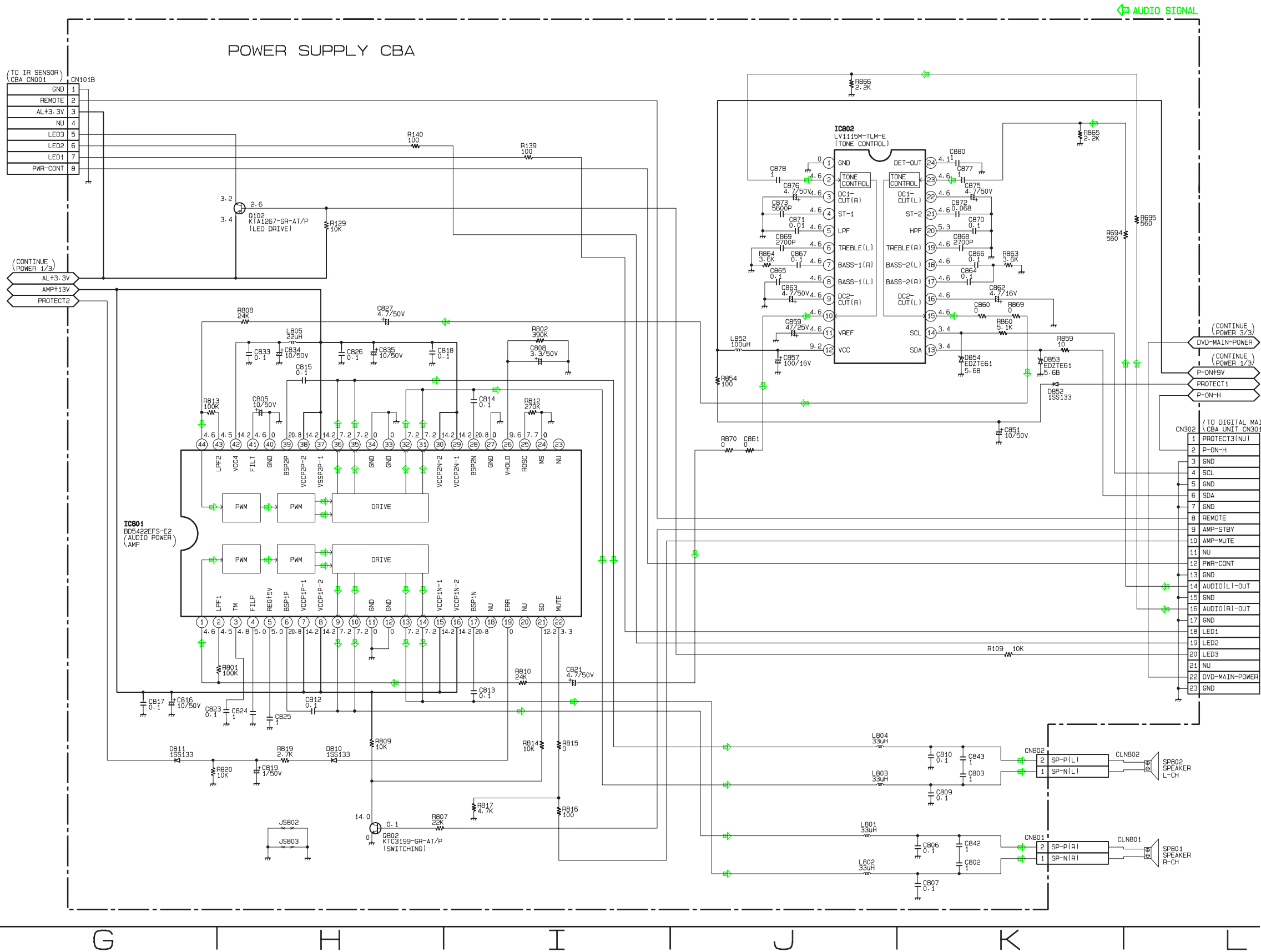

VOLTAGE CHART

Pin No.	Voltage
1	---
2	3.1
3	0
4	3.4
5	0
6	3.4
7	0
8	3.4
9	0.1
10	3.3
11	---
12	3.4
13	0
14	6.3
15	0
16	6.3
17	0
18	3.3
19	0.9
20	0.2
21	---
22	0
23	0

Power Supply 3/3 Schematic Diagram < LCD TV Section >

NOTE:
The voltage for parts in hot circuit is measured using hot GND as a common terminal.

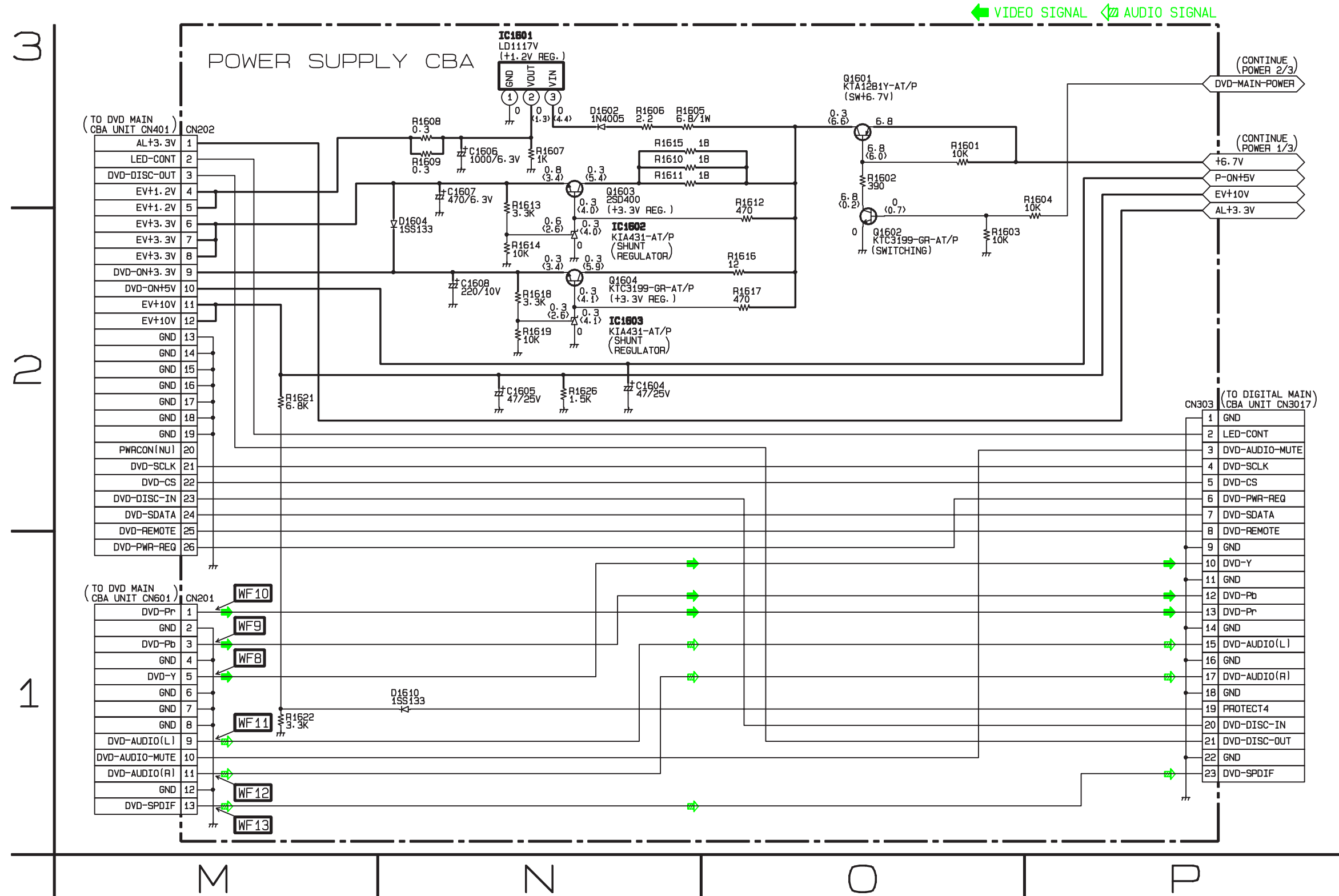

VOLTAGE CHART

Pin No.	Voltage
1	0
2	3.0
3	0
4	0.3
5	0.2
6	3.2
7	0.3
8	0
9	0
10	0
11	0
12	0
13	0
14	0
15	0
16	0
17	0
18	0
19	3.4
20	2.6
21	2.6
22	0
23	0

Inverter Schematic Diagram < LCD TV Section >

CAUTION !

Fixed voltage (or Auto voltage selectable) power supply circuit is used in this unit.
If Main Fuse (F501) is blown, check to see that all components in the power supply circuit are not defective before you connect the AC plug to the AC power supply.
Otherwise it may cause some components in the power supply circuit to fail.

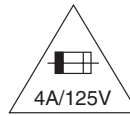

CAUTION ! : For continued protection against risk of fire, replace only with same type 4 A, 125V fuse.
ATTENTION : Utiliser un fusible de rechange de même type de 4A, 125V.

NOTE:

The voltage for parts in hot circuit is measured using hot GND as a common terminal.

VOLTAGE CHART

Pin No.	Voltage
1	0
2	3.3
3	0.1
4	3.2
5	3.0
6	3.3
7	3.4
8	0

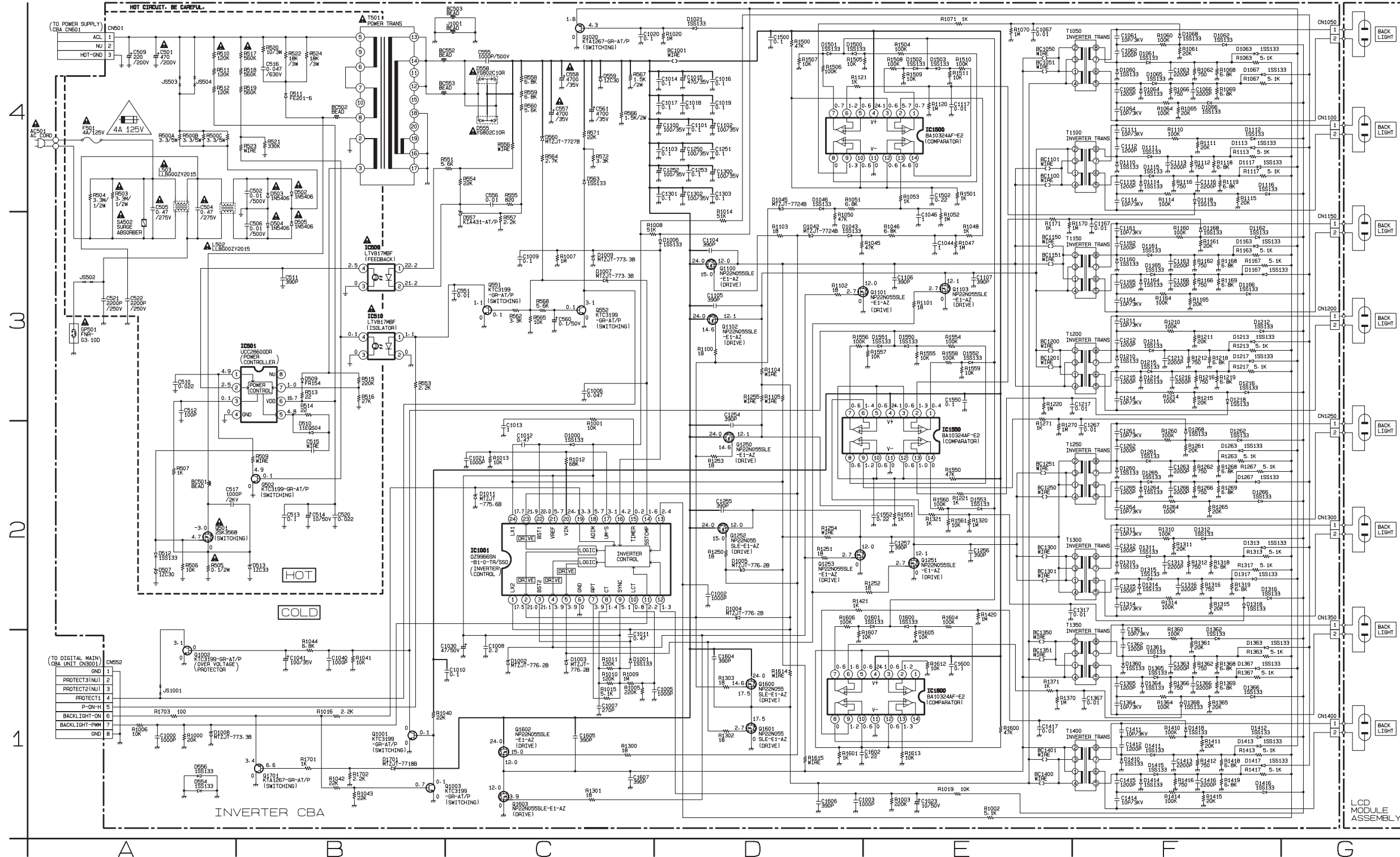

Jack Schematic Diagram < LCD TV Section >

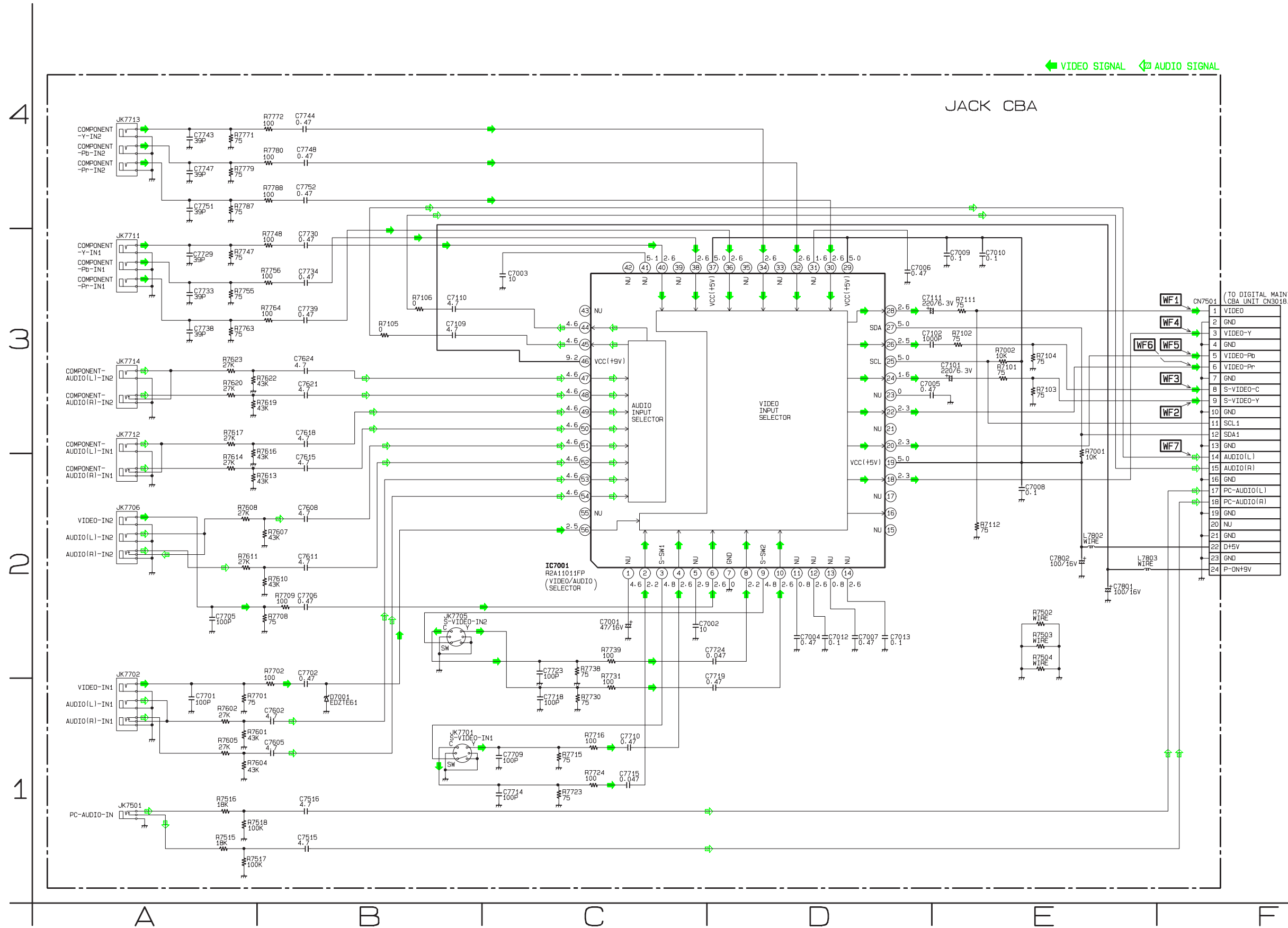

VOLTAGE CHART

CN7501

Pin No.	Voltage
1	2.6
2	0
3	2.3
4	0
5	2.3
6	0
7	0
8	0
9	0
10	0
11	5.0
12	5.0
13	0
14	2.5
15	2.5
16	0
17	2.5
18	2.5
19	0
20	---
21	0
22	5.0
23	0
24	9.1

Function Schematic Diagram < LCD TV Section >

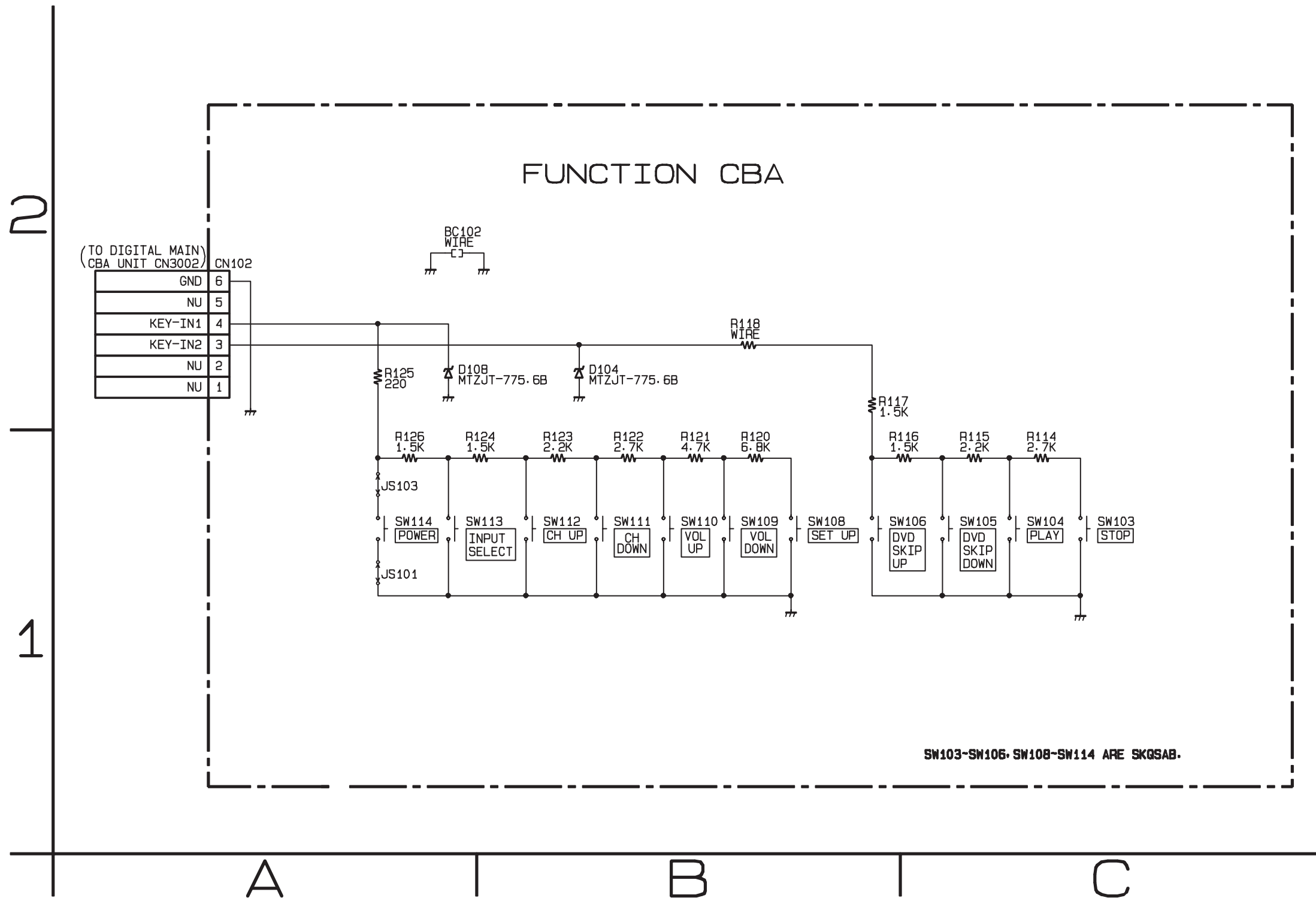

VOLTAGE CHART

CN102	
Pin No.	Voltage
1	---
2	---
3	3.4
4	3.4
5	---
6	0

IR Sensor & LED Schematic Diagram < LCD TV Section >

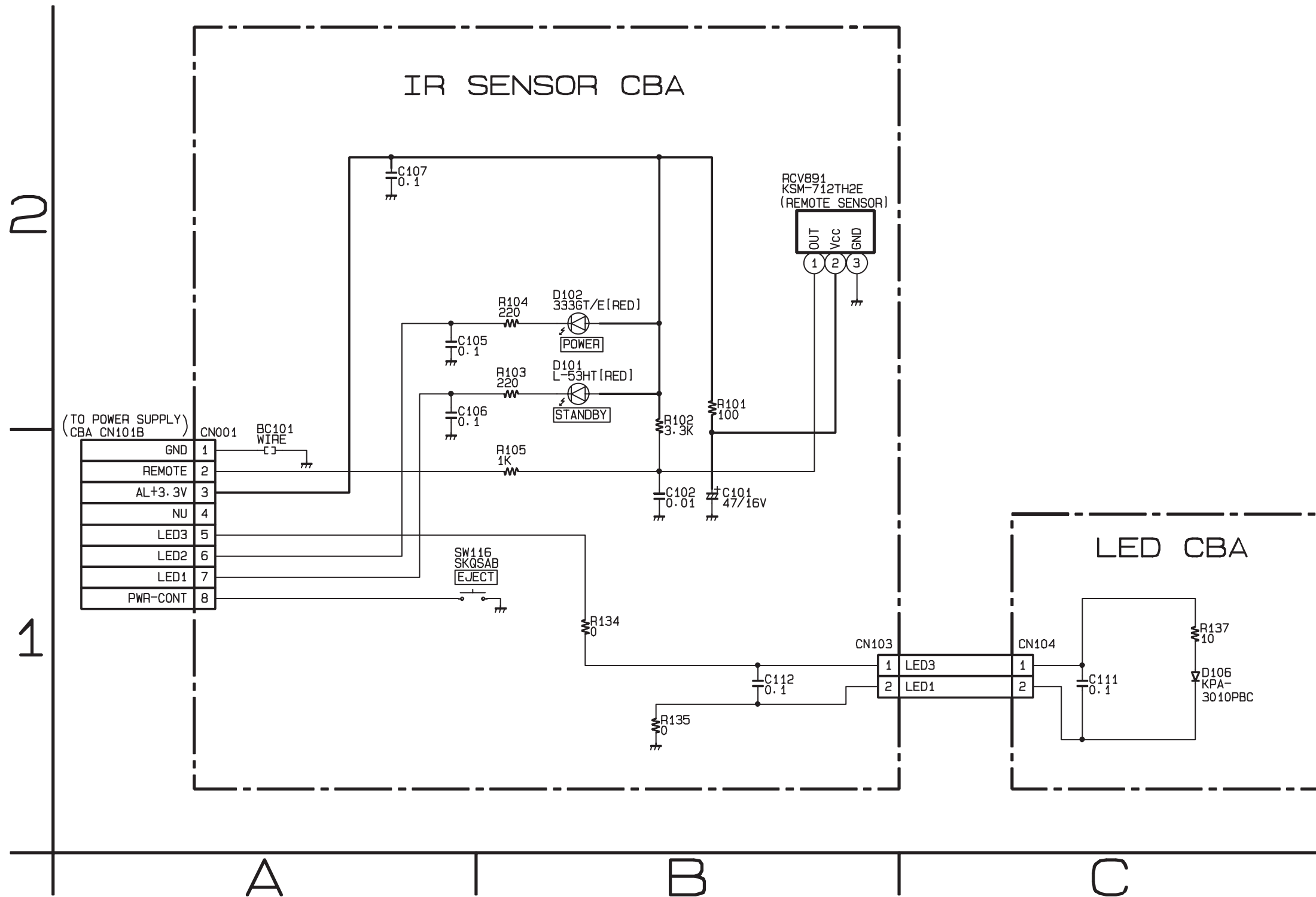

Digital Main 1/10 Schematic Diagram < LCD TV Section >

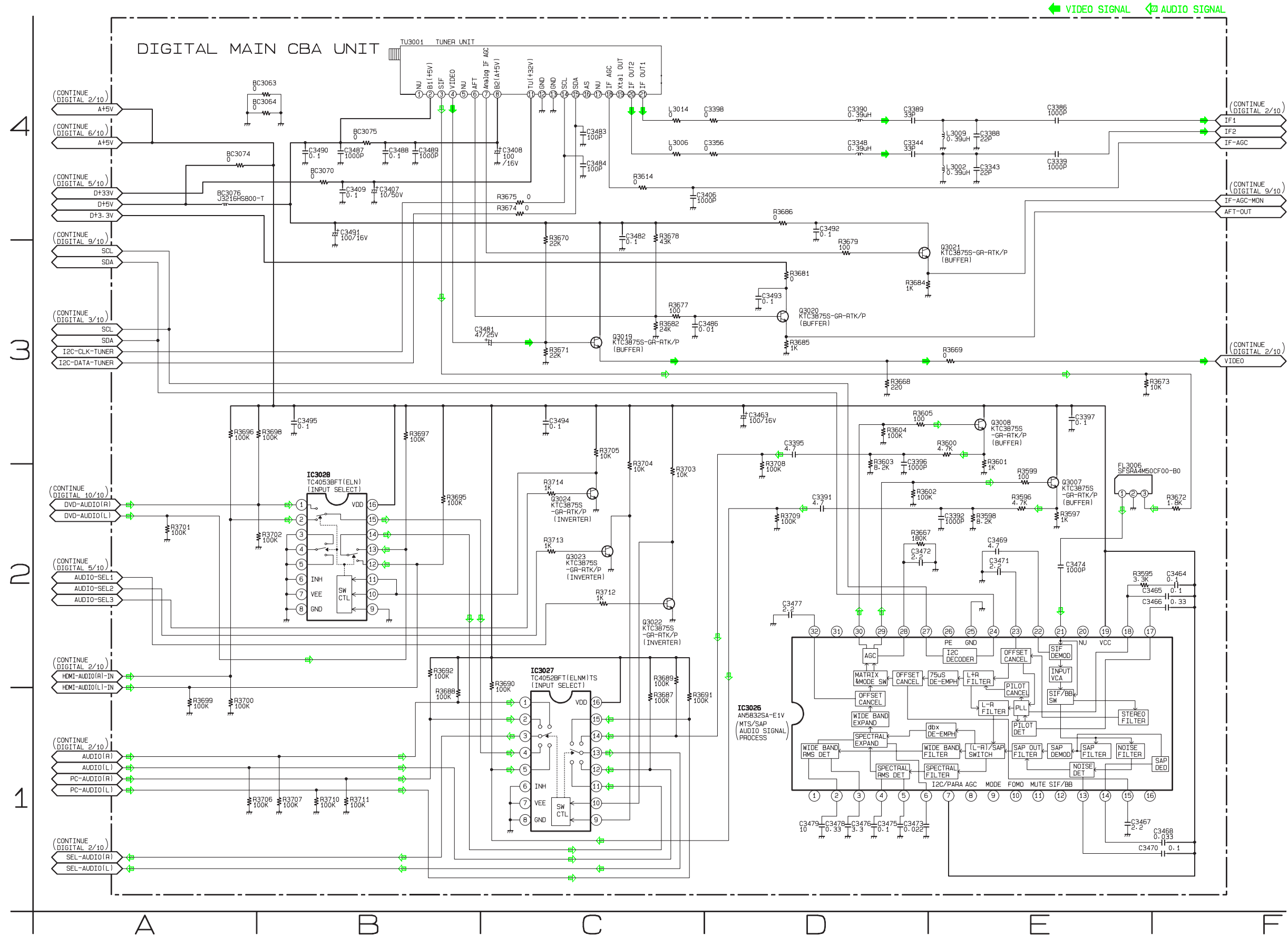

Digital Main 2/10 Schematic Diagram < LCD TV Section >

***1 NOTE:**
 The order of pins shown in this diagram is different from that of actual IC3015.
 IC3015 is divided into four and shown as IC3015 (1/4) ~ IC3015 (4/4) in this Digital Main Schematic Diagram Section.

← VIDEO SIGNAL ← AUDIO SIGNAL

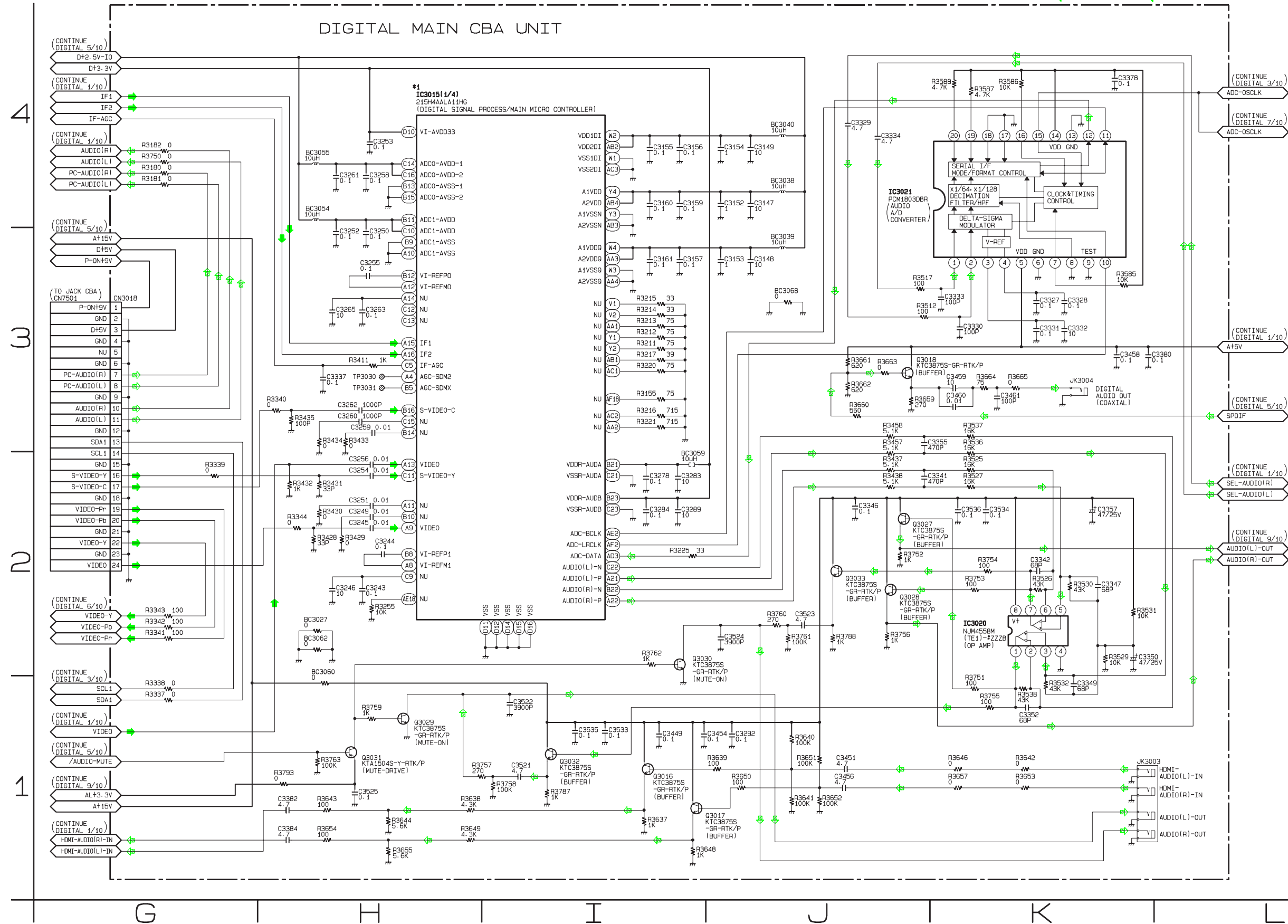

Digital Main 3/10 Schematic Diagram < LCD TV Section >

*1 NOTE:

The order of pins shown in this diagram is different from that of actual IC3015.
 IC3015 is divided into four and shown as IC3015 (1/4) ~ IC3015 (4/4) in this Digital Main Schematic Diagram Section.

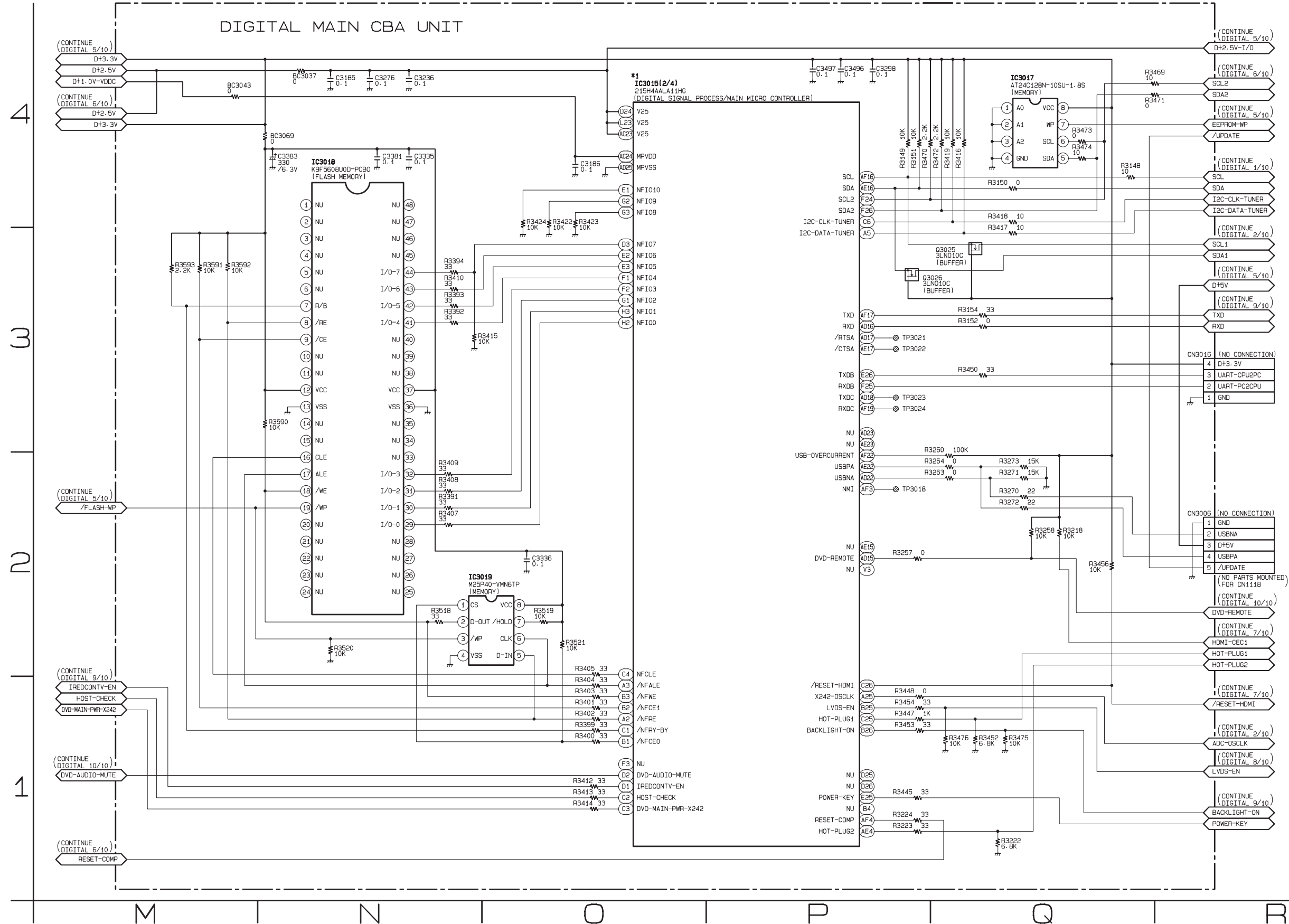

Digital Main 4/10 Schematic Diagram < LCD TV Section >

*1 NOTE:

The order of pins shown in this diagram is different from that of actual IC3015.
IC3015 is divided into four and shown as IC3015 (1/4) ~ IC3015 (4/4) in this Digital Main Schematic Diagram Section.

← VIDEO SIGNAL ← AUDIO SIGNAL

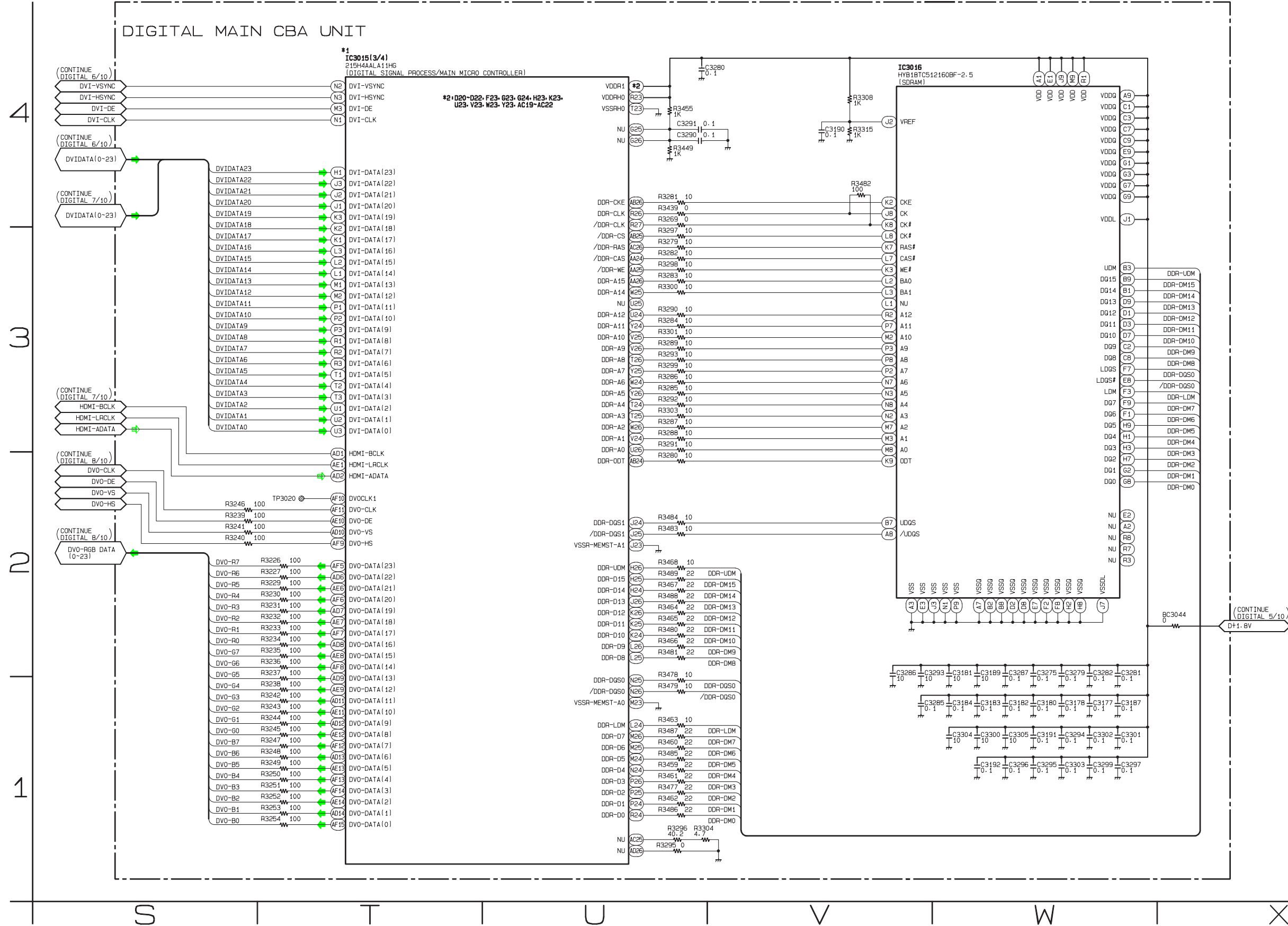

Digital Main 5/10 Schematic Diagram < LCD TV Section >

*1 NOTE:

The order of pins shown in this diagram is different from that of actual IC3015.
 IC3015 is divided into four and shown as IC3015 (1/4) ~ IC3015 (4/4) in this Digital Main Schematic Diagram Section.

← AUDIO SIGNAL

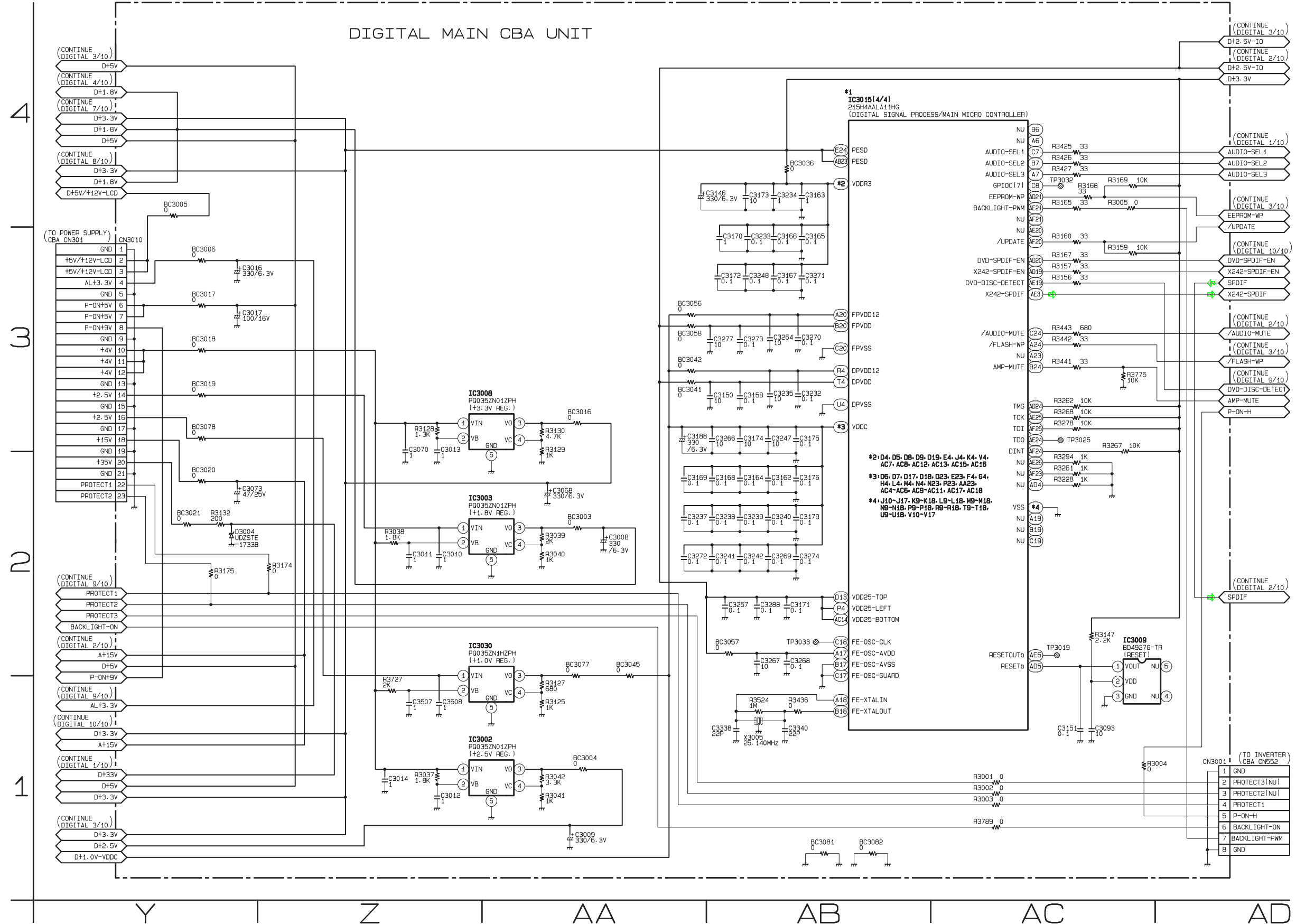

Digital Main 6/10 Schematic Diagram < LCD TV Section >

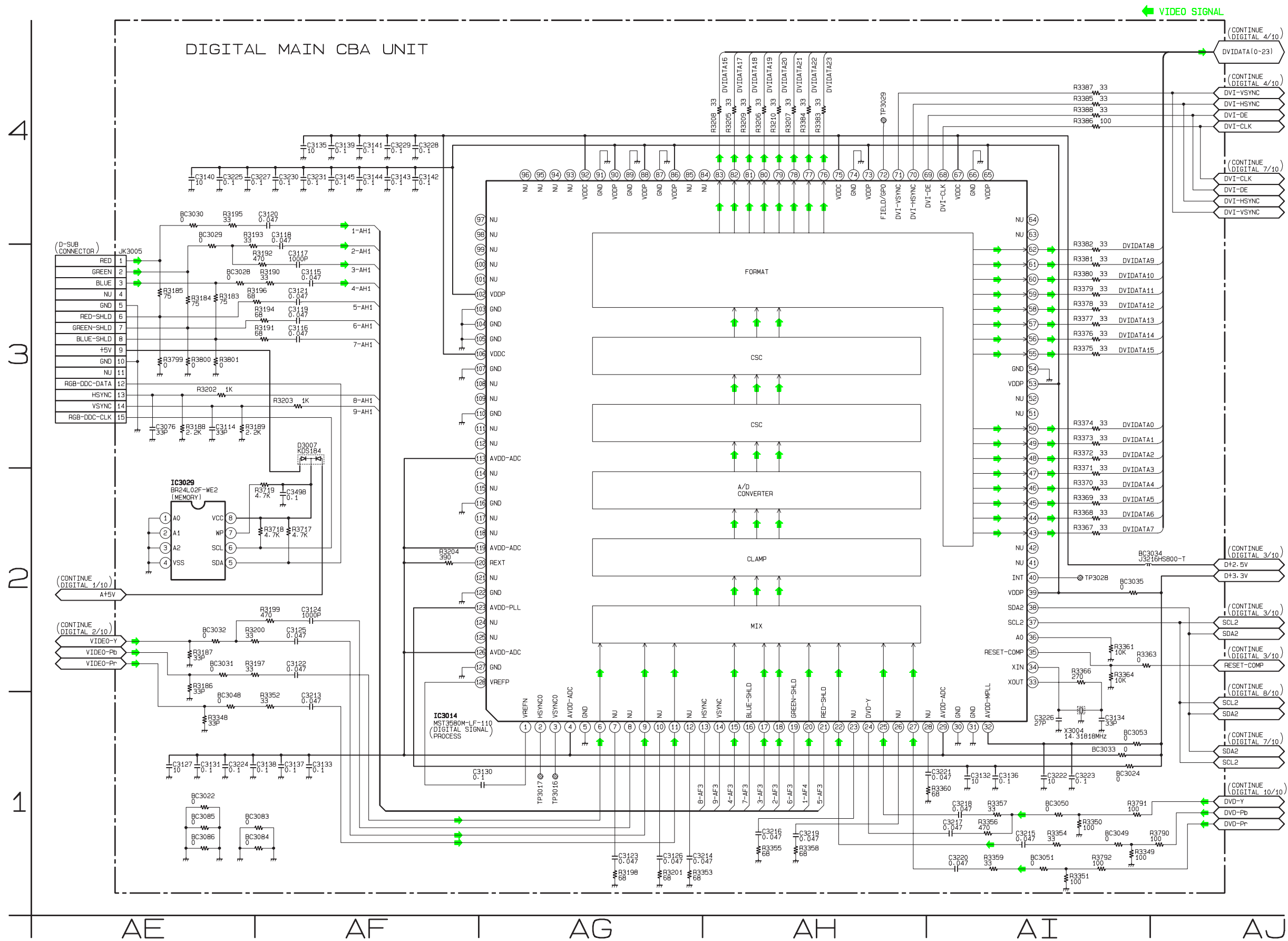

Digital Main 7/10 Schematic Diagram < LCD TV Section >

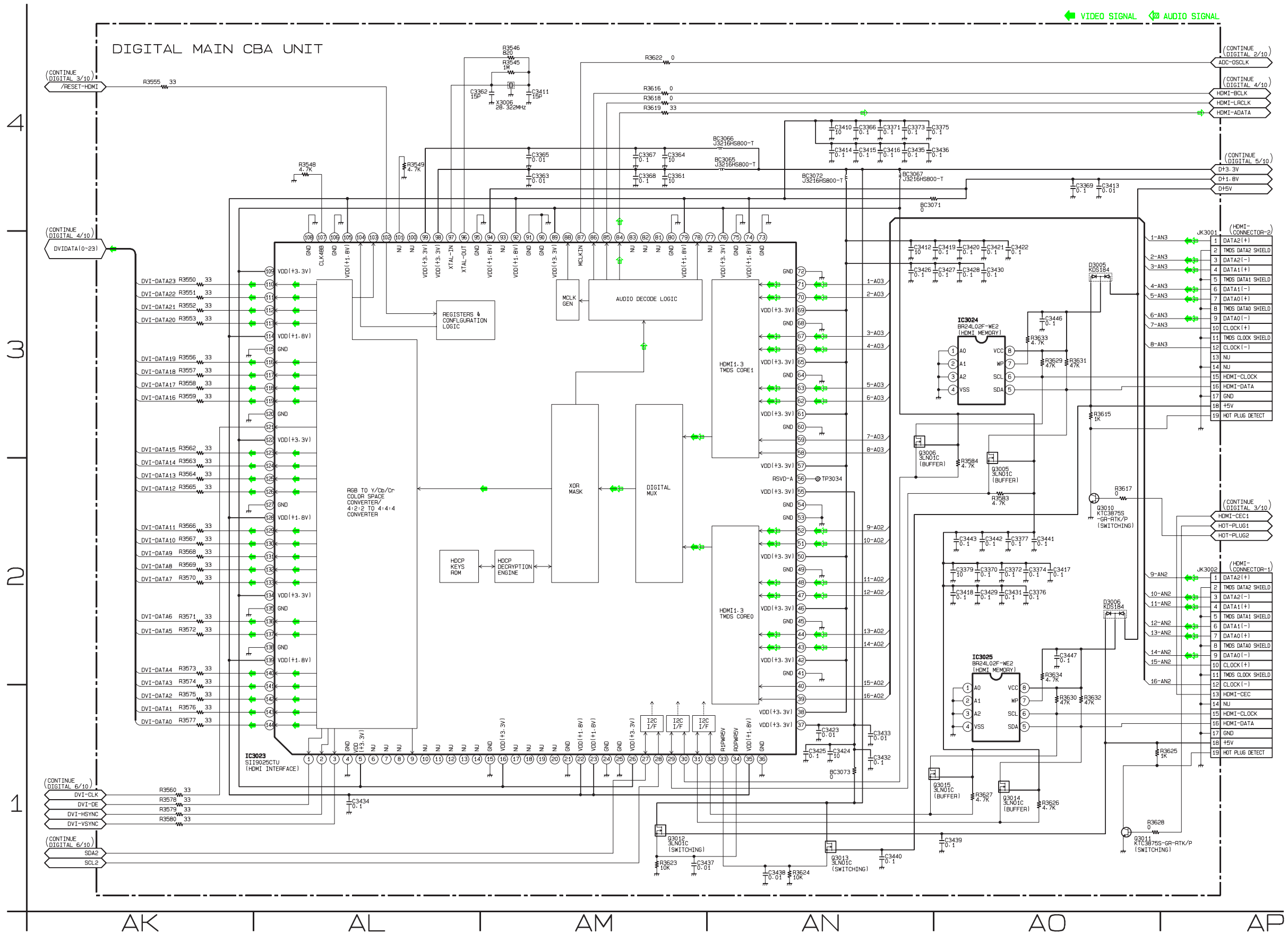

Digital Main 8/10 Schematic Diagram < LCD TV Section >

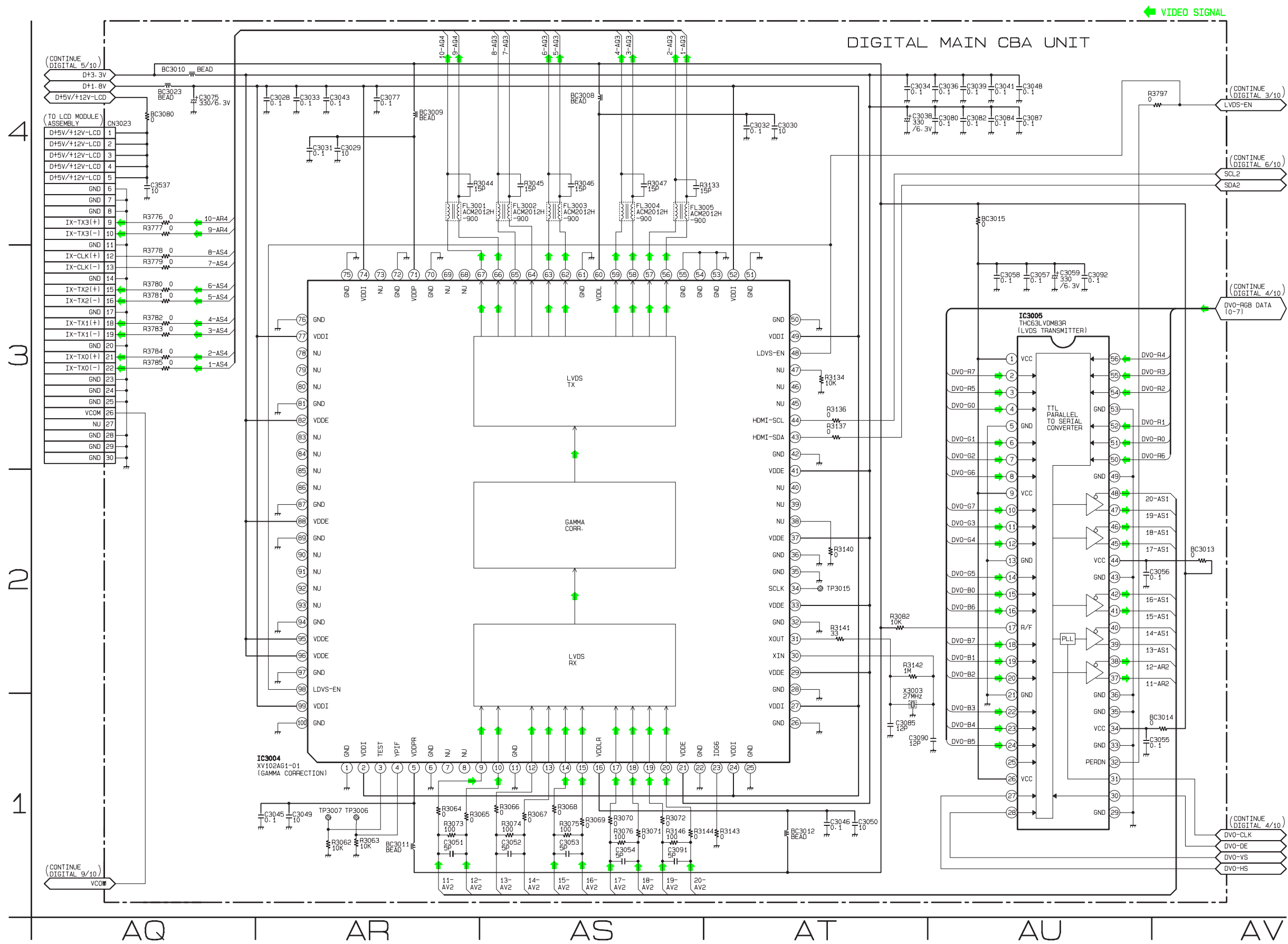

Digital Main 9/10 Schematic Diagram < LCD TV Section >

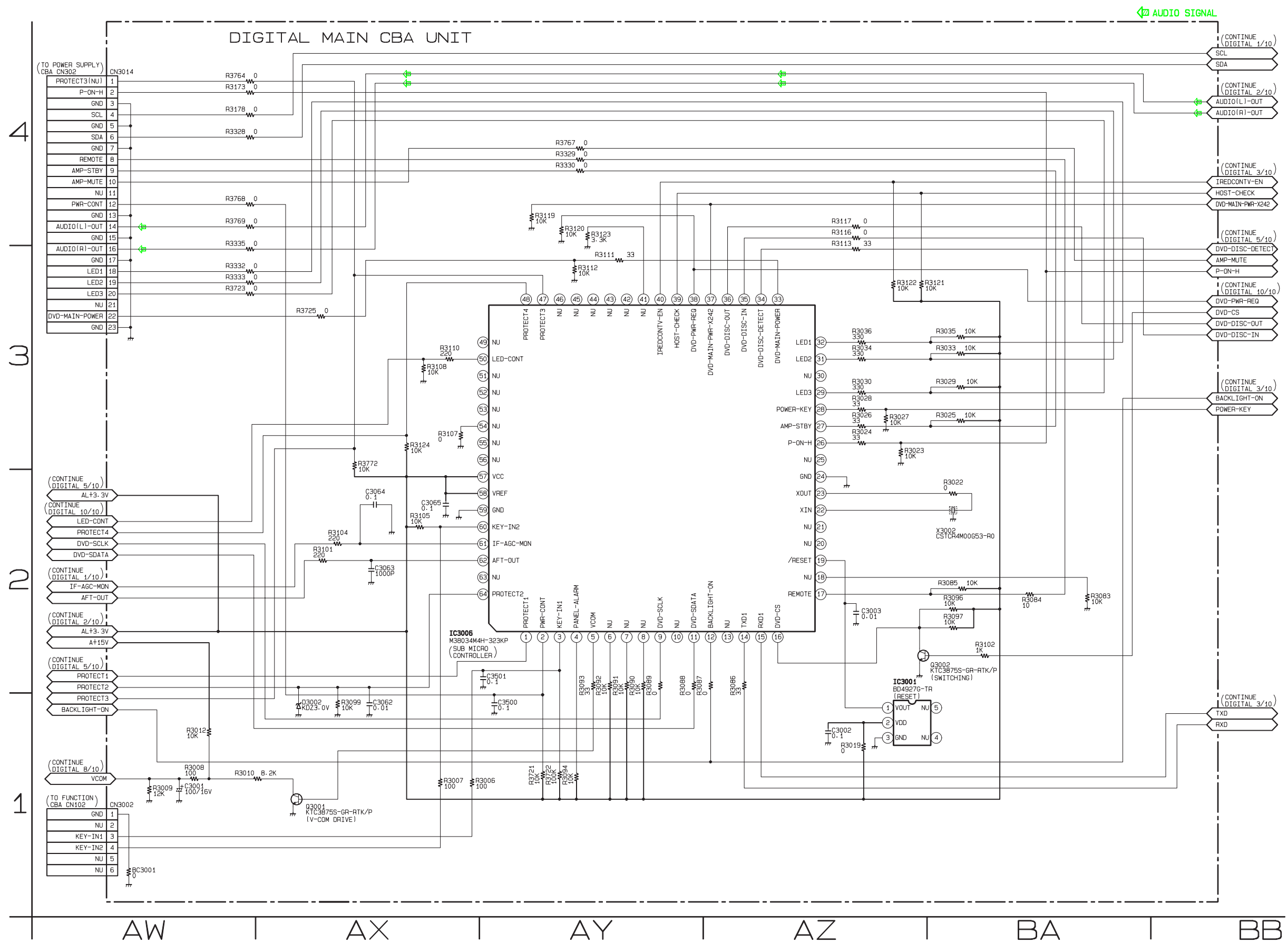

Digital Main 10/10 Schematic Diagram < LCD TV Section >

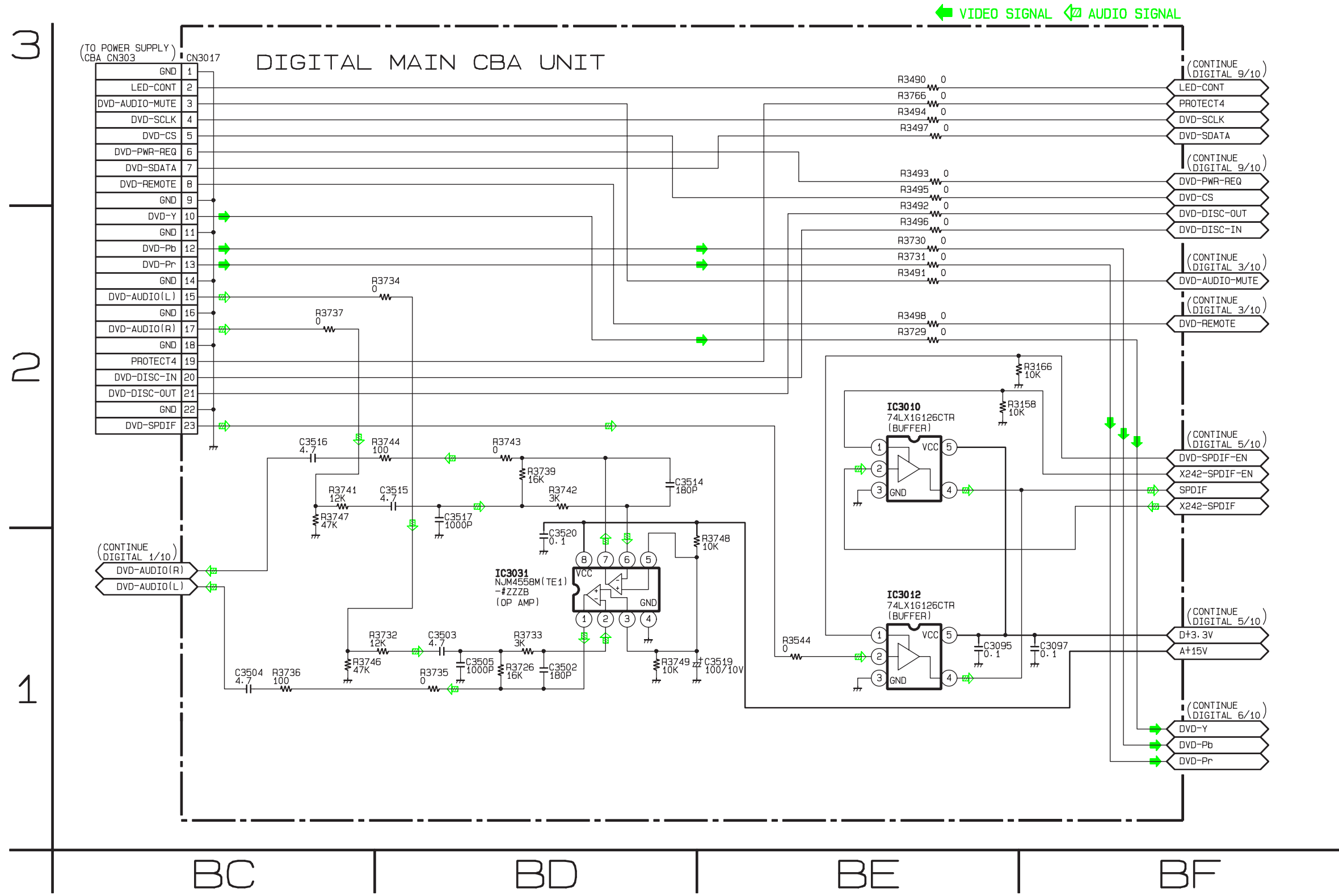

DVD Main 1/3 Schematic Diagram < DVD Section >

*1 NOTE:
Either IC461 or IC462 is used for DVD MAIN CBA UNIT.

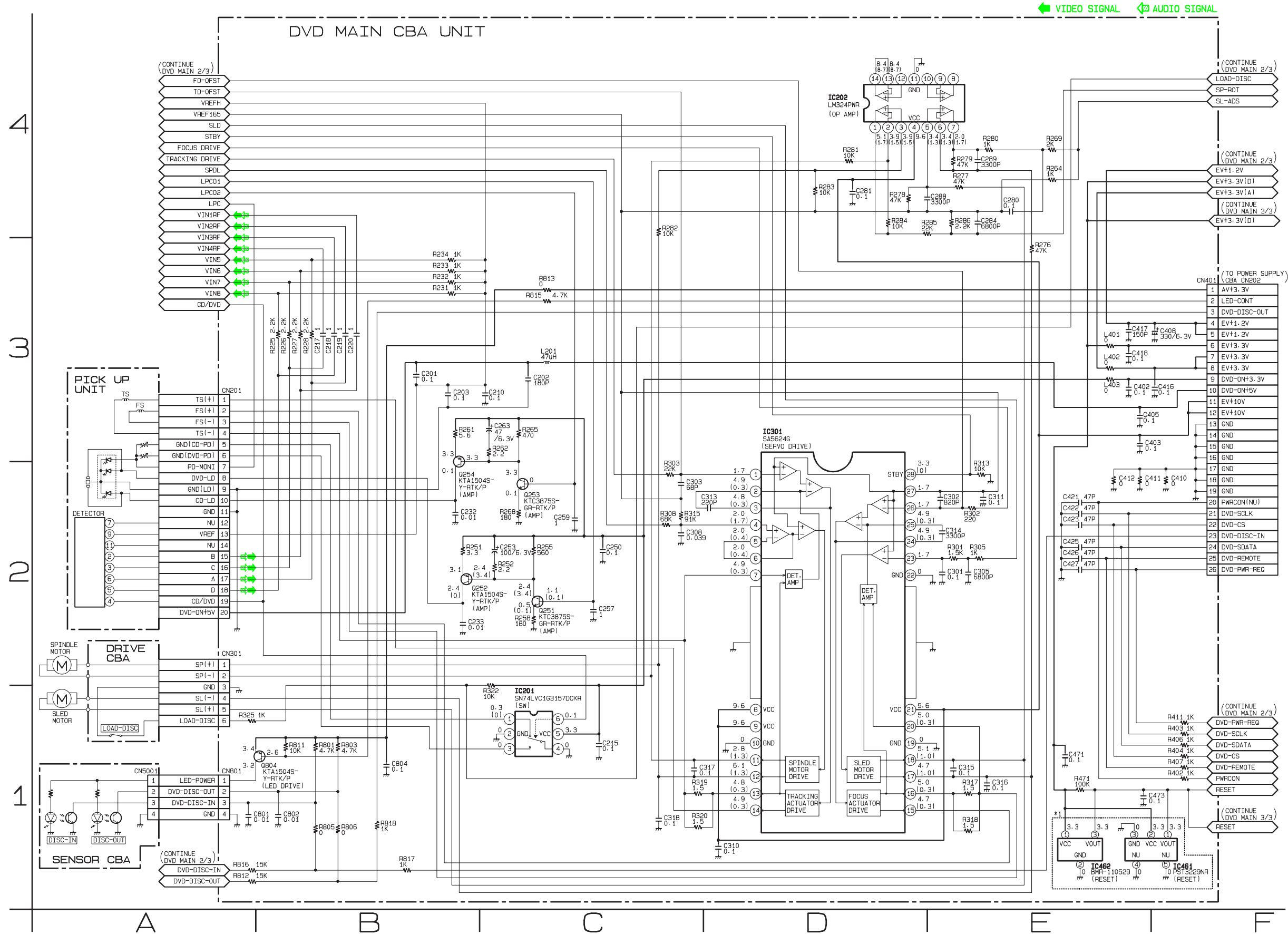

DVD Main 2/3 Schematic Diagram < DVD Section >

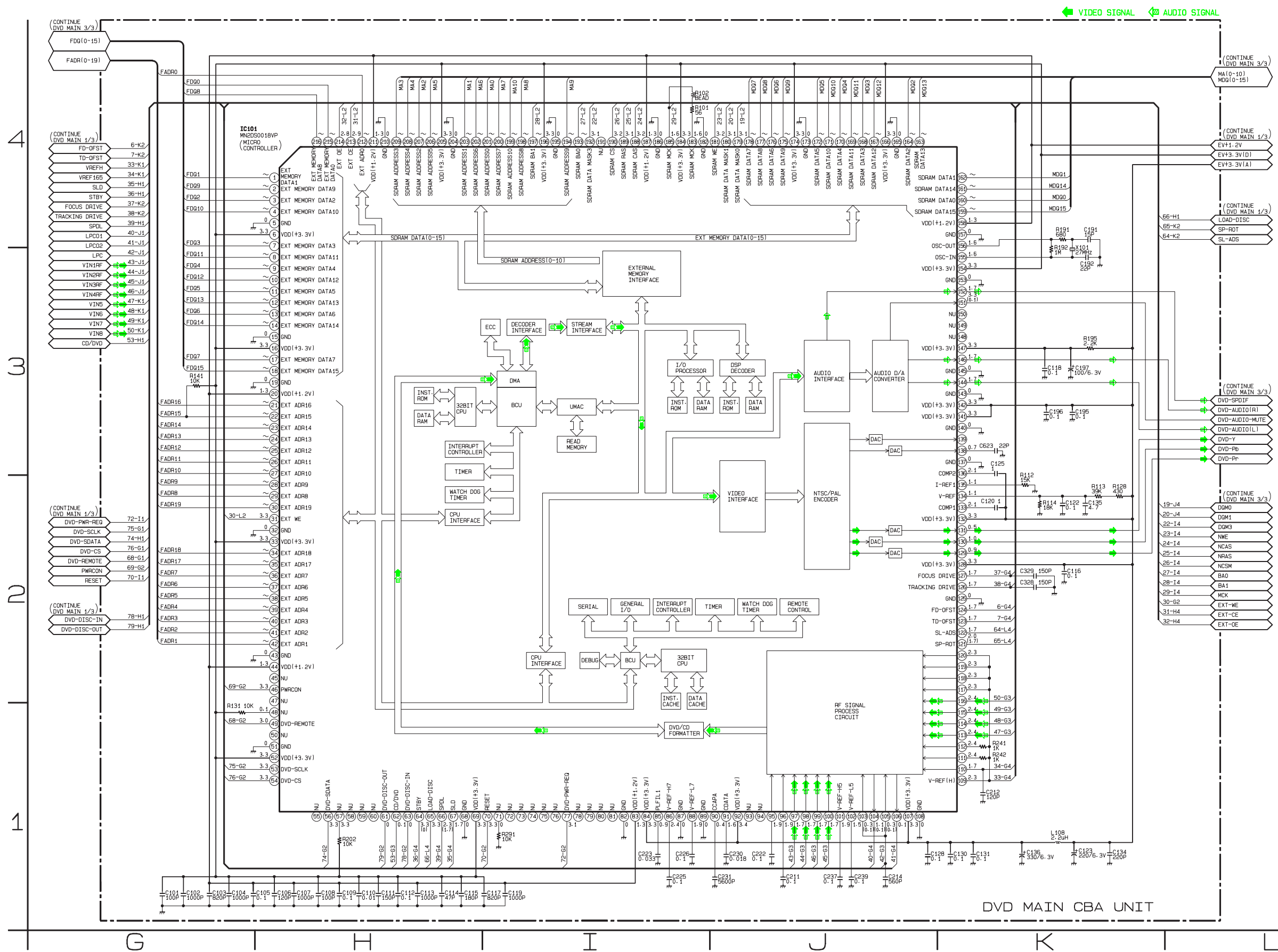

DVD Main 3/3 Schematic Diagram < DVD Section >

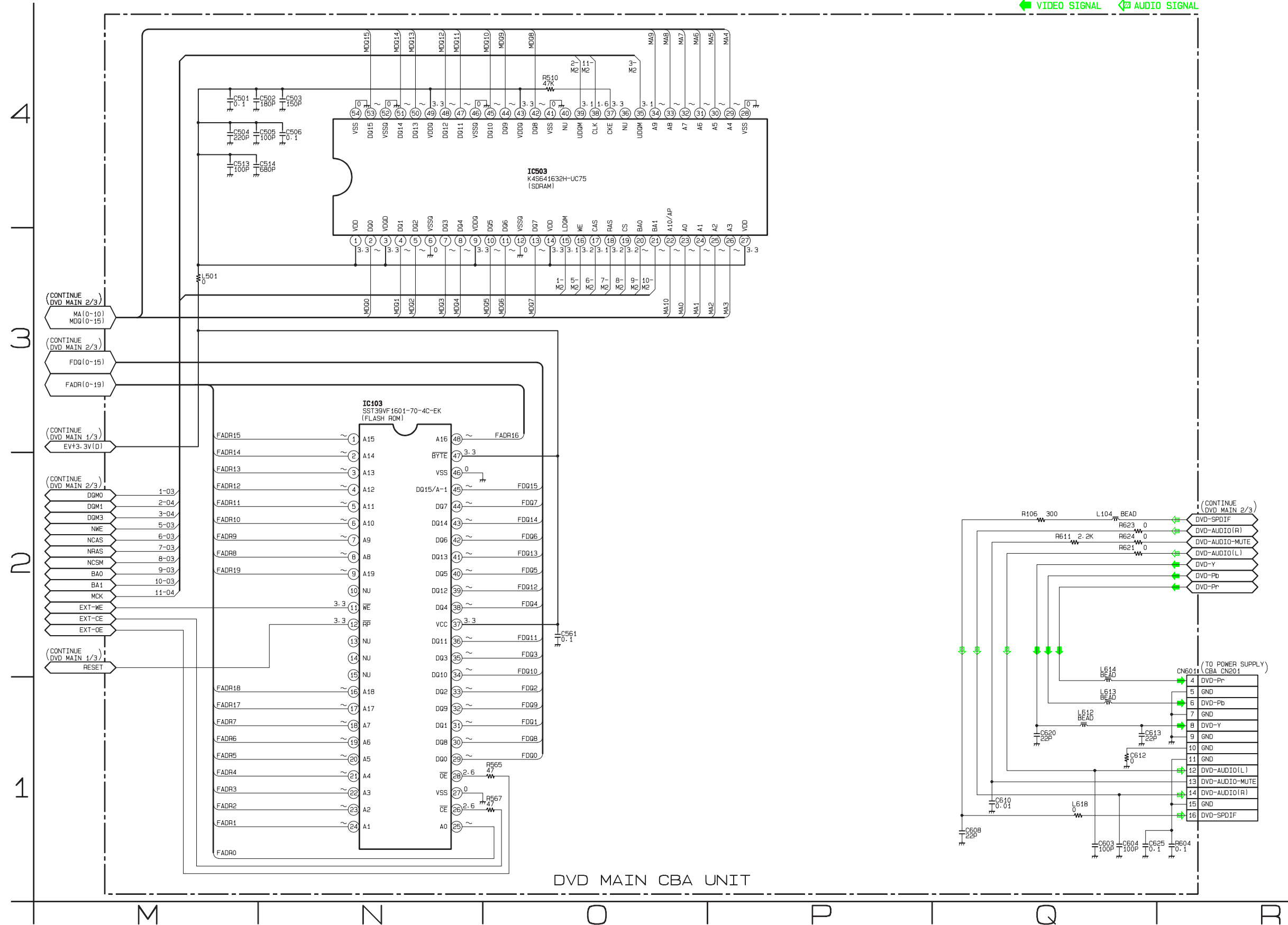

Power Supply CBA Top View

NOTE:
The voltage for parts in hot circuit is measured using hot GND as a common terminal.

Because a hot chassis ground is present in the power supply circuit, an isolation transformer must be used. Also, in order to have the ability to increase the input slowly, when troubleshooting this type power supply circuit, a variable isolation transformer is required.

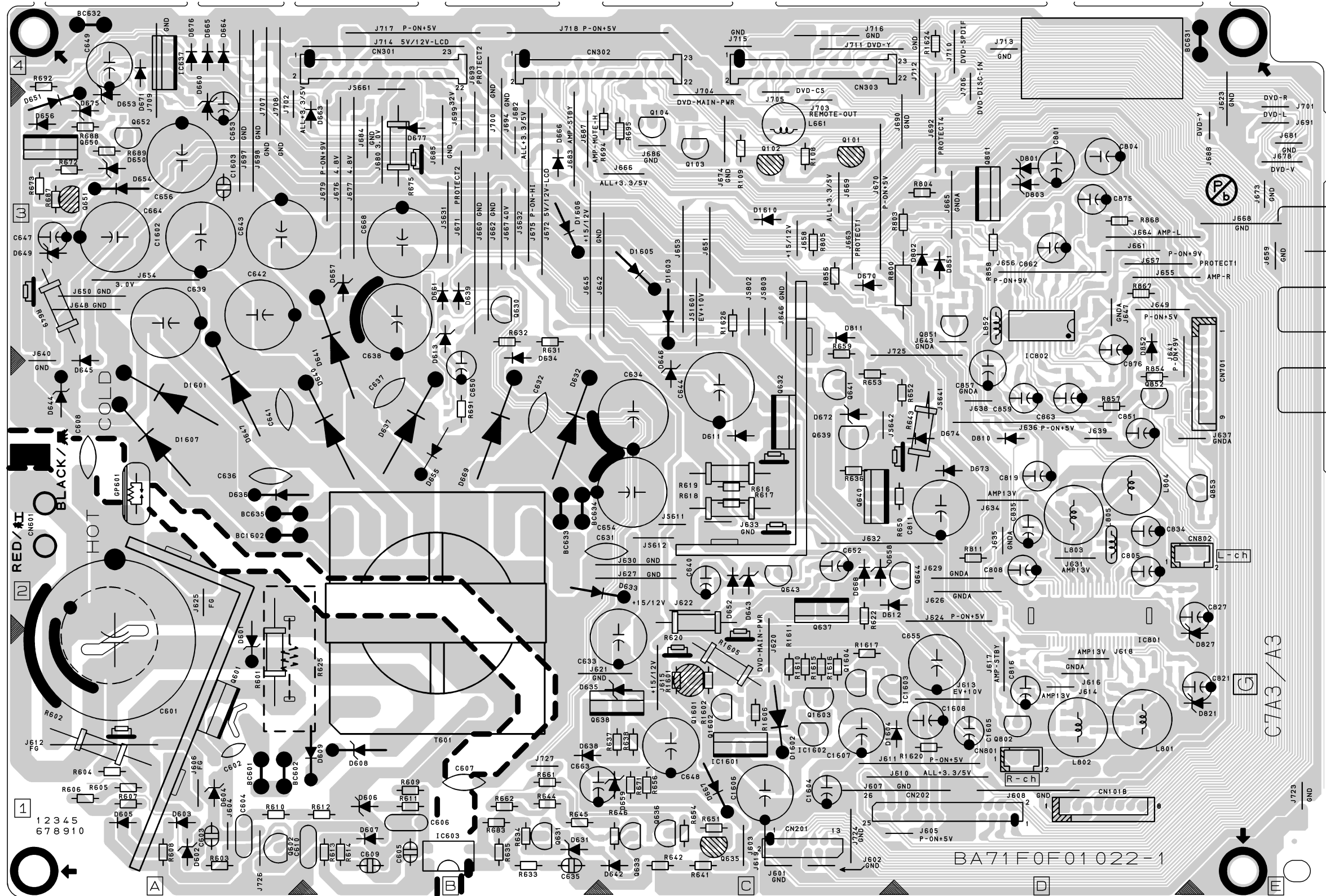

Power Supply CBA Bottom View

NOTE:
The voltage for parts in hot circuit is measured using hot GND as a common terminal.

Because a hot chassis ground is present in the power supply circuit, an isolation transformer must be used. Also, in order to have the ability to increase the input slowly, when troubleshooting this type power supply circuit, a variable isolation transformer is required.

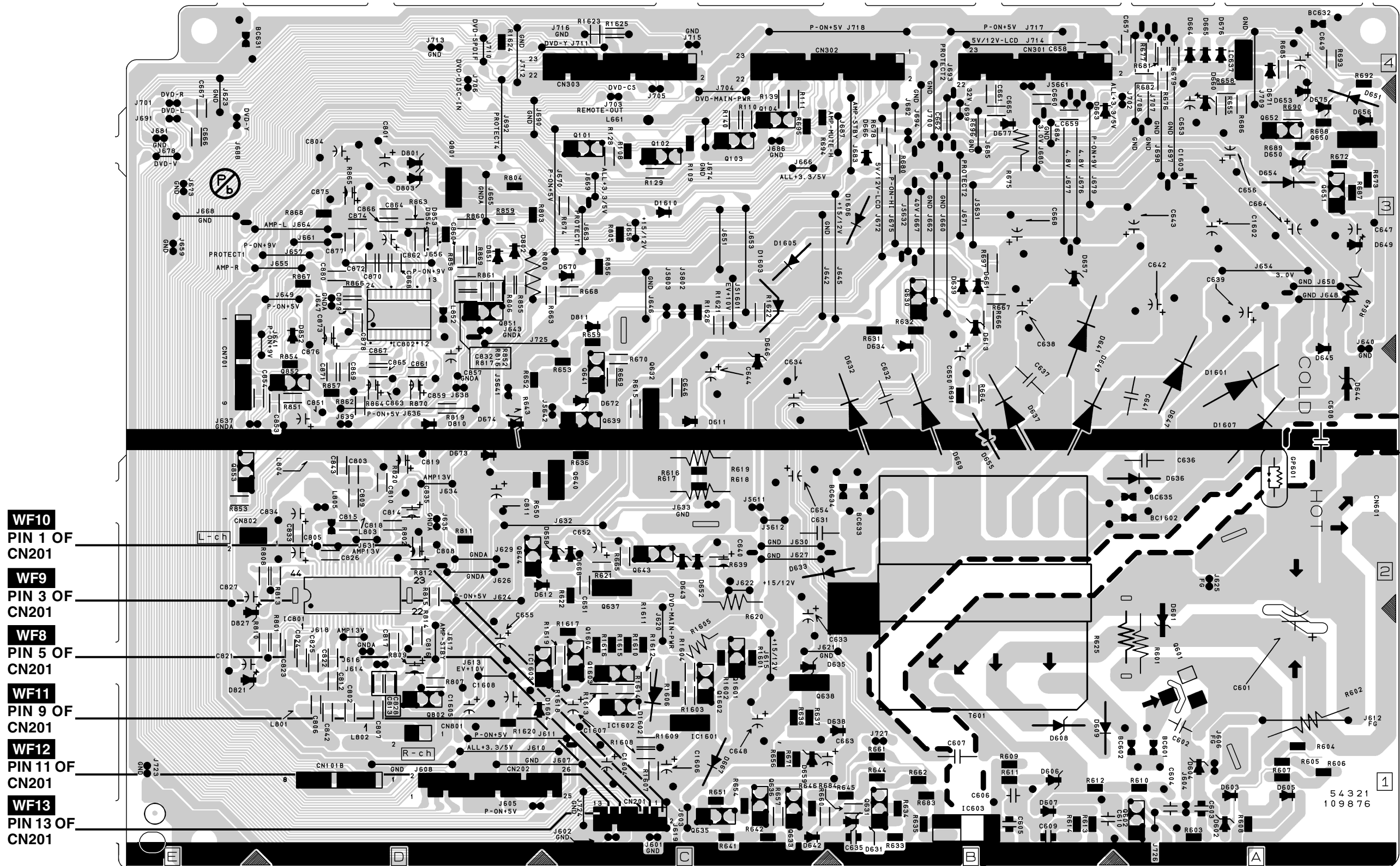

Inverter CBA Top View

CAUTION !

Fixed voltage (or Auto voltage selectable) power supply circuit is used in this unit.
If Main Fuse (F501) is blown, check to see that all components in the power supply circuit are not defective before you connect the AC plug to the AC power supply.
Otherwise it may cause some components in the power supply circuit to fail.

NOTE:

The voltage for parts in hot circuit is measured using hot GND as a common terminal.

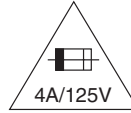

CAUTION ! : For continued protection against risk of fire, replace only with same type 4 A, 125V fuse.

ATTENTION : Utiliser un fusible de rechange de même type de 4A, 125V.

Because a hot chassis ground is present in the power supply circuit, an isolation transformer must be used. Also, in order to have the ability to increase the input slowly, when troubleshooting this type power supply circuit, a variable isolation transformer is required.

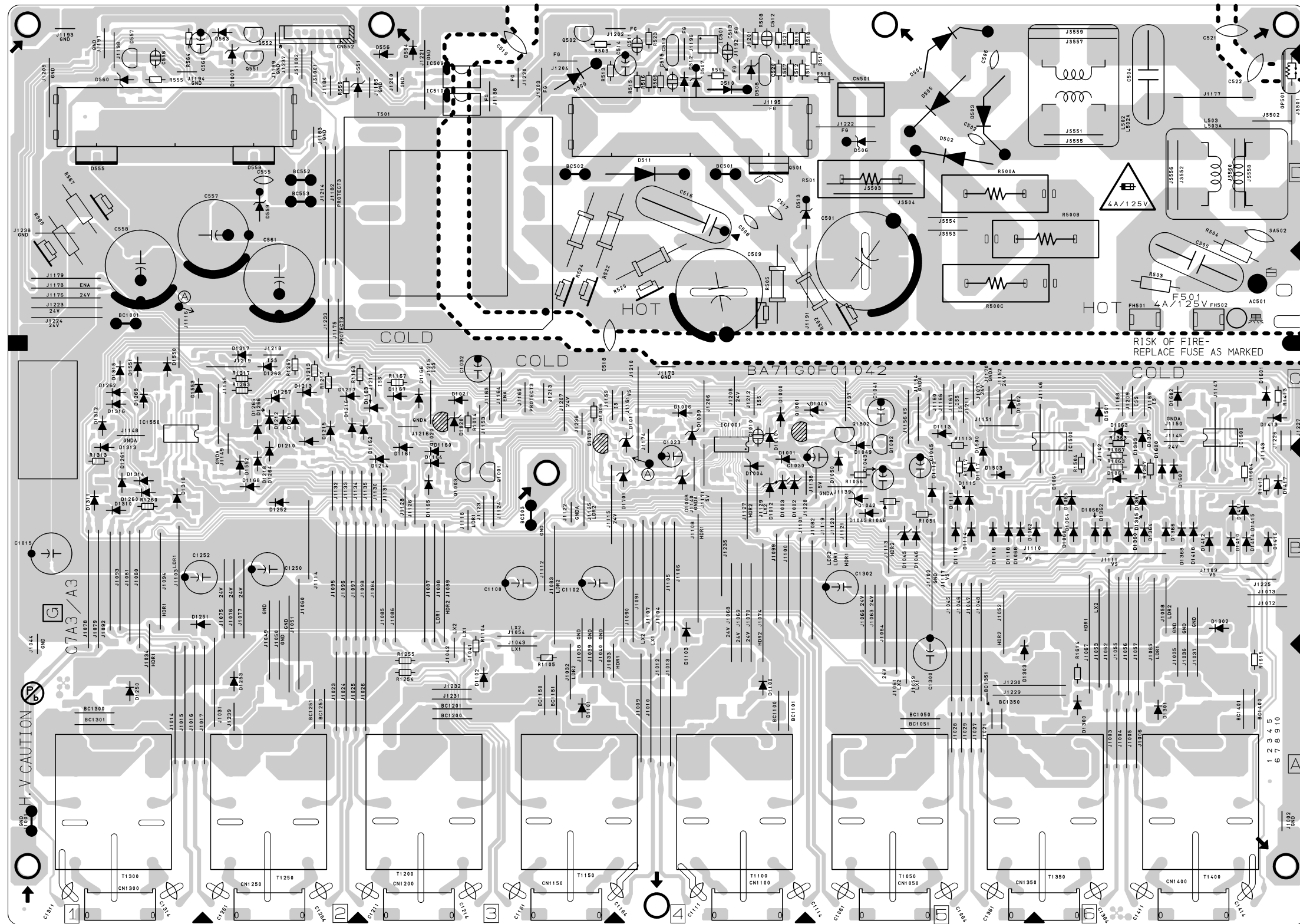

Inverter CBA Bottom View

CAUTION !

Fixed voltage (or Auto voltage selectable) power supply circuit is used in this unit.
 If Main Fuse (F501) is blown, check to see that all components in the power supply circuit are not defective before you connect the AC plug to the AC power supply.
 Otherwise it may cause some components in the power supply circuit to fail.

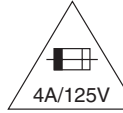

NOTE:

The voltage for parts in hot circuit is measured using hot GND as a common terminal.

CAUTION ! : For continued protection against risk of fire, replace only with same type 4 A, 125V fuse.

ATTENTION : Utiliser un fusible de rechange de même type de 4A, 125V.

Because a hot chassis ground is present in the power supply circuit, an isolation transformer must be used. Also, in order to have the ability to increase the input slowly, when troubleshooting this type power supply circuit, a variable isolation transformer is required.

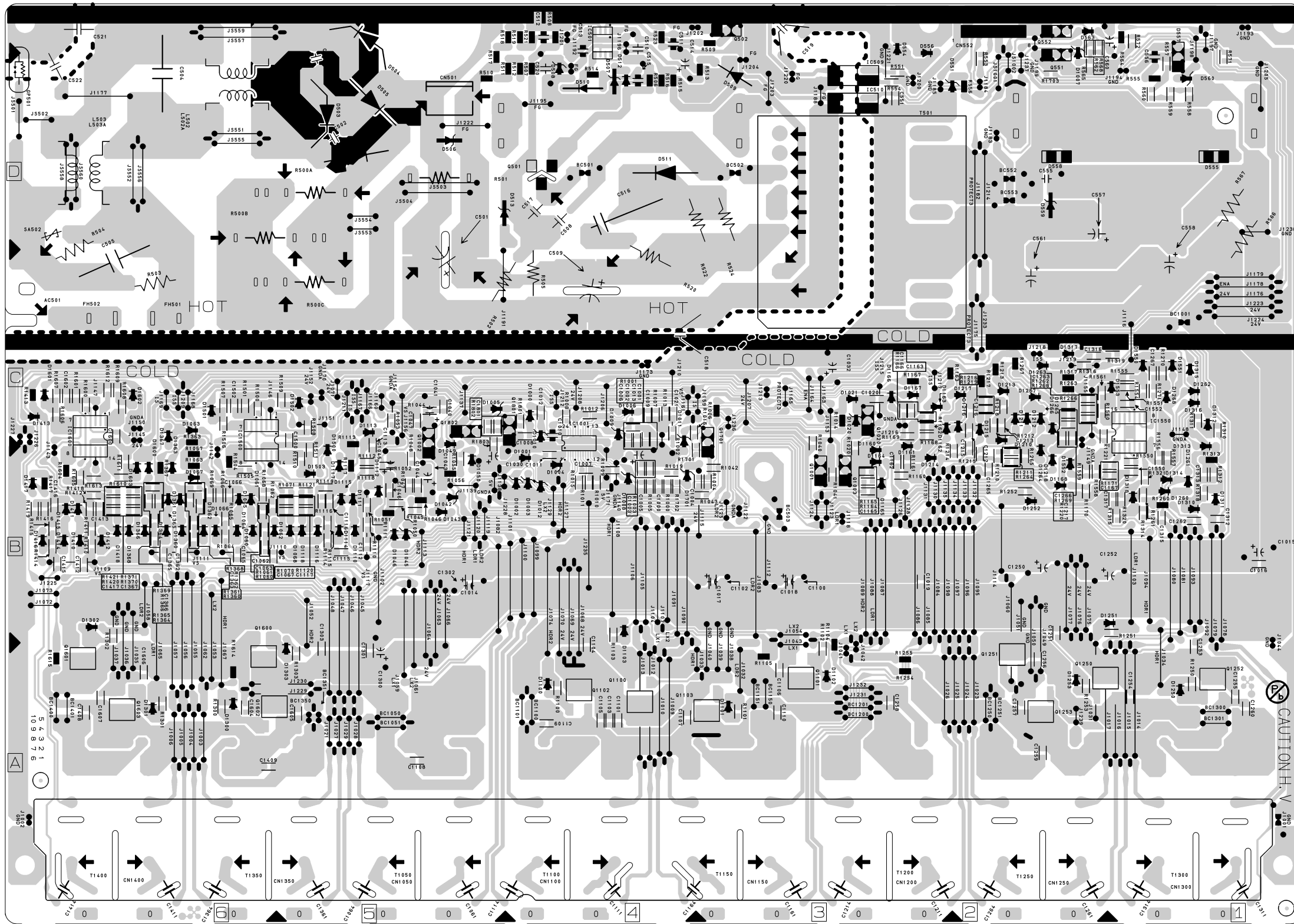

Jack CBA Top View

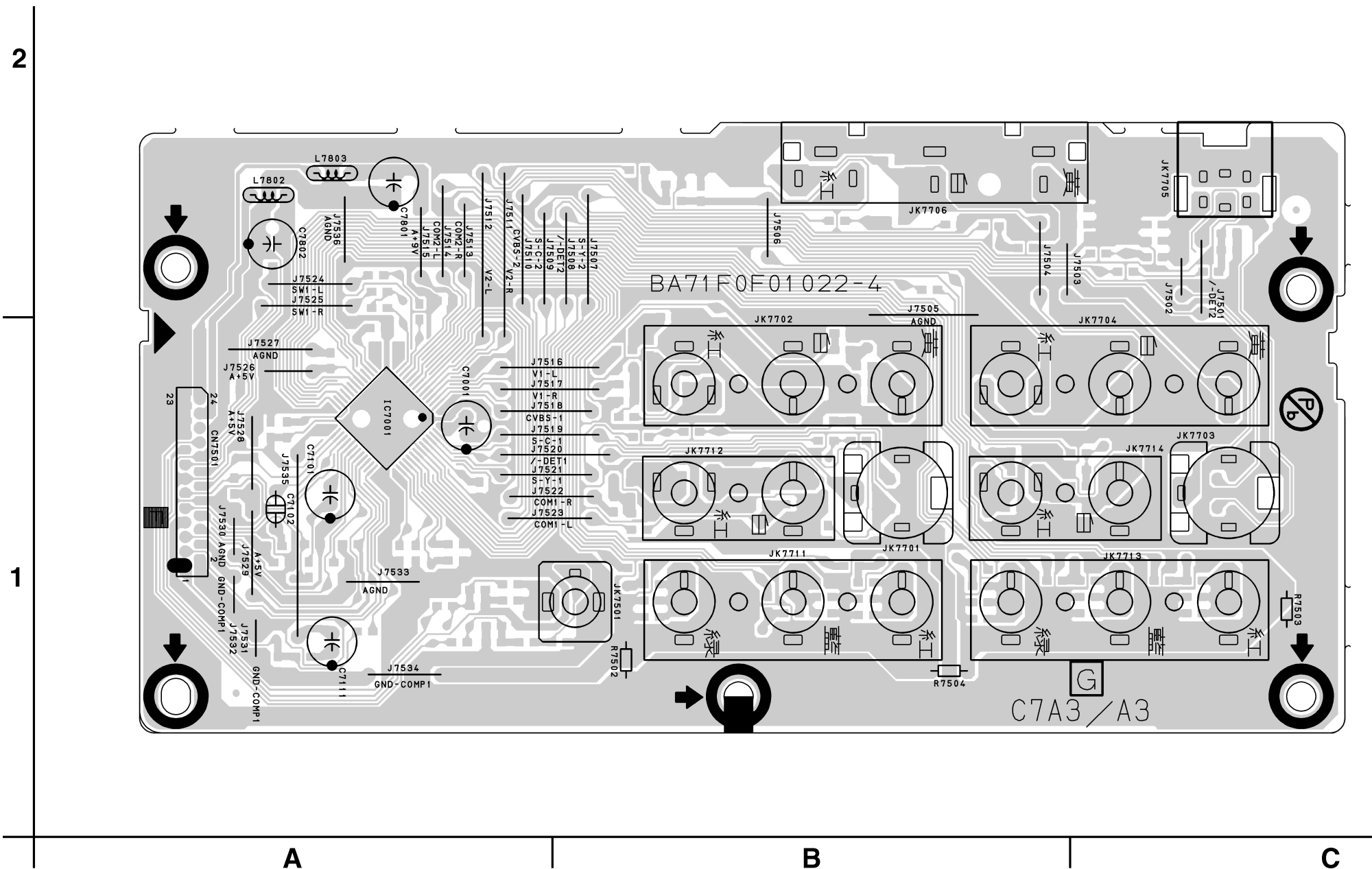

Jack CBA Bottom View

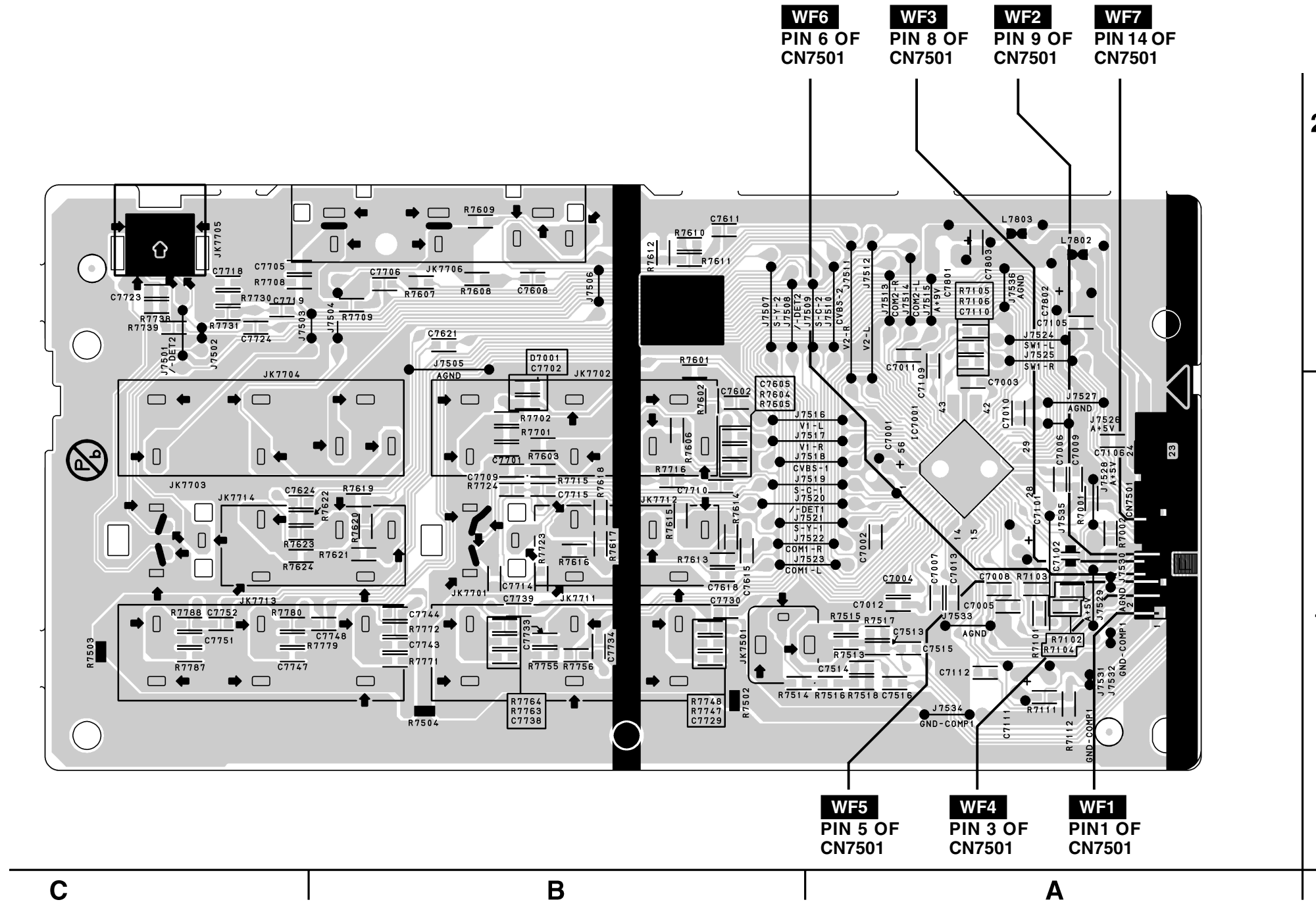

Function CBA Top View

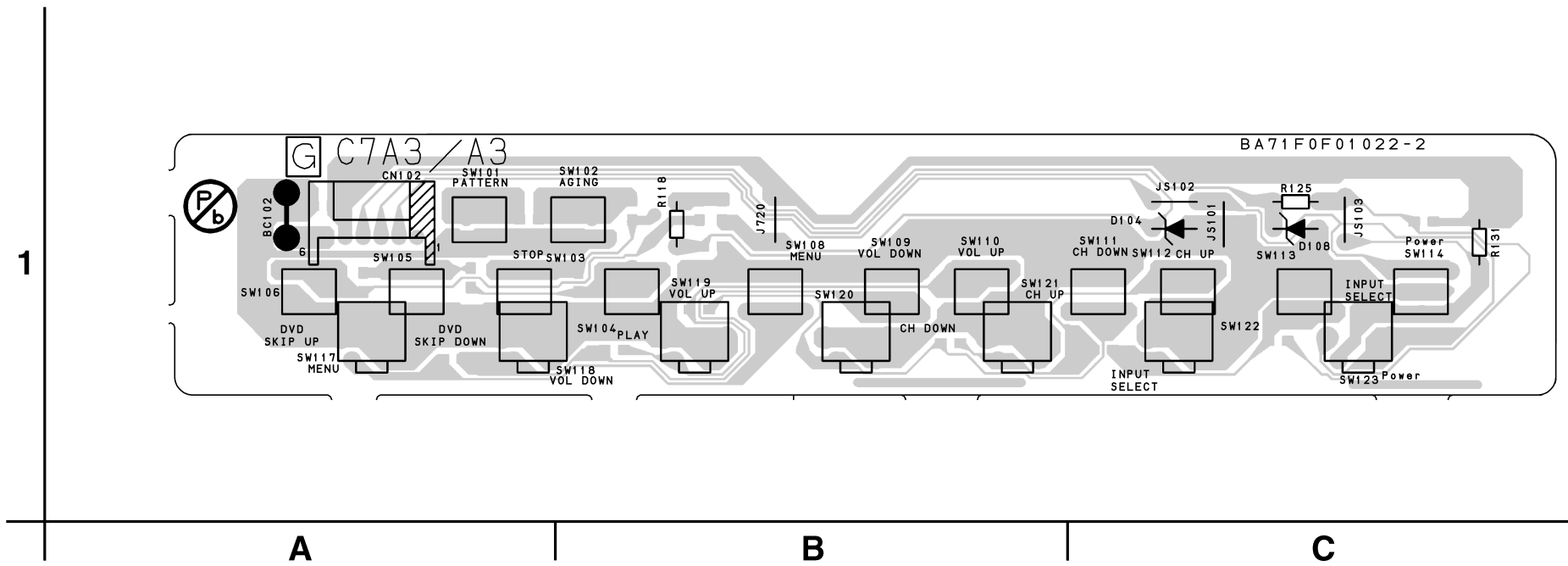

Function CBA Bottom View

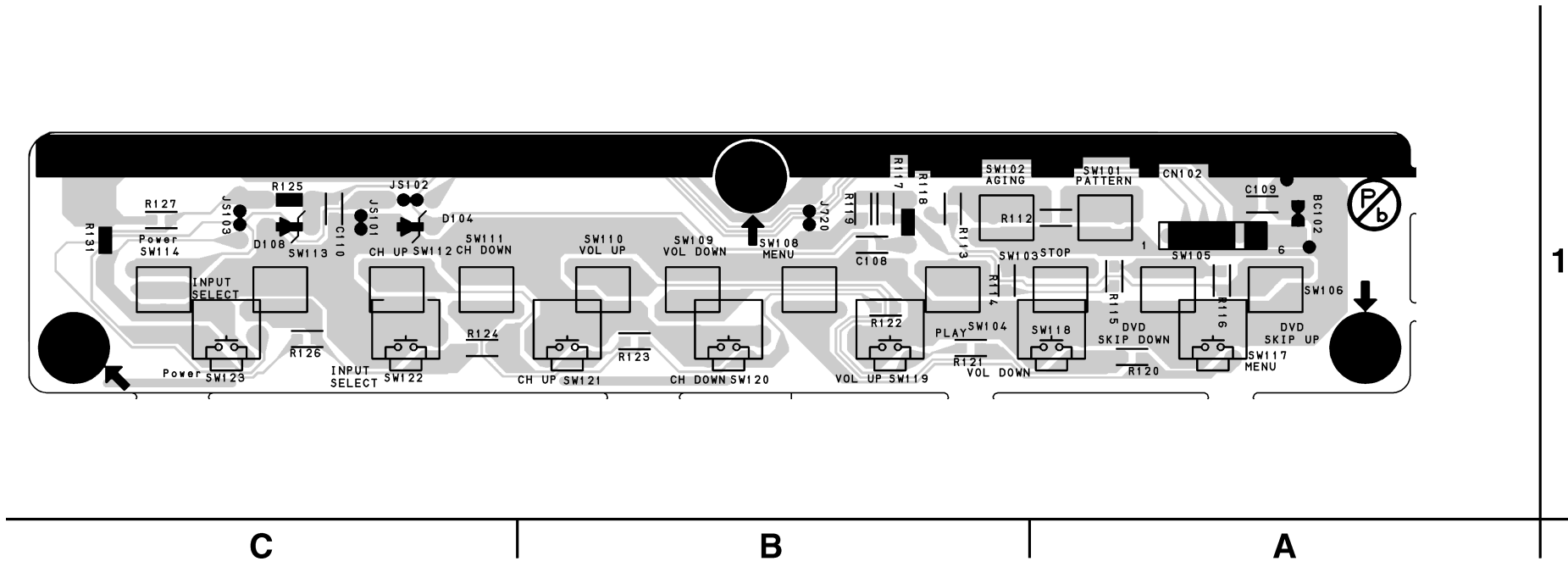

IR Sensor CBA Top View

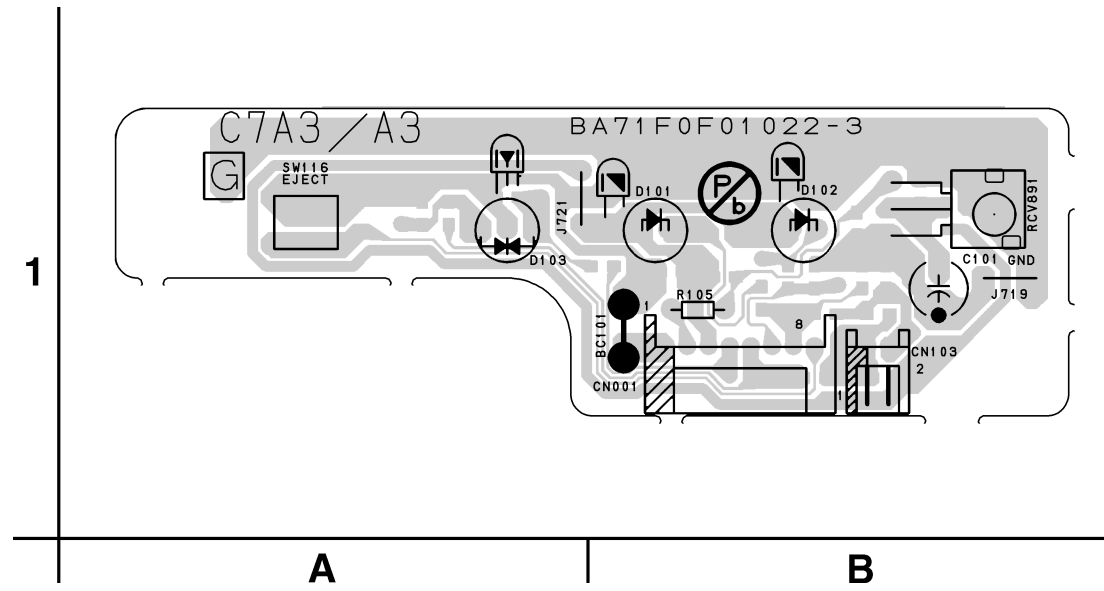

LED CBA Top & Bottom View

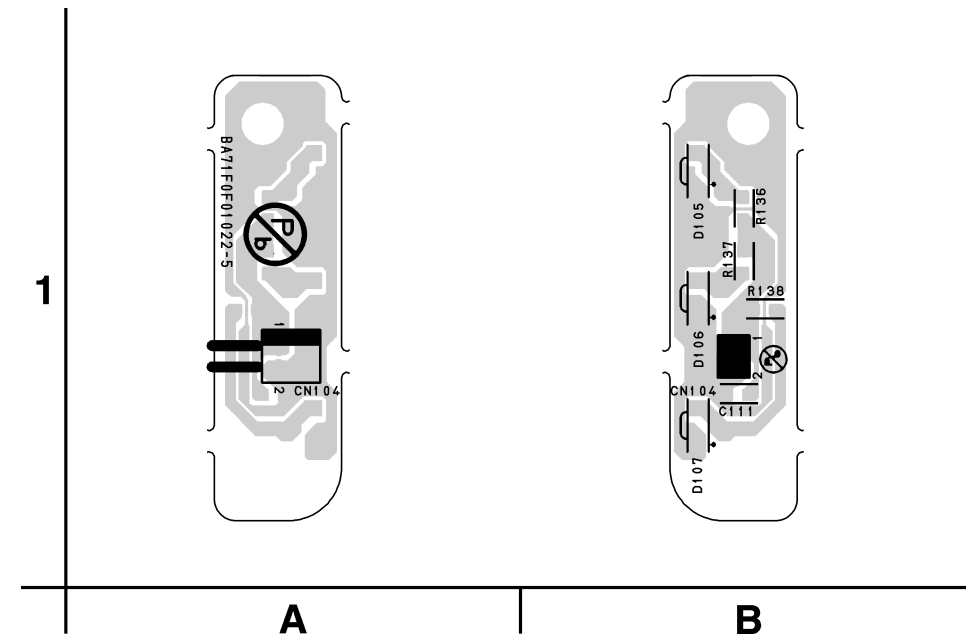

BA71F0F01022-5

IR Sensor CBA Bottom View

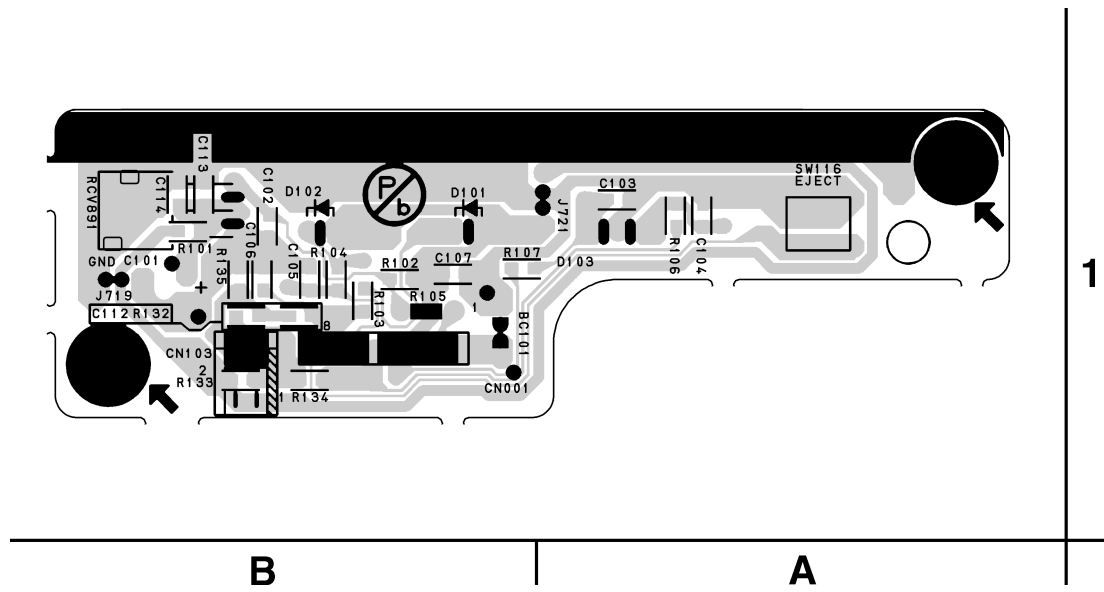

BA71F0F01022-3

WAVEFORMS < LCD TV SECTION >

WF1 ~ WF7 = Waveforms to be observed at
Waveform check points.
(Shown in Schematic Diagram.)

Input: NTSC Color Bar Signal (with 1kHz Audio Signal)

WF1 Pin 1 of CN7501

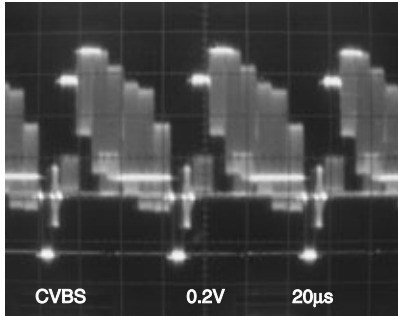

WF5 Pin 5 of CN7501

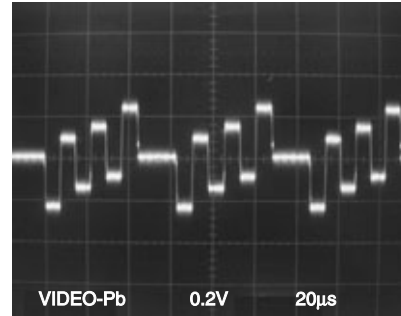

WF2 Pin 9 of CN7501

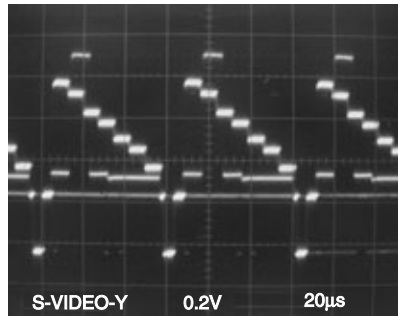

WF6 Pin 6 of CN7501

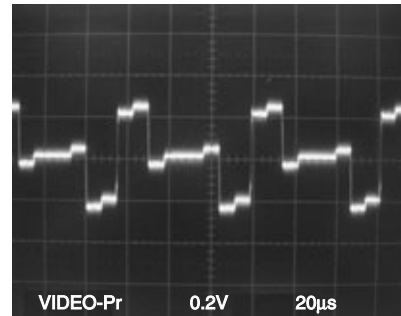

WF3 Pin 8 of CN7501

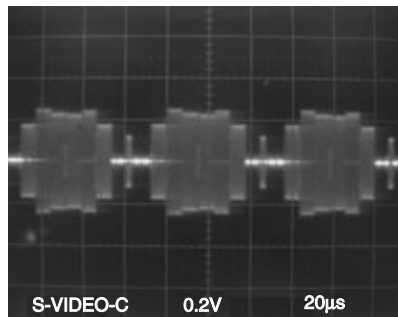

WF7 Pin 14 of CN7501

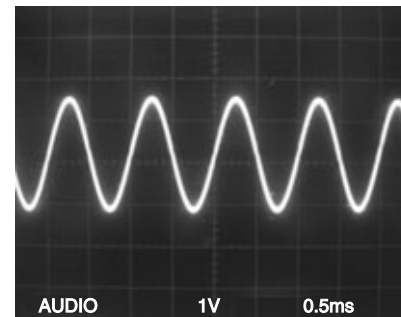

WF4 Pin 3 of CN7501

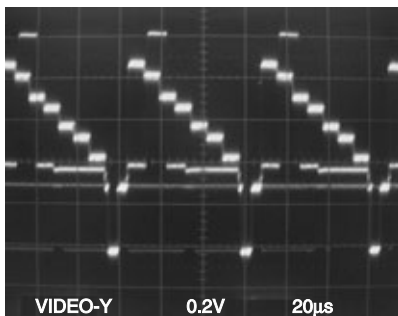

WAVEFORMS < DVD SECTION >

WF8 ~ WF13 = Waveforms to be observed at
Waveform check points.
(Shown in Schematic Diagram.)

Input: NTSC Color Bar Signal (with 1kHz Audio Signal)
DVD Video (Power on (Stop) MODE)

WF8 Pin 5 of CN201

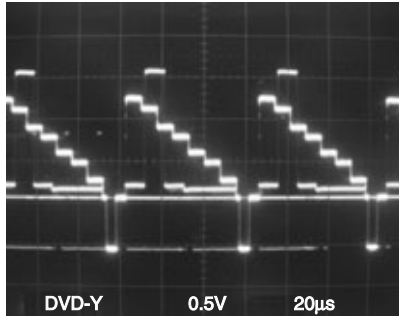

WF11 Pin 9 of CN201

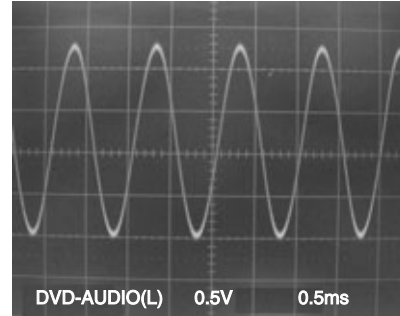

WF9 Pin 3 of CN201

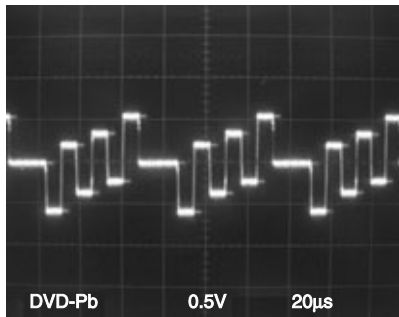

WF12 Pin 11 of CN201

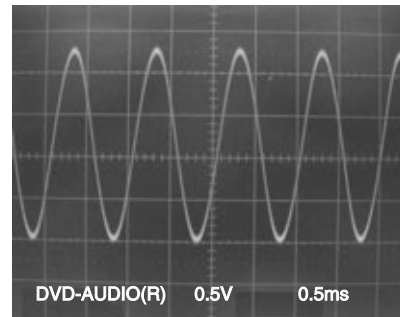

WF10 Pin 1 of CN201

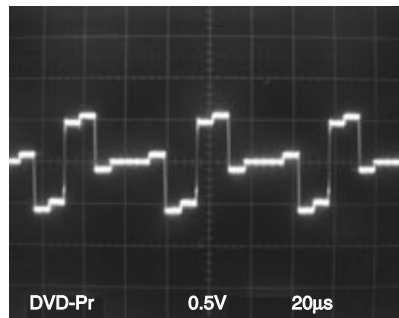

WF13 Pin 13 of CN201

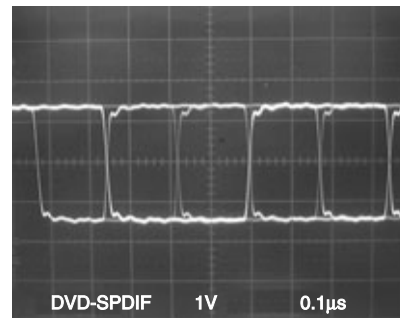

WIRING DIAGRAM < LCD TV SECTION >

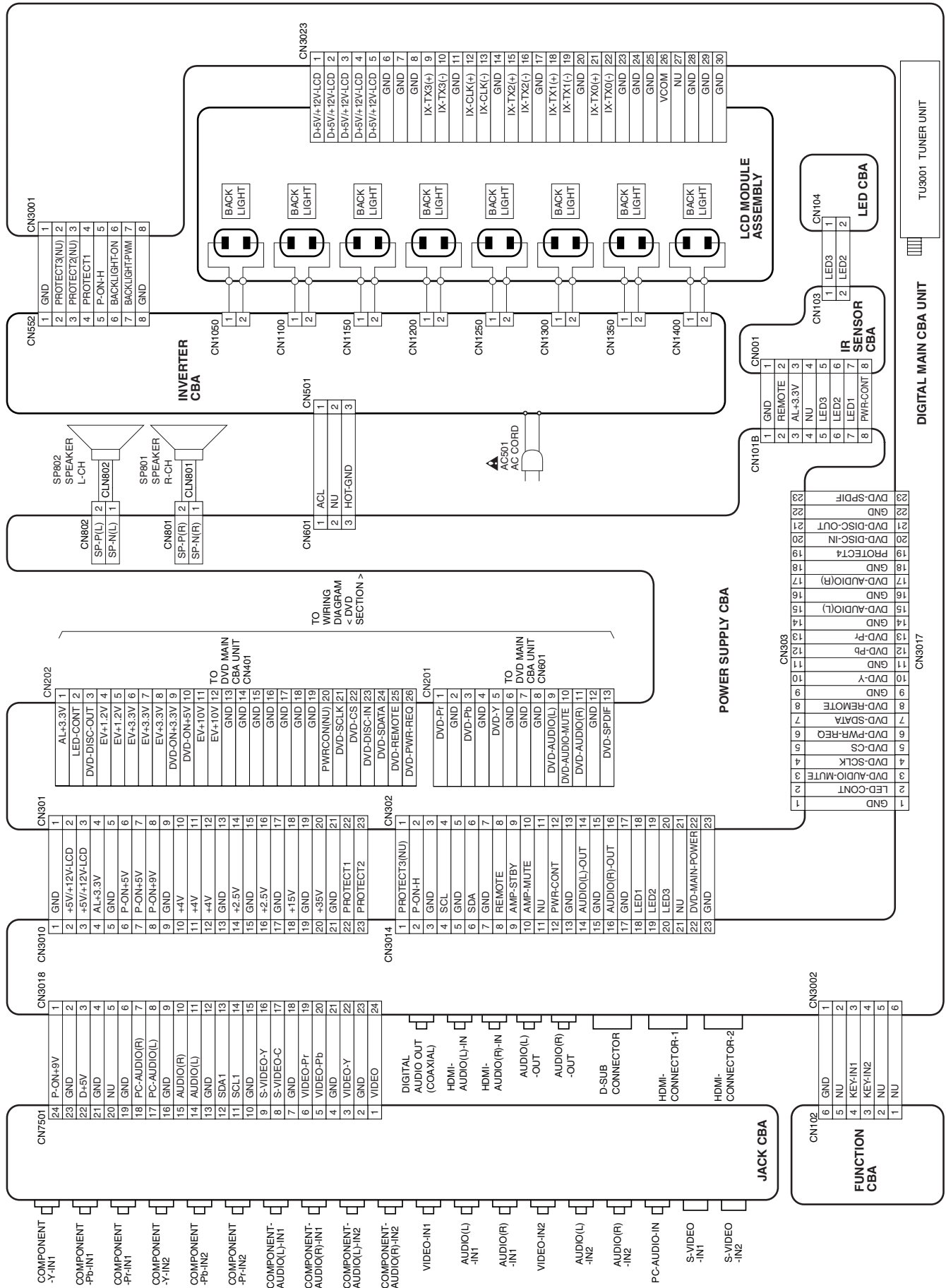

WIRING DIAGRAM < DVD SECTION >

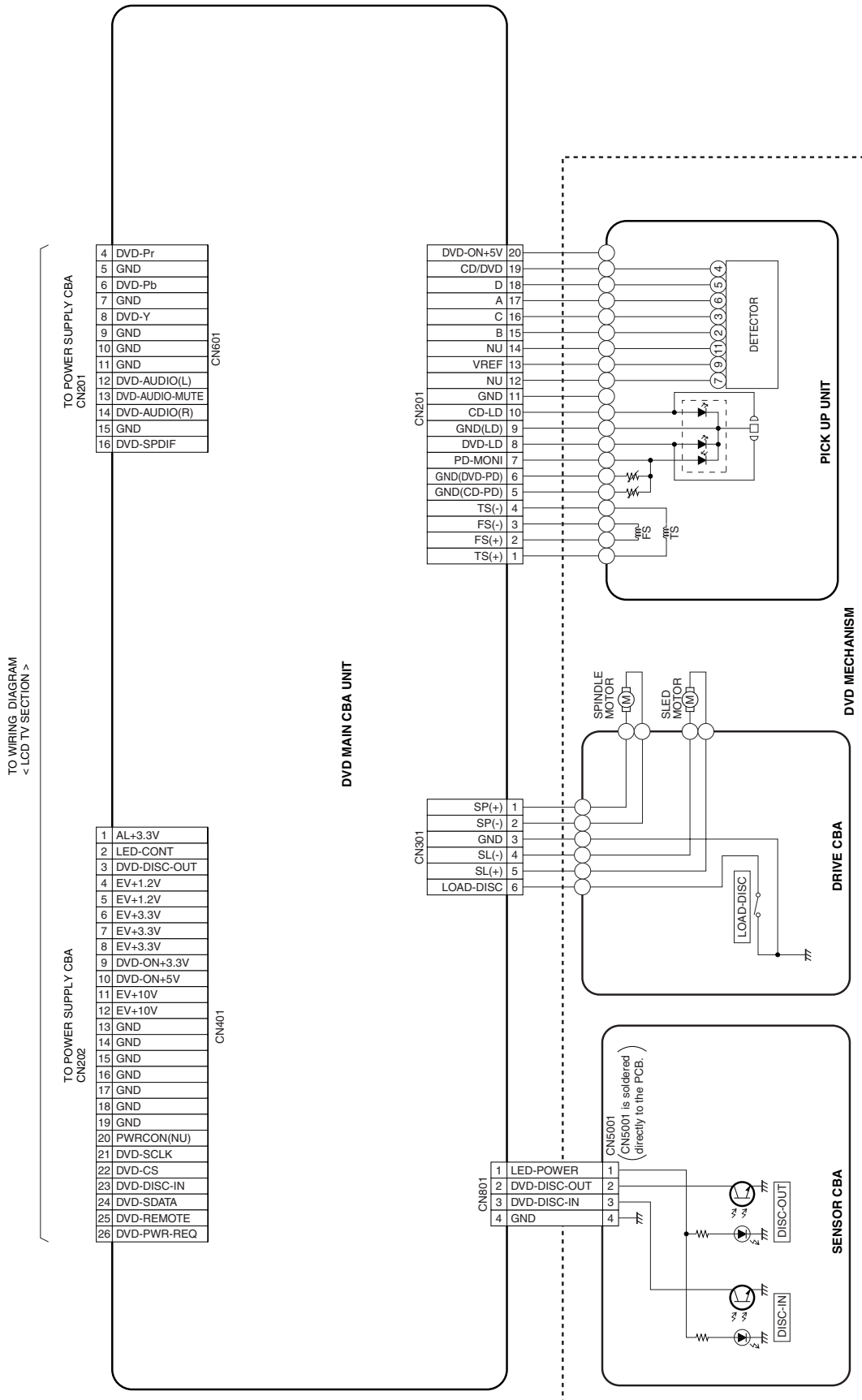

SYSTEM CONTROL TIMING CHARTS

Disc In ~ Play/Play ~ Disc Out

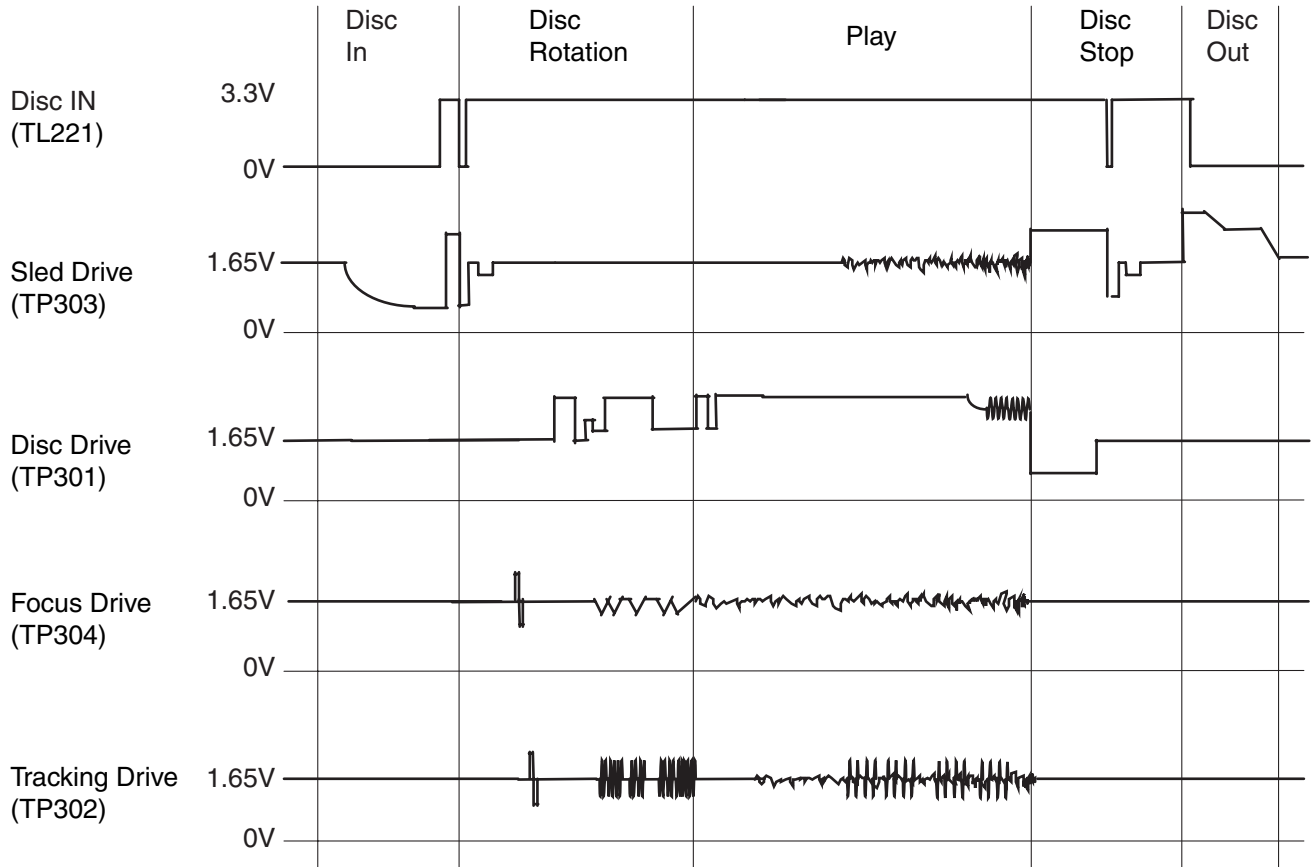

LEAD IDENTIFICATIONS

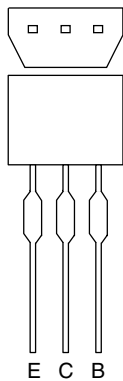

KTA1267-GR-AT/P
KTA1281Y-AT/P
KTC3199-GR-AT/P

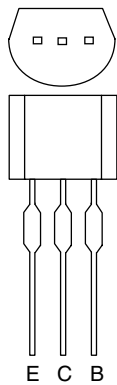

2SC2120-(O, Y) (TE2 F T)
2SD400(F)

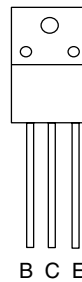

2SA1887(F)

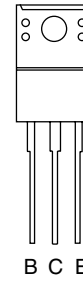

KTC2026-Y/P

KIA431-AT/P

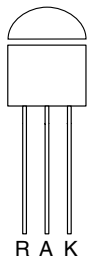

LV1115M-TLE-E
OZ9966SN-B1-0-TR/SSO

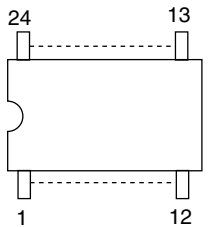

BD5422EFS-E2

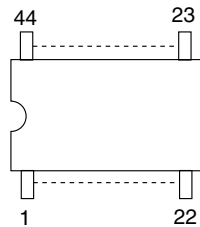

R2A11011FP

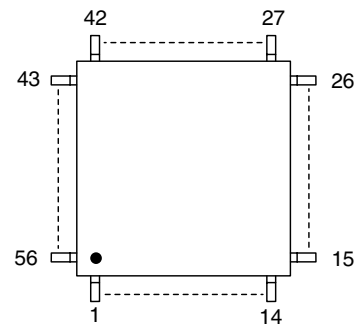

BA10324AF-E2

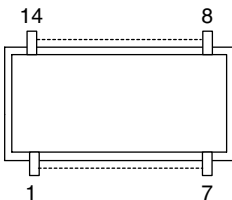

LD1117V

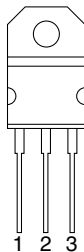

1: Vin
2: Vo
3: GND

2SK3568(Q)

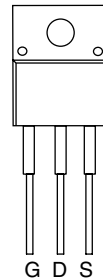

2SK3561(Q)

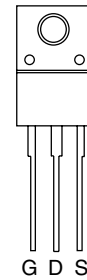

UCC28600DR

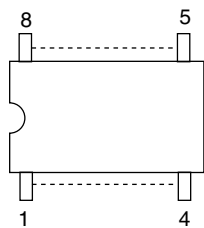

NP22N055SLE-E1-AZ

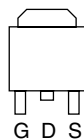

LTV817MBF
LTV817MCF

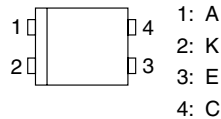

1: A
2: K
3: E
4: C

Note:

- A: Anode
- K: Cathode
- E: Emitter
- C: Collector
- B: Base
- R: Reference
- S: Source
- G: Gate
- D: Drain

EXPLODED VIEWS

Cabinet

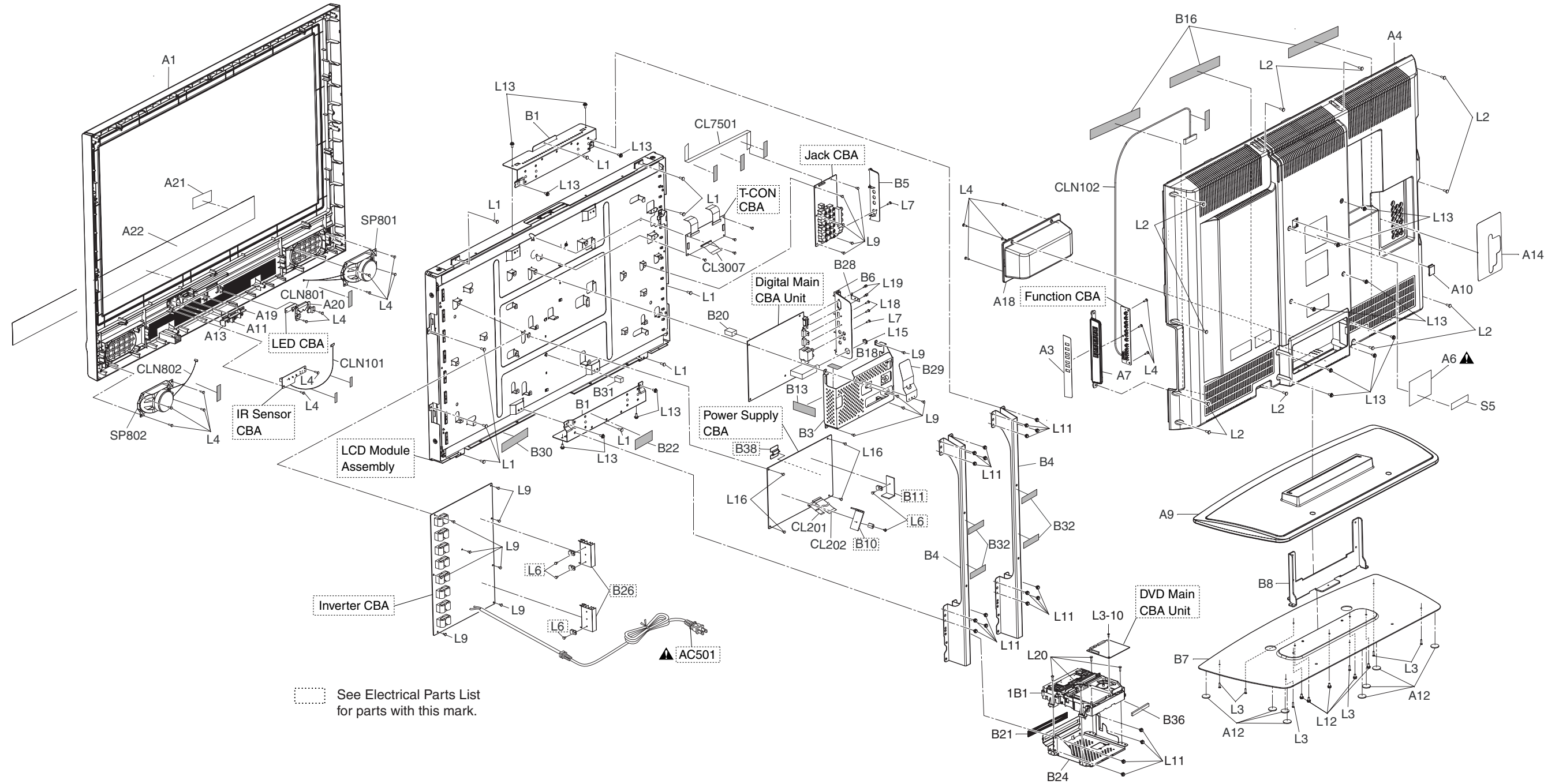

Packing

Some Ref. Numbers are not in sequence.

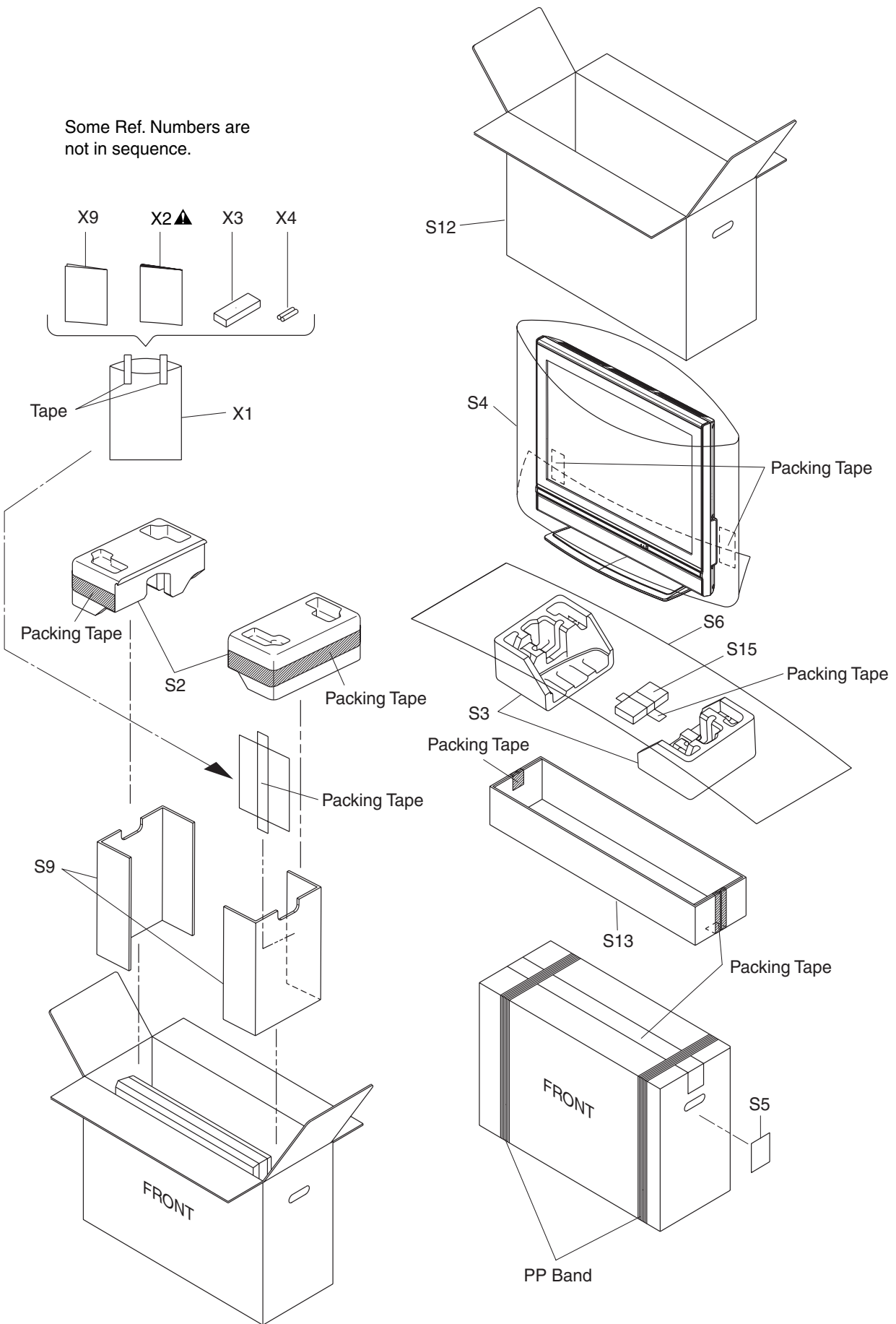

MECHANICAL PARTS LIST

PRODUCT SAFETY NOTE: Products marked with a **▲** have special characteristics important to safety. Before replacing any of these components, read carefully the product safety notice in this service manual. Don't degrade the safety of the product through improper servicing.

NOTE: Parts that are not assigned part numbers (-----) are not available.

Ref. No.	Description	Part No.
A1	FRONT CABINET 37VD A74G0UH	1EM021701
A3	CONTROL PLATE A74FOUH	1EM322602A
A4	REAR CABINET 37VD A74G0UH	1EM021702
A6 ▲	RATING LABEL A74G0UH	-----
A7	FUNCTION KNOB A74FOUH	1EM221571
A9	STAND COVER 37V A71G0UH	1EM021653
A10	REAR COVER A7260JH	1EM322484
A11	LED LENS A71FOUH	1EM322469
A12	STAND RUBBER FOOT L5001CB	1EM423855
A13	SENSOR LENS A71FOUH	1EM322470
A14	JACK PLATE A71FOUH	1EM221551
A18	DVD COVER A74F0UH	1EM021660
A19	EJECT KNOB A74F0UH	1EM322600
A20	ILLUMINATION LENS A74F0UH	1EM322599
A21	POP LABEL A71FOUH	-----
A22	PUNCHING SHEET A71G0UH	1EM021711
1B1	DVD MECHA SLOT E7 N7XT0KVM	N7XT1KVM
B1	PANEL HOLDER UD 37V A71G0UH	1EM121830
B3	SHIELD BOX A71FOUH	1EM121832
B4	CHASSIS BRACKET 37V A71G0UH	1EM021651
B5	JACK HOLDER(A) A71FOUH	1EM221530
B6	JACK HOLDER(D) A71FOUH	1EM221535
B7	STAND BASE PLATE 37V A71G0UH	1EM021652
B8	STAND HINGE A71FOUH	1EM221532
B13	GRAND TAPE L4300UA	1EM423095
B16	CLOTH(10X180XT0.5) L0336JG	0EM408827
B18	CLOTH(10X30XT0.5) B5900UA	0EM404486
B20	GASKET A71G0UH	1EM424526
B21	FELT A74F0UH	1EM424374
B22	LASER CAUTION LABEL A74F0UH	-----
B24	DVD HOLDER A74F0UH	1EM121895
B28	EARTH PLATE A71FOUH	1EM424389
B29	SHIELD PLATE A71G0UH	1EM322615
B30	CLOTH(15X110XT 0.5) L0110UA	0EM408385
B31	RUBBER CUSHION A71G0UH	1EM424424
B32	GRAND TAPE (TR-19) A71FOUH	1EM424512
B36	CUSHION(80X10XT6) A71FOUH	1EM424511
CL201	WIRE ASSEMBLY 13PIN FFC 13PIN/332MM	WX1A74G0-101
CL202	WIRE ASSEMBLY 26PIN FFC 26PIN/237MM	WX1A74G0-102
CL3007	WIRE ASSEMBLY 101 30PIN / 70MM	WX1A71G0-101
CL7501	WIRE ASSEMBLY 102 24PIN / 475MM	WX1A71G0-102
CLN101	WIRE ASSEMBLY 003 8PIN / 510MM / AWG26	WX1A74G0-003
CLN102	WIRE ASSEMBLY 002 6PIN / 1160MM / AWG2	WX1A71G0-002
CLN801	WIRE ASSEMBLY 006 2PIN / 740MM / AWG22	WX1A74G0-006
CLN802	WIRE ASSEMBLY 006 2PIN / 450MM / AWG22	WX1A71F0-006
L1	SCREW P-TIGHT 4X14 BIND HEAD	GBJP4140
L2	SCREW P-TIGHT M4X14 BIND HEAD+BLK	GBHP4140
L3	SCREW P-TIGHT M3X12 DISH HEAD+	GDJP3120

Ref. No.	Description	Part No.
L3-10	SCREW P-TIGHT M3X8 BIND HEAD+	GBJP3080
L4	SCREW P-TIGHT 3X10 BIND HEAD+	GBJP3100
L7	SCREW B-TIGHT 3X10 BIND HEAD+ BLK	GBHB3100
L9	SCREW S-TIGHT M3X6 BIND HEAD+	GBJS3060
L11	DOUBLE SEMS SCREW M4X6 M4X6	FPJ34060
L12	DOUBLE SEMS SCREW M4X9 + BLACK L0130UA	0EM408146A
L13	DOUBLE SEMS SCREW M4X10 + BLK	FPH34100
L15	NUT 3/8-32UNEF	0EM401451A
L16	ASSEMBLED SCREW (D9 M3X6) A71FOUH	1EM424392
L18	SCREW S-TIGHT M3X8 BIND HEAD+	GBHS3080
L19	HEX SCREW #4-40 7MM	1EM422042
L20	SCREW S-TIGHT M3X10 BIND HEAD+	GBJS3100
SP801	SPEAKER MAGNETIC YDP613-1FN	DSD0811EFU01
SP802	SPEAKER MAGNETIC YDP613-1FN	DSD0811EFU01
PACKING		
S2	STYROFOAM TOP 37V A71G0UH	1EM021655
S3	STYROFOAM BOTTOM 37V A71G0UH	1EM021654
S4	SET BAG A71G0UH	1EM322544
S5	SERIAL NO. LABEL L9750UA	-----
S6	STAND SHEET A71G0UH	1EM424484
S9	HOLD PAD A71G0UH	1EM424288A
S12	CARTON (U) A74G0UH	1EM322603
S13	CARTON (L) A71G0UH	1EM322556
S15	STAND HOLD PAD A71G0UH	1EM322720
ACCESSORIES		
X1	BAG POLYETHYLENE 235X365XT0.03	0EM408420A
X2 ▲	OWNERS MANUAL A74G0UH A74G0UH	1EMN22186
X3	REMOTE CONTROL NF018UD 192/ ECNLC5D1/NF018UD	NF018UD
X4	DRY BATTERY(SUNRISE) R6SSE/2S	XB0M451MS002
X9	QUICK SETUP GUIDE A74FOUH	1EMN22188

ELECTRICAL PARTS LIST

PRODUCT SAFETY NOTE: Products marked with a  have special characteristics important to safety. Before replacing any of these components, read carefully the product safety notice in this service manual. Don't degrade the safety of the product through improper servicing.

NOTES:

- Parts that are not assigned part numbers (-----) are not available.
- Tolerance of Capacitors and Resistors are noted with the following symbols.

C.....±0.25% D.....±0.5% F.....±1%
 G.....±2% J.....±5% K.....±10%
 M.....±20% N.....±30% Z.....+80/-20%

LCD MODULE ASSEMBLY

*VCOM Adjustment and White Balance Adjustment are required when repairing T-CON CBA.

Ref. No.	Description	Part No.
	LCD MODULE ASSEMBLY Consists of the following	UF370XA
	T-CON CBA CELL ACF ASSEMBLY BACKLIGHT ASSEMBLY	1FSA10266 ----- -----

DIGITAL MAIN CBA UNIT

Ref. No.	Description	Part No.
	DIGITAL MAIN CBA UNIT	1ESA14383

DVD MAIN CBA UNIT

Ref. No.	Description	Part No.
	DVD MAIN CBA UNIT	N7ETAKUN

MPS CBA

Ref. No.	Description	Part No.
	MPS CBA Consists of the following	1ESA14382
	POWER SUPPLY CBA(MPS-1) FUNCTION CBA(MPS-2) IR SENSOR CBA(MPS-3) JACK CBA(MPS-4) LED CBA(MPS-5)	----- ----- ----- ----- -----

POWER SUPPLY CBA

Ref. No.	Description	Part No.
	POWER SUPPLY CBA(MPS-1) Consists of the following:	-----
CAPACITORS		
	POWER SUPPLY CBA(MPS-1)	-----
C601▲	ELECTROLYTIC CAP. 220µF/200V LX	CA2D221S6017
C602	CERAMIC CAP. R K 680pF/2KV(HR)	CCD3DKA0R681
C603	POLYESTER FILM CAP. (PB FREE) 0.0015µF/100V J	CA2A152DT018
C604	POLYESTER FILM CAP. (PB FREE) 0.027µF/100V J	CA2A273DT018

Ref. No.	Description	Part No.
C605	CERAMIC CAP.(AX) B K 0.027µF/50V	CA1J273TU011
C606	FILM CAP.(P) 0.1µF/50V J	CMA1JJS00104
C608	SAFETY CAP. 2200pF/250V	CCD2EMA0E222
C633	ELECTROLYTIC CAP. 1000µF/25V M	CE1EMZNDL102
C634	ELECTROLYTIC CAP. 4700µF/10V M P=7.5	CE1AMZNDL472
C635	CERAMIC CAP.(AX) B K 0.01µF/50V	CCA1JKT0B103
C636	CERAMIC CAP. R K 1500pF/2KV(HR)	CCD3DKA0R152
C638	ELECTROLYTIC CAP. 4700µF/10V M P=7.5	CE1AMZNDL472
C639	ELECTROLYTIC CAP. 1000µF/50V M	CE1JMZPDL102
C640	ELECTROLYTIC CAP. 22µF/50V M	CE1JMASDL220
C642	CAP ELE STD-85 4700µF 6.3V SL	CE0KMZNDL472
C643	ELECTROLYTIC CAP. 4700µF/10V M P=7.5	CE1AMZNDL472
C644	ELECTROLYTIC CAP. 1000µF/16V M	CE1CMASDL102
C647	ELECTROLYTIC CAP. 10µF/50V M	CE1JMASDL100
C648	ELECTROLYTIC CAP. 1000µF/25V M	CE1EMZNDL102
C650	ELECTROLYTIC CAP. 10µF/50V M	CE1JMASDL100
C652	ELECTROLYTIC CAP. 100µF/10V M	CE1AMASDL101
C653	ELECTROLYTIC CAP. 100µF/10V M	CE1AMASDL101
C654	ELECTROLYTIC CAP. 4700µF/10V M P=7.5	CE1AMZNDL472
C655	ELECTROLYTIC CAP. 1000µF/10V M	CE1AMASDL102
C656	CAP ELE STD-85 4700µF 6.3V SL	CE0KMZNDL472
C657	CHIP CERAMIC CAP.(1608) F Z 0.1µF/50V	CHD1JZ30F104
C658	CHIP CERAMIC CAP.(1608) F Z 0.1µF/50V	CHD1JZ30F104
C659	CHIP CERAMIC CAP.(1608) F Z 0.1µF/50V	CHD1JZ30F104
C660	CHIP CERAMIC CAP.(1608) F Z 0.1µF/50V	CHD1JZ30F104
C661	CHIP CERAMIC CAP.(1608) F Z 0.1µF/50V	CHD1JZ30F104
C662	CHIP CERAMIC CAP.(1608) F Z 0.1µF/50V	CHD1JZ30F104
C663	ELECTROLYTIC CAP. 100µF/25V M	CE1EMASDL101
C664	CAP ELE STD-85 4700µF 6.3V SL	CE0KMZNDL472
C665	CHIP CERAMIC CAP.(1608) F Z 0.1µF/50V	CHD1JZ30F104
C801	ELECTROLYTIC CAP. 100µF/16V M	CE1CMASDL101
C802	CHIP CERAMIC CAP. (1608) B K 1µF/16V	CHD1CK30B105
C803	CHIP CERAMIC CAP. (1608) B K 1µF/16V	CHD1CK30B105
C804	ELECTROLYTIC CAP. 100µF/16V M	CE1CMASDL101
C805	ELECTROLYTIC CAP. 10µF/50V M	CE1JMASDL100
C806	CHIP CERAMIC CAP.(1608) B K 0.1µF/50V	CHD1JK30B104
C807	CHIP CERAMIC CAP.(1608) B K 0.1µF/50V	CHD1JK30B104
C808	ELECTROLYTIC CAP. 3.3µF/50V M	CE1JMASDL3R3
C809	CHIP CERAMIC CAP.(1608) B K 0.1µF/50V	CHD1JK30B104
C810	CHIP CERAMIC CAP.(1608) B K 0.1µF/50V	CHD1JK30B104
C811	ELECTROLYTIC CAP. 1000µF/25V M	CE1EMZNDL102
C812	CHIP CERAMIC CAP.(1608) B K 0.1µF/50V	CHD1JK30B104
C813	CHIP CERAMIC CAP.(1608) B K 0.1µF/50V	CHD1JK30B104
C814	CHIP CERAMIC CAP.(1608) B K 0.1µF/50V	CHD1JK30B104
C815	CHIP CERAMIC CAP.(1608) B K 0.1µF/50V	CHD1JK30B104
C816	ELECTROLYTIC CAP. 10µF/50V M	CE1JMASDL100
C817	CHIP CERAMIC CAP.(1608) B K 0.1µF/50V	CHD1JK30B104
C818	CHIP CERAMIC CAP.(1608) B K 0.1µF/50V	CHD1JK30B104
C819	ELECTROLYTIC CAP. 1µF/50V M	CE1JMASDL1R0
C821	ELECTROLYTIC CAP. 4.7µF/50V M	CE1JMASDL4R7
C823	CHIP CERAMIC CAP.(1608) B K 0.1µF/50V	CHD1JK30B104
C824	CHIP CERAMIC CAP. (1608) B K 1µF/16V	CHD1CK30B105
C825	CHIP CERAMIC CAP. (1608) B K 1µF/16V	CHD1CK30B105
C826	CHIP CERAMIC CAP.(1608) B K 0.1µF/50V	CHD1JK30B104
C827	ELECTROLYTIC CAP. 4.7µF/50V M	CE1JMASDL4R7
C833	CHIP CERAMIC CAP.(1608) B K 0.1µF/50V	CHD1JK30B104
C834	ELECTROLYTIC CAP. 10µF/50V M	CE1JMASDL100
C835	ELECTROLYTIC CAP. 10µF/50V M	CE1JMASDL100
C842	CHIP CERAMIC CAP. (1608) B K 1µF/16V	CHD1CK30B105
C843	CHIP CERAMIC CAP. (1608) B K 1µF/16V	CHD1CK30B105

Ref. No.	Description	Part No.
C851	ELECTROLYTIC CAP. 10 μ F/50V M	CE1JMASDL100
C857	ELECTROLYTIC CAP. 100 μ F/16V M	CE1CMASDL101
C859	ELECTROLYTIC CAP. 47 μ F/25V M	CE1EMASDL470
C860	CHIP RES.(1608) 1/10W 0 Ω	RRXAZR5Z0000
C861	CHIP RES.(1608) 1/10W 0 Ω	RRXAZR5Z0000
C862	ELECTROLYTIC CAP. 4.7 μ F/50V M	CE1JMASDL4R7
C863	ELECTROLYTIC CAP. 4.7 μ F/50V M	CE1JMASDL4R7
C864	CHIP CERAMIC CAP.(1608) B K 0.1 μ F/50V	CHD1JK30B104
C865	CHIP CERAMIC CAP.(1608) B K 0.1 μ F/50V	CHD1JK30B104
C866	CHIP CERAMIC CAP.(1608) B K 0.1 μ F/50V	CHD1JK30B104
C867	CHIP CERAMIC CAP.(1608) B K 0.1 μ F/50V	CHD1JK30B104
C868	CHIP CERAMIC CAP.(1608) B K 2700pF/50V	CHD1JK30B272
C869	CHIP CERAMIC CAP.(1608) B K 2700pF/50V	CHD1JK30B272
C870	CHIP CERAMIC CAP.(1608) B K 0.1 μ F/50V	CHD1JK30B104
C871	CHIP CERAMIC CAP.(1608) B K 0.01 μ F/50V	CHD1JK30B103
C872	CHIP CERAMIC CAP. B K 0.068 μ F/50V	CHD1JK30B683
C873	CHIP CERAMIC CAP.(1608) B K 5600pF/50V	CHD1JK30B562
C875	ELECTROLYTIC CAP. 4.7 μ F/50V M	CE1JMASDL4R7
C876	ELECTROLYTIC CAP. 4.7 μ F/50V M	CE1JMASDL4R7
C877	CHIP CERAMIC CAP. (1608) B K 1 μ F/16V	CHD1CK30B105
C878	CHIP CERAMIC CAP. (1608) B K 1 μ F/16V	CHD1CK30B105
C880	CHIP CERAMIC CAP. (1608) B K 1 μ F/16V	CHD1CK30B105
C1602	ELECTROLYTIC CAP. 1000 μ F/35V M	CE1GMZADL102
C1603	CERAMIC CAP.(AX) B K 0.01 μ F/50V	CCA1JKT0B103
C1604	ELECTROLYTIC CAP. 47 μ F/25V M	CE1EMASDL470
C1605	ELECTROLYTIC CAP. 47 μ F/25V M	CE1EMASDL470
C1606	ELECTROLYTIC CAP. 1000 μ F/6.3V M	CE0KMASDL102
C1607	ELECTROLYTIC CAP. 220 μ F/6.3V M	CE0KMASDL471
C1608	ELECTROLYTIC CAP. 470 μ F/10V M	CE1AMASDL221
CONNECTORS		
CN101B	PH CONNECTOR TOP 8P B8B-PH-K-S (LF)(SN)	J3PHC08JG029
CN201	CONNECTOR FMN TOP 13P 13FMN-BTK-A(LF)(SN)	JCFNG13JG019
CN202	CONNECTOR PRINT MES 26FMN-BTK-A(LF)(SN)	JCFNG26JG019
CN301	TWG CONNECTOR 23P TWG-P23P-A1	J3TWA23TG001
CN302	TWG CONNECTOR 23P TWG-P23P-A1	J3TWA23TG001
CN303	TWG CONNECTOR 23P TWG-P23P-A1	J3TWA23TG001
CN601	WIRE ASSEMBLY 004 3PIN / 145MM / AWG18	WX1A71G0-004
CN801	CONNECTOR BASE 2P(EH) B 2B-EH-A(LF)(SN)	J3EHC02JG010
CN802	CONNECTOR BASE 2P(EH) B 2B-EH-A(LF)(SN)	J3EHC02JG010
DIODES		
D602▲	ZENER DIODE MTZJT-7739B	QDTB00MTZJ39
D603	SWITCHING DIODE 1SS133(T-77)	QDTZ001SS133
D604▲	ZENER DIODE MTZJT-7727B	QDTB00MTZJ27
D606	ZENER DIODE MTZJT-774.3B	QDTB00MTZJ4R3
D607	SWITCHING DIODE 1SS133(T-77)	QDTZ001SS133
D611	SWITCHING DIODE 1SS133(T-77)	QDTZ001SS133
D612	SWITCHING DIODE 1SS133(T-77)	QDTZ001SS133
D613	PCB JUMPER D0.6-P5.0	JW5.0T
D631	ZENER DIODE MTZJT-775.6B	QDTB00MTZJ5R6
D632	SCHOTTKY BARRIER DIODE ERB81-004	AERB81004***
D633	RECTIFIER DIODE FR202-B/P	NDQZ000FR202
D635	ZENER DIODE MTZJT-7718B	QDTB00MTZJ18
D636	RECTIFIER DIODE FR202-B/P	NDQZ000FR202
D637	SCHOTTKY BARRIER DIODE SB240-B/P	NDQZ000SB240
D640	SCHOTTKY BARRIER DIODE SB240-B/P	NDQZ000SB240
D642	SWITCHING DIODE 1SS133(T-77)	QDTZ001SS133
D643	ZENER DIODE MTZJT-7712B	QDTB00MTZJ12
D644	DIODE 1ZC43(Q)	QDLZ001ZC43Q
D646	ZENER DIODE MTZJT-7718B	QDTB00MTZJ18

Ref. No.	Description	Part No.
D647	SCHOTTKY BARRIER DIODE SB240-B/P	NDQZ000SB240
D649	ZENER DIODE MTZJT-7733B	QDTB00MTZJ33
D650	ZENER DIODE MTZJT-776.2B	QDTB00MTZJ6R2
D651	DIODE FR104-B	NDLZ000FR104
D652	PCB JUMPER D0.6-P5.0	JW5.0T
D654	SCHOTTKY BARRIER DIODE SB140	NDWZ000SB140
D655	DIODE FR104-B	NDLZ000FR104
D656	PCB JUMPER D0.6-P5.0	JW5.0T
D657	ZENER DIODE MTZJT-776.8B	QDTB00MTZJ6R8
D658	ZENER DIODE MTZJT-775.1B	QDTB00MTZJ5R1
D659	ZENER DIODE MTZJT-7716B	QDTB00MTZJ16
D660	ZENER DIODE MTZJT-776.8B	QDTB00MTZJ6R8
D661	SWITCHING DIODE 1SS133(T-77)	QDTZ001SS133
D663	SWITCHING DIODE 1SS133(T-77)	QDTZ001SS133
D664	SWITCHING DIODE 1SS133(T-77)	QDTZ001SS133
D665	SWITCHING DIODE 1SS133(T-77)	QDTZ001SS133
D666	SWITCHING DIODE 1SS133(T-77)	QDTZ001SS133
D667	SCHOTTKY BARRIER DIODE SB140	NDWZ000SB140
D668	PCB JUMPER D0.6-P5.0	JW5.0T
D670	SWITCHING DIODE 1SS133(T-77)	QDTZ001SS133
D671	SWITCHING DIODE 1SS133(T-77)	QDTZ001SS133
D672	ZENER DIODE MTZJT-7716B	QDTB00MTZJ16
D674	SWITCHING DIODE 1SS133(T-77)	QDTZ001SS133
D675	ZENER DIODE MTZJT-7710B	QDTB00MTZJ10
D676	SWITCHING DIODE 1SS133(T-77)	QDTZ001SS133
D677	SWITCHING DIODE 1SS133(T-77)	QDTZ001SS133
D801	ZENER DIODE MTZJT-7710B	QDTB00MTZJ10
D802	SWITCHING DIODE 1SS133(T-77)	QDTZ001SS133
D803	PCB JUMPER D0.6-P5.0	JW5.0T
D810	SWITCHING DIODE 1SS133(T-77)	QDTZ001SS133
D811	SWITCHING DIODE 1SS133(T-77)	QDTZ001SS133
D851	SWITCHING DIODE 1SS133(T-77)	QDTZ001SS133
D852	SWITCHING DIODE 1SS133(T-77)	QDTZ001SS133
D853	ZENER DIODE EDZTE61 5.6B	QD1B00EDZ5R6
D854	ZENER DIODE EDZTE61 5.6B	QD1B00EDZ5R6
D1601	DIODE SCHOTTKY ERC84-009L	QD4ZERC84009
D1602	RECTIFIER DIODE 1N4005	NDQZ001N4005
D1603	RECTIFIER DIODE 1N4005	NDQZ001N4005
D1604	SWITCHING DIODE 1SS133(T-77)	QDTZ001SS133
D1605	RECTIFIER DIODE 1N4005	NDQZ001N4005
D1606	RECTIFIER DIODE 1N4005	NDQZ001N4005
D1607	DIODE SCHOTTKY ERC84-009L	QD4ZERC84009
D1610	SWITCHING DIODE 1SS133(T-77)	QDTZ001SS133
ICS		
IC603▲	PHOTO COUPLER LTV817MCF	NPECLTV817MF
IC637	IC LD1117V	NSZBA0SSS046
IC801	IC POWER AMP BD5422EFS-E2	QSZBA0TRM113
IC802	IC SURROUND PROCESSOR LV1115M-TLM-E MFP24S	QSZBA0TSY050
IC1601	IC LD1117V	NSZBA0SSS046
IC1602	IC SHUNT REGULATOR KIA431-AT/P	NSZBA0TJY036
IC1603	IC SHUNT REGULATOR KIA431-AT/P	NSZBA0TJY036
COILS		
L661	CHOKE COIL 22 μ H-K	LLBD00PKV021
L801	COIL RADIAL LHLP10NB330M 33 μ H	LLF3300TU003
L802	COIL RADIAL LHLP10NB330M 33 μ H	LLF3300TU003
L803	COIL RADIAL LHLP10NB330M 33 μ H	LLF3300TU003
L804	COIL RADIAL LHLP10NB330M 33 μ H	LLF3300TU003
L805	INDUCTOR 22 μ H-K-5FT	LLARKBSTU220
L852	INDUCTOR 100 μ H-K-5FT	LLARKBSTU101
TRANSISTORS		
Q102	TRANSISTOR KTA1267-GR-AT/P	NQS1KTA1267P
Q601▲	FET MOS 2SK3561(Q) IDSS100UA	QFWZ2SK3561Q

Ref. No.	Description	Part No.
Q602▲	TRANSISTOR 2SC2120-Q(TE2 F T)	QQS02SC2120F
Q631	TRANSISTOR KTC3199-GR-AT/P	NQS4KTC3199P
Q632▲	PNP TRANSISTOR POWER 2SA1887(F)	QQWZ2SA1887F
Q633	TRANSISTOR KTC3199-GR-AT/P	NQS4KTC3199P
Q635	TRANSISTOR KTA1267-GR-AT/P	NQS1KTA1267P
Q636	TRANSISTOR KTC3199-GR-AT/P	NQS4KTC3199P
Q637	PNP TRANSISTOR POWER 2SA1887(F)	QQWZ2SA1887F
Q638▲	TRANSISTOR(PB FREE) KTC2026-Y/P	NQEYKTC2026P
Q639	TRANSISTOR 2SC2120-Y(TE2 F T)	QQSY2SC2120F
Q640	PNP TRANSISTOR POWER 2SA1887(F)	QQWZ2SA1887F
Q641	TRANSISTOR 2SC2120-Y(TE2 F T)	QQSY2SC2120F
Q643	TRANSISTOR KTC3199-GR-AT/P	NQS4KTC3199P
Q644	TRANSISTOR KTC3199-GR-AT/P	NQS4KTC3199P
Q650	TRANSISTOR(PB FREE) KTC2026-Y/P	NQEYKTC2026P
Q651	TRANSISTOR KTA1267-GR-AT/P	NQS1KTA1267P
Q652	TRANSISTOR KTC3199-GR-AT/P	NQS4KTC3199P
Q801	TRANSISTOR(PB FREE) KTC2026-Y/P	NQEYKTC2026P
Q802	TRANSISTOR KTC3199-GR-AT/P	NQS4KTC3199P
Q1601	TRANSISTOR KTA1281-Y-AT/P	NQVYKTA1281P
Q1602	TRANSISTOR KTC3199-GR-AT/P	NQS4KTC3199P
Q1603	TRANSISTOR 2SD400(F)	QQUF002SD400
Q1604	TRANSISTOR KTC3199-GR-AT/P	NQS4KTC3199P
RESISTORS		
R109	CARBON RES. 1/4W J 10k Ω	RCX4JATZ0103
R129	CHIP RES. 1/10W J 10k Ω	RRXAJR5Z0103
R139	CHIP RES. 1/10W J 100 Ω	RRXAJR5Z0101
R140	CHIP RES. 1/10W J 100 Ω	RRXAJR5Z0101
R601▲	METAL RES. 3W J 0.33 Ω	RN03JZPZ0R33
R603	CARBON RES. 1/4W J 1.8k Ω	RCX4JATZ0182
R604	CARBON RES. 1/4W J 390k Ω	RCX4JATZ0394
R605	CARBON RES. 1/4W J 390k Ω	RCX4JATZ0394
R606	CARBON RES. 1/4W J 390k Ω	RCX4JATZ0394
R607	CARBON RES. 1/4W J 390k Ω	RCX4JATZ0394
R608	PCB JUMPER D0.6-P5.0	JW5.0T
R609	CARBON RES. 1/4W J 2.2k Ω	RCX4JATZ0222
R610	CARBON RES. 1/4W J 220 Ω	RCX4JATZ0221
R611	CARBON RES. 1/4W J 820 Ω	RCX4JATZ0821
R612	CARBON RES. 1/4W J 220 Ω	RCX4JATZ0221
R613	CARBON RES. 1/4W J 180 Ω	RCX4JATZ0181
R615	CHIP RES. 1/10W J 10k Ω	RRXAJR5Z0103
R616	CARBON RES. 1/4W J 1.2k Ω	RCX4JATZ0122
R617	CARBON RES. 1/4W J 1.2k Ω	RCX4JATZ0122
R618	METAL OXIDE FILM RES. 2W J 10 Ω	RN02100ZU001
R619	METAL OXIDE FILM RES. 2W J 10 Ω	RN02100ZU001
R620	METAL OXIDE FILM RES. 2W J 1 Ω	RN021R0DP004
R621	CHIP RES. 1/10W J 10k Ω	RRXAJR5Z0103
R622	CARBON RES. 1/4W J 560 Ω	RCX4JATZ0561
R633	CARBON RES. 1/4W J 820 Ω	RCX4JATZ0821
R634	CARBON RES. 1/4W J 10k Ω	RCX4JATZ0103
R635	CARBON RES. 1/4W J 560 Ω	RCX4JATZ0561
R636	CARBON RES. 1/4W J 1k Ω	RCX4JATZ0102
R639	CHIP RES. 1/10W J 560 Ω	RRXAJR5Z0561
R641	CARBON RES. 1/4W J 1.2k Ω	RCX4JATZ0122
R642	CARBON RES. 1/4W J 2.7k Ω	RCX4JATZ0272
R644	PCB JUMPER D0.6-P5.0	JW5.0T
R645	CARBON RES. 1/4W J 12k Ω	RCX4JATZ0123
R646	CARBON RES. 1/4W J 15k Ω	RCX4JATZ0153
R649	METAL OXIDE FILM RES. 1W 470 Ω	RN01471DP003
R650	CARBON RES. 1/4W J 10k Ω	RCX4JATZ0103
R651	CARBON RES. 1/4W J 100 Ω	RCX4JATZ0101
R652	CARBON RES. 1/4W J 180 Ω	RCX4JATZ0181
R653	CARBON RES. 1/4W J 180 Ω	RCX4JATZ0181

Ref. No.	Description	Part No.
R654	CARBON RES. 1/4W J 4.7k Ω	RCX4JATZ0472
R655	CHIP RES. 1/10W F 1.0k Ω	RRXAFR5H1001
R656	CARBON RES. 1/4W J 4.7k Ω	RCX4JATZ0472
R657	CHIP RES. 1/10W J 10k Ω	RRXAJR5Z0103
R658	CHIP RES. 1/10W F 620 Ω	RRXAFR5H6200
R659	CARBON RES. 1/4W J 180 Ω	RCX4JATZ0181
R660	CHIP RES. 1/10W J 10k Ω	RRXAJR5Z0103
R661	CARBON RES. 1/4W J 4.7k Ω	RCX4JATZ0472
R662	CARBON RES. 1/4W J 4.7k Ω	RCX4JATZ0472
R663	CHIP RES. 1/10W J 10k Ω	RRXAJR5Z0103
R664	CHIP RES. 1/10W F 6.8k Ω	RRXAFR5H6801
R665	CHIP RES. 1/10W J 2.2k Ω	RRXAJR5Z0222
R666	CHIP RES. 1/10W F 12k Ω	RRXAFR5H1202
R667	CHIP RES. 1/10W F 82.0 k Ω	RRXAFR5H8202
R668	CHIP RES. 1/10W J 3.3k Ω	RRXAJR5Z0332
R669	CHIP RES. 1/10W J 47k Ω	RRXAJR5Z0473
R670	CHIP RES. 1/10W J 10k Ω	RRXAJR5Z0103
R671	CARBON RES. 1/4W J 4.7k Ω	RCX4JATZ0472
R672	CARBON RES. 1/4W J 1.8k Ω	RCX4JATZ0182
R673	CARBON RES. 1/4W J 1.8k Ω	RCX4JATZ0182
R675	METAL OXIDE FILM RES. 2W J 1 Ω	RN021R0DP004
R676	CHIP RES. 1/10W J 2.2k Ω	RRXAJR5Z0222
R677	CHIP RES. 1/10W J 2.2k Ω	RRXAJR5Z0222
R678	CHIP RES. 1/10W J 6.8k Ω	RRXAJR5Z0682
R679	CHIP RES. 1/10W J 22k Ω	RRXAJR5Z0223
R680	CHIP RES. 1/10W J 22k Ω	RRXAJR5Z0223
R681	CHIP RES. 1/10W J 22k Ω	RRXAJR5Z0223
R682	CHIP RES. 1/10W J 100k Ω	RRXAJR5Z0104
R683	CARBON RES. 1/4W J 22k Ω	RCX4JATZ0223
R684	CHIP RES. 1/10W J 56k Ω	RRXAJR5Z0563
R685	CHIP RES. 1/10W J 22k Ω	RRXAJR5Z0223
R687	CARBON RES. 1/4W J 4.7k Ω	RCX4JATZ0472
R688	CARBON RES. 1/4W J 100k Ω	RCX4JATZ0104
R689	CARBON RES. 1/4W J 10k Ω	RCX4JATZ0103
R690	CHIP RES. 1/10W J 10k Ω	RRXAJR5Z0103
R691	CARBON RES. 1/4W J 1.2k Ω	RCX4JATZ0122
R692	CARBON RES. 1/4W J 33k Ω	RCX4JATZ0333
R693	CHIP RES. 1/10W J 3.3k Ω	RRXAJR5Z0332
R694	CARBON RES. 1/4W J 560 Ω	RCX4JATZ0561
R695	CARBON RES. 1/4W J 560 Ω	RCX4JATZ0561
R696	CHIP RES. 1/10W J 56k Ω	RRXAJR5Z0563
R800	PCB JUMPER D0.6-P12.5	JW12.5T
R801	CHIP RES. 1/10W F 100k Ω	RRXAFR5H1003
R802	CHIP RES. 1/10W J 390k Ω	RRXAJR5Z0394
R803	CARBON RES. 1/4W J 10 Ω	RCX4JATZ0100
R804	CARBON RES. 1/4W J 1k Ω	RCX4JATZ0102
R805	CARBON RES. 1/4W J 6.8k Ω	RCX4JATZ0682
R806	CHIP RES. 1/10W J 3.3k Ω	RRXAJR5Z0332
R807	CHIP RES. 1/10W J 22k Ω	RRXAJR5Z0223
R808	CHIP RES. 1/10W F 24k Ω	RRXAFR5H2402
R809	CHIP RES. 1/10W J 10k Ω	RRXAJR5Z0103
R810	CHIP RES. 1/10W F 24k Ω	RRXAFR5H2402
R812	CHIP RES. 1/10W J 270k Ω	RRXAJR5Z0274
R813	CHIP RES. 1/10W F 100k Ω	RRXAFR5H1003
R814	CHIP RES. 1/10W J 10k Ω	RRXAJR5Z0103
R815	CHIP RES.(1608) 1/10W 0 Ω	RRXAZR5Z0000
R816	CHIP RES. 1/10W J 100 Ω	RRXAJR5Z0101
R817	CHIP RES. 1/10W J 4.7k Ω	RRXAJR5Z0472
R819	CHIP RES. 1/10W J 2.7k Ω	RRXAJR5Z0272
R820	CHIP RES. 1/10W J 10k Ω	RRXAJR5Z0103
R854	CARBON RES. 1/4W J 100 Ω	RCX4JATZ0101
R855	CHIP RES. 1/10W J 2.2k Ω	RRXAJR5Z0222
R856	CARBON RES. 1/4W J 3.3k Ω	RCX4JATZ0332

Ref. No.	Description	Part No.
R859	CHIP RES. 1/10W J 10 Ω	RRXAJR5Z0100
R860	CHIP RES. 1/10W J 5.1k Ω	RRXAJR5Z0512
R863	CHIP RES. 1/10W J 3.6k Ω	RRXAJR5Z0362
R864	CHIP RES. 1/10W J 3.6k Ω	RRXAJR5Z0362
R865	CHIP RES. 1/10W J 2.2k Ω	RRXAJR5Z0222
R866	CHIP RES. 1/10W J 2.2k Ω	RRXAJR5Z0222
R869	CHIP RES.(1608) 1/10W 0 Ω	RRXAZR5Z0000
R870	CHIP RES.(1608) 1/10W 0 Ω	RRXAZR5Z0000
R1601	CARBON RES. 1/4W J 10k Ω	RCX4JATZ0103
R1602	CARBON RES. 1/4W J 390 Ω	RCX4JATZ0391
R1603	CHIP RES. 1/10W J 10k Ω	RRXAJR5Z0103
R1604	CHIP RES. 1/10W J 10k Ω	RRXAJR5Z0103
R1605	METAL OXIDE FILM RES. 1W J 6.8 Ω	RN016R8ZU001
R1606	CARBON RES. 1/4W J 2.2 Ω	RCX4JATZ02R2
R1607	CHIP RES. 1/10W J 1k Ω	RRXAJR5Z0102
R1608	RES CHIP.(1608) 1/10W J 0.30 Ω	RRXAR30HH007
R1609	RES CHIP.(1608) 1/10W J 0.30 Ω	RRXAR30HH007
R1610	CARBON RES. 1/4W J 18 Ω	RCX4JATZ0180
R1611	CARBON RES. 1/4W J 18 Ω	RCX4JATZ0180
R1612	CHIP RES. 1/10W J 470 Ω	RRXAJR5Z0471
R1613	CHIP RES. 1/10W F 3.3k Ω	RRXAFR5H3301
R1614	CHIP RES. 1/10W F 10k Ω	RRXAFR5H1002
R1615	CARBON RES. 1/4W J 18 Ω	RCX4JATZ0180
R1616	CARBON RES. 1/4W J 12 Ω	RCX4JATZ0120
R1617	CARBON RES. 1/4W J 470 Ω	RCX4JATZ0471
R1618	CHIP RES. 1/10W F 3.3k Ω	RRXAFR5H3301
R1619	CHIP RES. 1/10W F 10k Ω	RRXAFR5H1002
R1621	CHIP RES. 1/10W J 6.8k Ω	RRXAJR5Z0682
R1622	CHIP RES. 1/10W J 3.3k Ω	RRXAJR5Z0332
R1626	CARBON RES. 1/4W J 1.5k Ω	RCX4JATZ0152

MISCELLANEOUS

B10	HEAT SINK PKH ASSEMBLY L3201UB	1EM420648
B11	HEAT SINK PKP ASSEMBLY L4200EA	1EM420855
B38	HEAT SINK PMM A74F0UH	1EM424517
BC601	PCB JUMPER D0.6-P5.0	JW5.0T
BC602	BEADS INDUCTOR FBR07HA121SB-00	LLBF00STU030
BC631	PCB JUMPER D0.6-P5.0	JW5.0T
BC632	PCB JUMPER D0.6-P5.0	JW5.0T
BC633	BEADS INDUCTOR FBR07HA121SB-00	LLBF00STU030
BC634	BEADS INDUCTOR FBR07HA121SB-00	LLBF00STU030
BC635	BEADS INDUCTOR FBR07HA121SB-00	LLBF00STU030
BC1602	PCB JUMPER D0.6-P5.0	JW5.0T
JS612	PCB JUMPER D0.6-P7.5	JW7.5T
JS632	PCB JUMPER D0.6-P15.0	JW15.0T
JS641	PCB JUMPER D0.6-P5.0	JW5.0T
JS642	PCB JUMPER D0.6-P5.0	JW5.0T
JS802	PCB JUMPER D0.6-P5.0	JW5.0T
JS803	PCB JUMPER D0.6-P5.0	JW5.0T
L6	SCREW B-TIGHT D3X8 BIND HEAD+	GBJB3080
T601▲	TRANS POWER 7711	LTT3PC0KT025

FUNCTION CBA

Ref. No.	Description	Part No.
	FUNCTION CBA(MPS-2) Consists of the following:	-----
CONNECTOR		
CN102	CONNECTOR PRINT OSU S6B-PH-K-S(LF)(SN)	J3PHC06JG030
DIODES		
D104	ZENER DIODE MTZJT-775.6B	QDTB0MTZJ5R6
D108	ZENER DIODE MTZJT-775.6B	QDTB0MTZJ5R6

Ref. No.	Description	Part No.
RESISTORS		
R114	CHIP RES. 1/10W F 2.7k Ω	RRXAFR5H2701
R115	CHIP RES. 1/10W F 2.2k Ω	RRXAFR5H2201
R116	CHIP RES. 1/10W F 1.5k Ω	RRXAFR5H1501
R117	CHIP RES. 1/10W F 1.5k Ω	RRXAFR5H1501
R118	PCB JUMPER D0.6-P5.0	JW5.0T
R120	CHIP RES. 1/10W F 6.8k Ω	RRXAFR5H6801
R121	CHIP RES. 1/10W F 4.7k Ω	RRXAFR5H4701
R122	CHIP RES. 1/10W F 2.7k Ω	RRXAFR5H2701
R123	CHIP RES. 1/10W F 2.2k Ω	RRXAFR5H2201
R124	CHIP RES. 1/10W F 1.5k Ω	RRXAFR5H1501
R125	CARBON RES. 1/4W J 220 Ω	RCX4JATZ0221
R126	CHIP RES. 1/10W F 1.5k Ω	RRXAFR5H1501
SWITCHES		
SW103	TACT SWITCH SKQSAB	SST0101AL038
SW104	TACT SWITCH SKQSAB	SST0101AL038
SW105	TACT SWITCH SKQSAB	SST0101AL038
SW106	TACT SWITCH SKQSAB	SST0101AL038
SW108	TACT SWITCH SKQSAB	SST0101AL038
SW109	TACT SWITCH SKQSAB	SST0101AL038
SW110	TACT SWITCH SKQSAB	SST0101AL038
SW111	TACT SWITCH SKQSAB	SST0101AL038
SW112	TACT SWITCH SKQSAB	SST0101AL038
SW113	TACT SWITCH SKQSAB	SST0101AL038
SW114	TACT SWITCH SKQSAB	SST0101AL038
MISCELLANEOUS		
BC102	PCB JUMPER D0.6-P5.0	JW5.0T
JS101	PCB JUMPER D0.6-P5.0	JW5.0T
JS103	PCB JUMPER D0.6-P5.0	JW5.0T

IR SENSOR CBA

Ref. No.	Description	Part No.
	IR SENSOR CBA(MPS-3) Consists of the following:	-----
CAPACITORS		
C101	ELECTROLYTIC CAP. 47μF/16V M H7	CE1CMAVSL470
C102	CHIP CERAMIC CAP. F Z 0.01μF/50V	CHD1JZ30F103
C105	CHIP CERAMIC CAP.(1608) F Z 0.1μF/50V	CHD1JZ30F104
C106	CHIP CERAMIC CAP.(1608) F Z 0.1μF/50V	CHD1JZ30F104
C107	CHIP CERAMIC CAP.(1608) F Z 0.1μF/50V	CHD1JZ30F104
C112	CHIP CERAMIC CAP.(1608) F Z 0.1μF/50V	CHD1JZ30F104
CONNECTORS		
CN001	PH CONNECTOR SIDE 8P S8B-PH-K-S(LF)(SN)	J3PHC08JG030
CN103	PH CONNECTOR SIDE 2P S2B-PH-K-S(LF)(SN)	J3PHC02JG030
DIODES		
D101	LED L-53HT	NP4Z000L53HT
D102	LED 333GT/E	NPHZ00333GTE
RESISTORS		
R101	CHIP RES. 1/10W J 100 Ω	RRXAJR5Z0101
R102	CHIP RES. 1/10W J 3.3k Ω	RRXAJR5Z0332
R103	CHIP RES. 1/10W J 220 Ω	RRXAJR5Z0221
R104	CHIP RES. 1/10W J 220 Ω	RRXAJR5Z0221
R105	CARBON RES. 1/4W J 1k Ω	RCX4JATZ0102
R134	CHIP RES.(1608) 1/10W 0 Ω	RRXAJR5Z0000
R135	CHIP RES.(1608) 1/10W 0 Ω	RRXAJR5Z0000
SWITCH		
SW116	TACT SWITCH SKQSAB	SST0101AL038
MISCELLANEOUS		
BC101	PCB JUMPER D0.6-P5.0	JW5.0T
RCV891	PHOTO LINK MODULE KSM-712TH2E	USESJRSKK044

JACK CBA

Ref. No.	Description	Part No.
	JACK CBA(MPS-4) Consists of the following:	-----
CAPACITORS		
C7001	ELECTROLYTIC CAP. 47μF/16V M H7	CE1CMAVSL470
C7002	CHIP CERAMIC CAP.(2125) F Z 10μF/10V	CHE1AZ30F106
C7003	CHIP CERAMIC CAP.(2125) F Z 10μF/10V	CHE1AZ30F106
C7004	CHIP CERAMIC CAP. F Z 0.47μF/16V	CHD1CZ30F474
C7005	CHIP CERAMIC CAP. F Z 0.47μF/16V	CHD1CZ30F474
C7006	CHIP CERAMIC CAP. F Z 0.47μF/16V	CHD1CZ30F474
C7007	CHIP CERAMIC CAP. F Z 0.47μF/16V	CHD1CZ30F474
C7008	CHIP CERAMIC CAP.(1608) F Z 0.1μF/50V	CHD1JZ30F104
C7009	CHIP CERAMIC CAP.(1608) F Z 0.1μF/50V	CHD1JZ30F104
C7010	CHIP CERAMIC CAP.(1608) F Z 0.1μF/50V	CHD1JZ30F104
C7012	CHIP CERAMIC CAP.(1608) F Z 0.1μF/50V	CHD1JZ30F104
C7013	CHIP CERAMIC CAP.(1608) F Z 0.1μF/50V	CHD1JZ30F104
C7101	ELECTROLYTIC CAP. 220μF/6.3V M H7	CE0KMAVSL221
C7102	CERAMIC CAP.(AX) B K 1000pF/50V	CCA1JKT0B102
C7109	CHIP CERAMIC CAP. F Z 4.7μF/16V(2012)	CHE1CZ30F475
C7110	CHIP CERAMIC CAP. F Z 4.7μF/16V(2012)	CHE1CZ30F475
C7111	ELECTROLYTIC CAP. 220μF/6.3V M H7	CE0KMAVSL221
C7515	CHIP CERAMIC CAP. F Z 4.7μF/16V(2012)	CHE1CZ30F475
C7516	CHIP CERAMIC CAP. F Z 4.7μF/16V(2012)	CHE1CZ30F475
C7602	CHIP CERAMIC CAP. F Z 4.7μF/16V(2012)	CHE1CZ30F475
C7605	CHIP CERAMIC CAP. F Z 4.7μF/16V(2012)	CHE1CZ30F475
C7608	CHIP CERAMIC CAP. F Z 4.7μF/16V(2012)	CHE1CZ30F475
C7611	CHIP CERAMIC CAP. F Z 4.7μF/16V(2012)	CHE1CZ30F475
C7615	CHIP CERAMIC CAP. F Z 4.7μF/16V(2012)	CHE1CZ30F475
C7618	CHIP CERAMIC CAP. F Z 4.7μF/16V(2012)	CHE1CZ30F475
C7621	CHIP CERAMIC CAP. F Z 4.7μF/16V(2012)	CHE1CZ30F475
C7624	CHIP CERAMIC CAP. F Z 4.7μF/16V(2012)	CHE1CZ30F475
C7701	CHIP CERAMIC CAP.(1608) CH J 100pF/50V	CHD1JJ3CH101
C7702	CHIP CERAMIC CAP. F Z 0.47μF/16V	CHD1CZ30F474
C7705	CHIP CERAMIC CAP.(1608) CH J 100pF/50V	CHD1JJ3CH101
C7706	CHIP CERAMIC CAP. F Z 0.47μF/16V	CHD1CZ30F474
C7709	CHIP CERAMIC CAP.(1608) CH J 100pF/50V	CHD1JJ3CH101
C7710	CHIP CERAMIC CAP. F Z 0.47μF/16V	CHD1CZ30F474
C7714	CHIP CERAMIC CAP.(1608) CH J 100pF/50V	CHD1JJ3CH101
C7715	CHIP CERAMIC CAP.(1608) B K 0.047μF/50V	CHD1JK30B473
C7718	CHIP CERAMIC CAP.(1608) CH J 100pF/50V	CHD1JJ3CH101
C7719	CHIP CERAMIC CAP. F Z 0.47μF/16V	CHD1CZ30F474
C7723	CHIP CERAMIC CAP.(1608) CH J 100pF/50V	CHD1JJ3CH101
C7724	CHIP CERAMIC CAP.(1608) B K 0.047μF/50V	CHD1JK30B473
C7729	CHIP CERAMIC CAP. CH J 39pF/50V	CHD1JJ3CH390
C7730	CHIP CERAMIC CAP. F Z 0.47μF/16V	CHD1CZ30F474
C7733	CHIP CERAMIC CAP. CH J 39pF/50V	CHD1JJ3CH390
C7734	CHIP CERAMIC CAP. F Z 0.47μF/16V	CHD1CZ30F474
C7738	CHIP CERAMIC CAP. CH J 39pF/50V	CHD1JJ3CH390
C7739	CHIP CERAMIC CAP. F Z 0.47μF/16V	CHD1CZ30F474
C7743	CHIP CERAMIC CAP. CH J 39pF/50V	CHD1JJ3CH390
C7744	CHIP CERAMIC CAP. F Z 0.47μF/16V	CHD1CZ30F474
C7747	CHIP CERAMIC CAP. CH J 39pF/50V	CHD1JJ3CH390
C7748	CHIP CERAMIC CAP. F Z 0.47μF/16V	CHD1CZ30F474
C7751	CHIP CERAMIC CAP. CH J 39pF/50V	CHD1JJ3CH390
C7752	CHIP CERAMIC CAP. F Z 0.47μF/16V	CHD1CZ30F474
C7801	ELECTROLYTIC CAP. 100μF/16V M H7	CE1CMAVSL101
C7802	ELECTROLYTIC CAP. 100μF/16V M H7	CE1CMAVSL101
CONNECTOR		
CN7501	FMN CONNECTOR TOP 24P 24FMN-BTK-A(LF)(SN)	JCFNG24JG019
DIODE		
D7001	ZENER DIODE EDZTE61 5.6B	QD1B00EDZ5R6

Ref. No.	Description	Part No.
IC		
IC7001	IC VIDEO ANALOG INTERFACE R2A11011FP QFP 56PIN	QSZBA0RHT066
COILS		
L7802	PCB JUMPER D0.6-P5.0	JW5.0T
L7803	PCB JUMPER D0.6-P5.0	JW5.0T
RESISTORS		
R7001	CHIP RES. 1/10W J 10k Ω	RRXAJR5Z0103
R7002	CHIP RES. 1/10W J 10k Ω	RRXAJR5Z0103
R7101	CHIP RES. 1/10W J 75 Ω	RRXAJR5Z0750
R7102	CHIP RES. 1/10W J 75 Ω	RRXAJR5Z0750
R7103	CHIP RES. 1/10W J 75 Ω	RRXAJR5Z0750
R7104	CHIP RES. 1/10W J 75 Ω	RRXAJR5Z0750
R7105	CHIP RES.(1608) 1/10W 0 Ω	RRXAJR5Z0000
R7106	CHIP RES.(1608) 1/10W 0 Ω	RRXAJR5Z0000
R7111	CHIP RES. 1/10W J 75 Ω	RRXAJR5Z0750
R7112	CHIP RES. 1/10W J 75 Ω	RRXAJR5Z0750
R7502	PCB JUMPER D0.6-P5.0	JW5.0T
R7503	PCB JUMPER D0.6-P5.0	JW5.0T
R7504	PCB JUMPER D0.6-P5.0	JW5.0T
R7515	CHIP RES. 1/10W J 18k Ω	RRXAJR5Z0183
R7516	CHIP RES. 1/10W J 18k Ω	RRXAJR5Z0183
R7517	CHIP RES. 1/10W J 100k Ω	RRXAJR5Z0104
R7518	CHIP RES. 1/10W J 100k Ω	RRXAJR5Z0104
R7601	CHIP RES. 1/10W J 43k Ω	RRXAJR5Z0433
R7602	CHIP RES. 1/10W J 27k Ω	RRXAJR5Z0273
R7604	CHIP RES. 1/10W J 43k Ω	RRXAJR5Z0433
R7605	CHIP RES. 1/10W J 27k Ω	RRXAJR5Z0273
R7607	CHIP RES. 1/10W J 43k Ω	RRXAJR5Z0433
R7608	CHIP RES. 1/10W J 27k Ω	RRXAJR5Z0273
R7610	CHIP RES. 1/10W J 43k Ω	RRXAJR5Z0433
R7611	CHIP RES. 1/10W J 27k Ω	RRXAJR5Z0273
R7613	CHIP RES. 1/10W J 43k Ω	RRXAJR5Z0433
R7614	CHIP RES. 1/10W J 27k Ω	RRXAJR5Z0273
R7616	CHIP RES. 1/10W J 43k Ω	RRXAJR5Z0433
R7617	CHIP RES. 1/10W J 27k Ω	RRXAJR5Z0273
R7619	CHIP RES. 1/10W J 43k Ω	RRXAJR5Z0433
R7620	CHIP RES. 1/10W J 27k Ω	RRXAJR5Z0273
R7622	CHIP RES. 1/10W J 43k Ω	RRXAJR5Z0433
R7623	CHIP RES. 1/10W J 27k Ω	RRXAJR5Z0273
R7701	CHIP RES. 1/10W J 75 Ω	RRXAJR5Z0750
R7702	CHIP RES. 1/10W J 100 Ω	RRXAJR5Z0101
R7708	CHIP RES. 1/10W J 75 Ω	RRXAJR5Z0750
R7709	CHIP RES. 1/10W J 100 Ω	RRXAJR5Z0101
R7715	CHIP RES. 1/10W J 75 Ω	RRXAJR5Z0750
R7716	CHIP RES. 1/10W J 100 Ω	RRXAJR5Z0101
R7723	CHIP RES. 1/10W J 75 Ω	RRXAJR5Z0750
R7724	CHIP RES. 1/10W J 100 Ω	RRXAJR5Z0101
R7730	CHIP RES. 1/10W J 75 Ω	RRXAJR5Z0750
R7731	CHIP RES. 1/10W J 100 Ω	RRXAJR5Z0101
R7738	CHIP RES. 1/10W J 75 Ω	RRXAJR5Z0750
R7739	CHIP RES. 1/10W J 100 Ω	RRXAJR5Z0101
R7747	CHIP RES.(1608) 1/10W F 75 Ω	RRXAFR5H75R0
R7748	CHIP RES. 1/10W J 100 Ω	RRXAJR5Z0101
R7755	CHIP RES.(1608) 1/10W F 75 Ω	RRXAFR5H75R0
R7756	CHIP RES. 1/10W J 100 Ω	RRXAJR5Z0101
R7763	CHIP RES.(1608) 1/10W F 75 Ω	RRXAFR5H75R0
R7764	CHIP RES. 1/10W J 100 Ω	RRXAJR5Z0101
R7771	CHIP RES.(1608) 1/10W F 75 Ω	RRXAFR5H75R0
R7772	CHIP RES. 1/10W J 100 Ω	RRXAJR5Z0101
R7779	CHIP RES.(1608) 1/10W F 75 Ω	RRXAFR5H75R0
R7780	CHIP RES. 1/10W J 100 Ω	RRXAJR5Z0101
R7787	CHIP RES.(1608) 1/10W F 75 Ω	RRXAFR5H75R0

Ref. No.	Description	Part No.
R7788	CHIP RES. 1/10W J 100 Ω	RRXAJR5Z0101
MISCELLANEOUS		
JK7501	JACK HPEP SML PCB S PJ-358H	JXSJ020YUQ01
JK7701	JACK SW DIN PCB S YKF51-5379V	JYEJ040JC002
JK7702	JACK SW RCA PCB S RCA-347HDT-02	JYRJ030YUQ01
JK7705	JACK SW DIN PCB L DIN-435C	JYEL040YUQ02
JK7706	JACK SW RCA PCB L 05 RCA-340NI-01	JYRL030YUQ14
JK7711	JACK RCA PCB S 03 RCA-347HT-03	JXRJ030YUQ01
JK7712	JACK SW RCA PCB S RCA-228H(2)NI-01	JYRJ020YUQ02
JK7713	JACK RCA PCB S 03 RCA-347HT-03	JXRJ030YUQ01
JK7714	JACK SW RCA PCB S RCA-228H(2)NI-01	JYRJ020YUQ02

LED CBA

Ref. No.	Description	Part No.
	LED CBA(MPS-5) Consists of the following:	-----
CAPACITOR		
C111	CHIP CERAMIC CAP.(1608) F Z 0.1μF/50V	CHD1JZ30F104
CONNECTOR		
CN104	WIRE ASSEMBLY 001 2PIN / 170MM / AWG22	WX1A74F0-001
DIODE		
D106	LED BLUE SMD KPA-3010PBC	NP1ZKPA3010P
RESISTOR		
R137	CHIP RES. 1/10W J 10 Ω	RRXAJB5Z0100

INVERTER CBA

Ref. No.	Description	Part No.
	INVERTER CBA Consists of the following:	1ESA17931
CAPACITORS		
C501▲	ALUMINUM ELECTROLYTIC CAP 470μF/200V M	CA2D471NC190
C502	CERAMIC CAP. F Z 0.01μF/500V	CCD2JZP0F103
C504▲	CAP METALIZED FILM 0.47μF/275V K	CT2E474DC011
C505▲	CAP METALIZED FILM 0.47μF/275V K	CT2E474DC011
C506	CERAMIC CAP. F Z 0.01μF/500V	CCD2JZP0F103
C509	ELECTROLYTIC CAP. 220μF/200V M	CE2DMZNDL221
C510	FILM CAP.(P) 0.022μF/50V J	CA1J223MS029
C511	CERAMIC CAP.(AX) B J 390pF/50V	CCA1JJT0B391
C512	CERAMIC CAP.(AX) B J 100pF/50V	CCA1JJT0B104
C513	CERAMIC CAP.(AX) F Z 0.1μF/50V	CCA1JZTFZ104
C514	ELECTROLYTIC CAP. 10μF/50V M	CE1JMASDL100
C515	PCB JUMPER D0.6-P5.0	JW5.0T
C516	CAP METALIZED FILM 0.047μF 630V J	CT2K473DT036
C517	CERAMIC CAP. BN 1000pF/2KV	CCD3DKA0B102
C520	FILM CAP.(P) 0.022μF/50V J	CA1J223MS029
C521	SAFETY CAP. 2200pF/250V	CCD2EMA0E222
C522	SAFETY CAP. 2200pF/250V	CCD2EMA0E222
C551	CHIP CERAMIC CAP. F Z 0.01μF/50V	CHD1JZ30F103
C555	CERAMIC CAP. B K 1000pF/500V	CCD2JKS0B102
C556	CERAMIC CAP.(AX) B K 0.01μF/50V	CA1J103TU011
C557▲	CAP ELE STD-85 4700μF/35V SL	CE1GMZNDL472
C558▲	CAP ELE STD-85 4700μF/35V SL	CE1GMZNDL472
C560	ELECTROLYTIC CAP. 0.1μF/50V M	CE1JMASDL0R1
C561	CAP ELE STD-85 4700μF/35V SL	CE1GMZNDL472
C1000	CHIP CERAMIC CAP. B K 1000pF/50V	CHD1JKB0B102
C1002	CHIP CERAMIC CAP. B K 1000pF/50V	CHD1JKB0B102
C1003	CHIP CERAMIC CAP. B K 1000pF/50V	CHD1JKB0B102
C1005	CHIP CERAMIC CAP.(1608) CH J 1000pF/50V	CHD1JJ3CH102
C1006	CHIP CERAMIC CAP. B K 0.047μF/50V	CHD1JKB0B473
C1007	CHIP CERAMIC CAP.(1608) CH J 270pF/50V	CHD1JJ3CH271

Ref. No.	Description	Part No.
C1008	CHIP CERAMIC CAP. F Z 2.2μF/10V	CHD1AZ30F225
C1009	CHIP CERAMIC CAP.(1608) B K 0.1μF/50V	CHD1JK30B104
C1010	CERAMIC CAP.(AX) F Z 0.1μF/50V	CCA1JZTFZ104
C1011	CHIP CERAMIC CAP.(1608) B K 0.47μF/10V	CHD1AK30B474
C1012	CHIP CERAMIC CAP.(1608) B K 0.47μF/10V	CHD1AK30B474
C1013	CHIP CERAMIC CAP. (1608) B K 1μF/16V	CHD1CK30B105
C1014	CHIP CERAMIC CAP.(1608) B K 0.1μF/50V	CHD1JK30B104
C1015	ELECTROLYTIC CAP. 470μF/35V M	CE1GMZNDL471
C1016	CHIP CERAMIC CAP.(1608) B K 0.1μF/50V	CHD1JK30B104
C1017	CHIP CERAMIC CAP.(1608) B K 0.1μF/50V	CHD1JK30B104
C1018	CHIP CERAMIC CAP.(1608) B K 0.1μF/50V	CHD1JK30B104
C1019	CHIP CERAMIC CAP.(1608) B K 0.1μF/50V	CHD1JK30B104
C1020	CHIP CERAMIC CAP.(1608) B K 0.1μF/50V	CHD1JK30B104
C1021	CHIP CERAMIC CAP. B K 1000pF/50V	CHD1JKB0B102
C1023	ELECTROLYTIC CAP. 10μF/50V M	CE1JMASDL100
C1030	ELECTROLYTIC CAP. 47μF/50V M	CE1JMASDL470
C1040	CHIP CERAMIC CAP. B K 1000pF/50V	CHD1JKB0B102
C1041	ELECTROLYTIC CAP. 100μF/35V M	CE1GMASDL101
C1044	CHIP CERAMIC CAP.(1608) B K 1μF/25V	CHD1EK30B105
C1046	CHIP CERAMIC CAP.(1608) B K 1μF/25V	CHD1EK30B105
C1061	CERAMIC CAP. SL D 10pF/3KV	CCD3FDASL100
C1062	CHIP CERAMIC CAP. B K 1200pF/50V	CHD1JK30B122
C1063	CHIP CERAMIC CAP. B K 2200pF/50V	CHD1JKB0B222
C1064	CERAMIC CAP. SL D 10pF/3KV	CCD3FDASL100
C1065	CHIP CERAMIC CAP. B K 1200pF/50V	CHD1JK30B122
C1066	CHIP CERAMIC CAP. B K 2200pF/50V	CHD1JKB0B222
C1067	CHIP CERAMIC CAP. B K 0.01μF/50V	CHD1JKB0B103
C1100	ELECTROLYTIC CAP. 100μF/35V M	CE1GMASDL101
C1101	CHIP CERAMIC CAP.(1608) B K 0.1μF/50V	CHD1JK30B104
C1102	ELECTROLYTIC CAP. 100μF/35V M	CE1GMASDL101
C1103	CHIP CERAMIC CAP.(1608) B K 0.1μF/50V	CHD1JK30B104
C1104	CHIP CERAMIC CAP.(1608) CH J 390pF/50V	CHD1JJ3CH391
C1105	CHIP CERAMIC CAP.(1608) CH J 390pF/50V	CHD1JJ3CH391
C1106	CHIP CERAMIC CAP.(1608) CH J 390pF/50V	CHD1JJ3CH391
C1107	CHIP CERAMIC CAP.(1608) CH J 390pF/50V	CHD1JJ3CH391
C1111	CERAMIC CAP. SL D 10pF/3KV	CCD3FDASL100
C1112	CHIP CERAMIC CAP. B K 1200pF/50V	CHD1JK30B122
C1113	CHIP CERAMIC CAP. B K 2200pF/50V	CHD1JKB0B222
C1114	CERAMIC CAP. SL D 10pF/3KV	CCD3FDASL100
C1115	CHIP CERAMIC CAP. B K 1200pF/50V	CHD1JK30B122
C1116	CHIP CERAMIC CAP. B K 2200pF/50V	CHD1JKB0B222
C1117	CHIP CERAMIC CAP. B K 0.01μF/50V	CHD1JKB0B103
C1161	CERAMIC CAP. SL D 10pF/3KV	CCD3FDASL100
C1162	CHIP CERAMIC CAP. B K 1200pF/50V	CHD1JK30B122
C1163	CHIP CERAMIC CAP. B K 2200pF/50V	CHD1JKB0B222
C1164	CERAMIC CAP. SL D 10pF/3KV	CCD3FDASL100
C1165	CHIP CERAMIC CAP. B K 1200pF/50V	CHD1JK30B122
C1166	CHIP CERAMIC CAP. B K 2200pF/50V	CHD1JKB0B222
C1167	CHIP CERAMIC CAP. B K 0.01μF/50V	CHD1JKB0B103
C1211	CERAMIC CAP. SL D 10pF/3KV	CCD3FDASL100
C1212	CHIP CERAMIC CAP. B K 1200pF/50V	CHD1JK30B122
C1213	CHIP CERAMIC CAP. B K 2200pF/50V	CHD1JKB0B222
C1214	CERAMIC CAP. SL D 10pF/3KV	CCD3FDASL100
C1215	CHIP CERAMIC CAP. B K 1200pF/50V	CHD1JK30B122
C1216	CHIP CERAMIC CAP. B K 2200pF/50V	CHD1JKB0B222
C1217	CHIP CERAMIC CAP. B K 0.01μF/50V	CHD1JKB0B103
C1250	ELECTROLYTIC CAP. 100μF/35V M	CE1GMASDL101
C1251	CHIP CERAMIC CAP.(1608) B K 0.1μF/50V	CHD1JK30B104
C1252	ELECTROLYTIC CAP. 100μF/35V M	CE1GMASDL101
C1253	CHIP CERAMIC CAP.(1608) B K 0.1μF/50V	CHD1JK30B104
C1254	CHIP CERAMIC CAP.(1608) CH J 390pF/50V	CHD1JJ3CH391
C1255	CHIP CERAMIC CAP.(1608) CH J 390pF/50V	CHD1JJ3CH391
C1256	CHIP CERAMIC CAP.(1608) CH J 390pF/50V	CHD1JJ3CH391

Ref. No.	Description	Part No.
C1257	CHIP CERAMIC CAP.(1608) CH J 390pF/50V	CHD1JJ3CH391
C1261	CERAMIC CAP. SL D 10pF/3KV	CCD3FDASL100
C1262	CHIP CERAMIC CAP. B K 1200pF/50V	CHD1JK30B122
C1263	CHIP CERAMIC CAP. B K 2200pF/50V	CHD1JKB0B222
C1264	CERAMIC CAP. SL D 10pF/3KV	CCD3FDASL100
C1265	CHIP CERAMIC CAP. B K 1200pF/50V	CHD1JK30B122
C1266	CHIP CERAMIC CAP. B K 2200pF/50V	CHD1JKB0B222
C1267	CHIP CERAMIC CAP. B K 0.01μF/50V	CHD1JKB0B103
C1300	ELECTROLYTIC CAP. 100μF/35V M	CE1GMASDL101
C1301	CHIP CERAMIC CAP.(1608) B K 0.1μF/50V	CHD1JK30B104
C1302	ELECTROLYTIC CAP. 100μF/35V M	CE1GMASDL101
C1303	CHIP CERAMIC CAP.(1608) B K 0.1μF/50V	CHD1JK30B104
C1311	CERAMIC CAP. SL D 10pF/3KV	CCD3FDASL100
C1312	CHIP CERAMIC CAP. B K 1200pF/50V	CHD1JK30B122
C1313	CHIP CERAMIC CAP. B K 2200pF/50V	CHD1JKB0B222
C1314	CERAMIC CAP. SL D 10pF/3KV	CCD3FDASL100
C1315	CHIP CERAMIC CAP. B K 1200pF/50V	CHD1JK30B122
C1316	CHIP CERAMIC CAP. B K 2200pF/50V	CHD1JKB0B222
C1317	CHIP CERAMIC CAP. B K 0.01μF/50V	CHD1JKB0B103
C1361	CERAMIC CAP. SL D 10pF/3KV	CCD3FDASL100
C1362	CHIP CERAMIC CAP. B K 1200pF/50V	CHD1JK30B122
C1363	CHIP CERAMIC CAP. B K 2200pF/50V	CHD1JKB0B222
C1364	CERAMIC CAP. SL D 10pF/3KV	CCD3FDASL100
C1365	CHIP CERAMIC CAP. B K 1200pF/50V	CHD1JK30B122
C1366	CHIP CERAMIC CAP. B K 2200pF/50V	CHD1JKB0B222
C1367	CHIP CERAMIC CAP. B K 0.01μF/50V	CHD1JKB0B103
C1411	CERAMIC CAP. SL D 10pF/3KV	CCD3FDASL100
C1412	CHIP CERAMIC CAP. B K 1200pF/50V	CHD1JK30B122
C1413	CHIP CERAMIC CAP. B K 2200pF/50V	CHD1JKB0B222
C1414	CERAMIC CAP. SL D 10pF/3KV	CCD3FDASL100
C1415	CHIP CERAMIC CAP. B K 1200pF/50V	CHD1JK30B122
C1416	CHIP CERAMIC CAP. B K 2200pF/50V	CHD1JKB0B222
C1417	CHIP CERAMIC CAP. B K 0.01μF/50V	CHD1JKB0B103
C1500	CHIP CERAMIC CAP.(1608) B K 0.1μF/50V	CHD1JK30B104
C1502	CHIP CERAMIC CAP. B K 0.22μF/10V	CHD1AK30B224
C1550	CHIP CERAMIC CAP.(1608) B K 0.1μF/50V	CHD1JK30B104
C1552	CHIP CERAMIC CAP. B K 0.22μF/10V	CHD1AK30B224
C1600	CHIP CERAMIC CAP.(1608) B K 0.1μF/50V	CHD1JK30B104
C1602	CHIP CERAMIC CAP. B K 0.22μF/10V	CHD1AK30B224
C1604	CHIP CERAMIC CAP.(1608) CH J 390pF/50V	CHD1JJ3CH391
C1605	CHIP CERAMIC CAP.(1608) CH J 390pF/50V	CHD1JJ3CH391
C1606	CHIP CERAMIC CAP.(1608) CH J 390pF/50V	CHD1JJ3CH391
C1607	CHIP CERAMIC CAP.(1608) CH J 390pF/50V	CHD1JJ3CH391
CONNECTORS		
CN501	CONNECTOR B2P3-VH(LF)(SN)	J3VH020JG001
CN552	WIRE ASSEMBLY 001 8PIN / 125MM / AWG26	WX1A71G0-001
CN1050	CONNECTOR/JACK 1747386-1	JB17J02AP002
CN1100	CONNECTOR/JACK 1747386-1	JB17J02AP002
CN1150	CONNECTOR/JACK 1747386-1	JB17J02AP002
CN1200	CONNECTOR/JACK 1747386-1	JB17J02AP002
CN1250	CONNECTOR/JACK 1747386-1	JB17J02AP002
CN1300	CONNECTOR/JACK 1747386-1	JB17J02AP002
CN1350	CONNECTOR/JACK 1747386-1	JB17J02AP002
CN1400	CONNECTOR/JACK 1747386-1	JB17J02AP002
DIODES		
D502▲	DIODE 1N5406	NDLZ001N5406
D503▲	DIODE 1N5406	NDLZ001N5406
D504▲	DIODE 1N5406	NDLZ001N5406
D505▲	DIODE 1N5406	NDLZ001N5406
D507	DIODE 1ZC30(Q)	QDLZ001ZC30Q
D509	DIODE FR154	NDLZ000FR154
D510	SCHOTTKY BARRIEA DIODE 11EQS04	QD4Z011EQS04

Ref. No.	Description	Part No.
D511	FAST RECOVERY DIODE FE201-6	QDLZ00FE2016
D512	SWITCHING DIODE 1SS133(T-77)	QDTZ001SS133
D513	DIODE 1ZC33(Q)	QDLZ001ZC33Q
D554	SWITCHING DIODE 1SS133(T-77)	QDTZ001SS133
D555▲	DIODE SCHOTTKY YG802C10R	QDQZYG802C10
D556	SWITCHING DIODE 1SS133(T-77)	QDTZ001SS133
D557	IC SHUNT REGULATOR KIA431-AT/P	NSZBA0TJY036
D558▲	DIODE SCHOTTKY YG802C10R	QDQZYG802C10
D559	DIODE 1ZC30(Q)	QDLZ001ZC30Q
D560	ZENER DIODE MTZJT-7727B	QDTB00MTZJ27
D563	SWITCHING DIODE 1SS133(T-77)	QDTZ001SS133
D1000	SWITCHING DIODE 1SS133(T-77)	QDTZ001SS133
D1001	SWITCHING DIODE 1SS133(T-77)	QDTZ001SS133
D1002	ZENER DIODE MTZJT-776.2B	QDTB0MTZJ6R2
D1003	ZENER DIODE MTZJT-776.2B	QDTB0MTZJ6R2
D1004	ZENER DIODE MTZJT-776.2B	QDTB0MTZJ6R2
D1005	ZENER DIODE MTZJT-776.2B	QDTB0MTZJ6R2
D1006	SWITCHING DIODE 1SS133(T-77)	QDTZ001SS133
D1007	ZENER DIODE MTZJT-773.3B	QDTB0MTZJ3R3
D1008	ZENER DIODE MTZJT-773.3B	QDTB0MTZJ3R3
D1009	ZENER DIODE MTZJT-773.3B	QDTB0MTZJ3R3
D1011	ZENER DIODE MTZJT-775.6B	QDTB0MTZJ5R6
D1021	SWITCHING DIODE 1SS133(T-77)	QDTZ001SS133
D1042	ZENER DIODE MTZJT-7724B	QDTB00MTZJ24
D1043	SWITCHING DIODE 1SS133(T-77)	QDTZ001SS133
D1045	ZENER DIODE MTZJT-7724B	QDTB00MTZJ24
D1046	SWITCHING DIODE 1SS133(T-77)	QDTZ001SS133
D1060	SWITCHING DIODE 1SS133(T-77)	QDTZ001SS133
D1061	SWITCHING DIODE 1SS133(T-77)	QDTZ001SS133
D1062	SWITCHING DIODE 1SS133(T-77)	QDTZ001SS133
D1063	SWITCHING DIODE 1SS133(T-77)	QDTZ001SS133
D1064	SWITCHING DIODE 1SS133(T-77)	QDTZ001SS133
D1065	SWITCHING DIODE 1SS133(T-77)	QDTZ001SS133
D1066	SWITCHING DIODE 1SS133(T-77)	QDTZ001SS133
D1067	SWITCHING DIODE 1SS133(T-77)	QDTZ001SS133
D1068	SWITCHING DIODE 1SS133(T-77)	QDTZ001SS133
D1110	SWITCHING DIODE 1SS133(T-77)	QDTZ001SS133
D1111	SWITCHING DIODE 1SS133(T-77)	QDTZ001SS133
D1112	SWITCHING DIODE 1SS133(T-77)	QDTZ001SS133
D1113	SWITCHING DIODE 1SS133(T-77)	QDTZ001SS133
D1114	SWITCHING DIODE 1SS133(T-77)	QDTZ001SS133
D1115	SWITCHING DIODE 1SS133(T-77)	QDTZ001SS133
D1116	SWITCHING DIODE 1SS133(T-77)	QDTZ001SS133
D1117	SWITCHING DIODE 1SS133(T-77)	QDTZ001SS133
D1118	SWITCHING DIODE 1SS133(T-77)	QDTZ001SS133
D1160	SWITCHING DIODE 1SS133(T-77)	QDTZ001SS133
D1161	SWITCHING DIODE 1SS133(T-77)	QDTZ001SS133
D1162	SWITCHING DIODE 1SS133(T-77)	QDTZ001SS133
D1163	SWITCHING DIODE 1SS133(T-77)	QDTZ001SS133
D1164	SWITCHING DIODE 1SS133(T-77)	QDTZ001SS133
D1165	SWITCHING DIODE 1SS133(T-77)	QDTZ001SS133
D1166	SWITCHING DIODE 1SS133(T-77)	QDTZ001SS133
D1167	SWITCHING DIODE 1SS133(T-77)	QDTZ001SS133
D1168	SWITCHING DIODE 1SS133(T-77)	QDTZ001SS133
D1210	SWITCHING DIODE 1SS133(T-77)	QDTZ001SS133
D1211	SWITCHING DIODE 1SS133(T-77)	QDTZ001SS133
D1212	SWITCHING DIODE 1SS133(T-77)	QDTZ001SS133
D1213	SWITCHING DIODE 1SS133(T-77)	QDTZ001SS133
D1214	SWITCHING DIODE 1SS133(T-77)	QDTZ001SS133
D1215	SWITCHING DIODE 1SS133(T-77)	QDTZ001SS133
D1216	SWITCHING DIODE 1SS133(T-77)	QDTZ001SS133
D1217	SWITCHING DIODE 1SS133(T-77)	QDTZ001SS133
D1218	SWITCHING DIODE 1SS133(T-77)	QDTZ001SS133

Ref. No.	Description	Part No.
D1260	SWITCHING DIODE 1SS133(T-77)	QDTZ001SS133
D1261	SWITCHING DIODE 1SS133(T-77)	QDTZ001SS133
D1262	SWITCHING DIODE 1SS133(T-77)	QDTZ001SS133
D1263	SWITCHING DIODE 1SS133(T-77)	QDTZ001SS133
D1264	SWITCHING DIODE 1SS133(T-77)	QDTZ001SS133
D1265	SWITCHING DIODE 1SS133(T-77)	QDTZ001SS133
D1266	SWITCHING DIODE 1SS133(T-77)	QDTZ001SS133
D1267	SWITCHING DIODE 1SS133(T-77)	QDTZ001SS133
D1268	SWITCHING DIODE 1SS133(T-77)	QDTZ001SS133
D1310	SWITCHING DIODE 1SS133(T-77)	QDTZ001SS133
D1311	SWITCHING DIODE 1SS133(T-77)	QDTZ001SS133
D1312	SWITCHING DIODE 1SS133(T-77)	QDTZ001SS133
D1313	SWITCHING DIODE 1SS133(T-77)	QDTZ001SS133
D1314	SWITCHING DIODE 1SS133(T-77)	QDTZ001SS133
D1315	SWITCHING DIODE 1SS133(T-77)	QDTZ001SS133
D1316	SWITCHING DIODE 1SS133(T-77)	QDTZ001SS133
D1317	SWITCHING DIODE 1SS133(T-77)	QDTZ001SS133
D1318	SWITCHING DIODE 1SS133(T-77)	QDTZ001SS133
D1360	SWITCHING DIODE 1SS133(T-77)	QDTZ001SS133
D1361	SWITCHING DIODE 1SS133(T-77)	QDTZ001SS133
D1362	SWITCHING DIODE 1SS133(T-77)	QDTZ001SS133
D1363	SWITCHING DIODE 1SS133(T-77)	QDTZ001SS133
D1364	SWITCHING DIODE 1SS133(T-77)	QDTZ001SS133
D1365	SWITCHING DIODE 1SS133(T-77)	QDTZ001SS133
D1366	SWITCHING DIODE 1SS133(T-77)	QDTZ001SS133
D1367	SWITCHING DIODE 1SS133(T-77)	QDTZ001SS133
D1368	SWITCHING DIODE 1SS133(T-77)	QDTZ001SS133
D1410	SWITCHING DIODE 1SS133(T-77)	QDTZ001SS133
D1411	SWITCHING DIODE 1SS133(T-77)	QDTZ001SS133
D1412	SWITCHING DIODE 1SS133(T-77)	QDTZ001SS133
D1413	SWITCHING DIODE 1SS133(T-77)	QDTZ001SS133
D1414	SWITCHING DIODE 1SS133(T-77)	QDTZ001SS133
D1415	SWITCHING DIODE 1SS133(T-77)	QDTZ001SS133
D1416	SWITCHING DIODE 1SS133(T-77)	QDTZ001SS133
D1417	SWITCHING DIODE 1SS133(T-77)	QDTZ001SS133
D1418	SWITCHING DIODE 1SS133(T-77)	QDTZ001SS133
D1500	SWITCHING DIODE 1SS133(T-77)	QDTZ001SS133
D1501	SWITCHING DIODE 1SS133(T-77)	QDTZ001SS133
D1502	SWITCHING DIODE 1SS133(T-77)	QDTZ001SS133
D1503	SWITCHING DIODE 1SS133(T-77)	QDTZ001SS133
D1550	SWITCHING DIODE 1SS133(T-77)	QDTZ001SS133
D1551	SWITCHING DIODE 1SS133(T-77)	QDTZ001SS133
D1552	SWITCHING DIODE 1SS133(T-77)	QDTZ001SS133
D1553	SWITCHING DIODE 1SS133(T-77)	QDTZ001SS133
D1600	SWITCHING DIODE 1SS133(T-77)	QDTZ001SS133
D1601	SWITCHING DIODE 1SS133(T-77)	QDTZ001SS133
D1701	ZENER DIODE MTZJT-7718B	QDTB00MTZJ18
ICS		
IC501	IC UCC28600DR SOIC 8PIN	NSZAA0TTY017
IC509▲	PHOTO COUPLER LTV817MBF	NPEBLTV817MF
IC510▲	PHOTO COUPLER LTV817MBF	NPEBLTV817MF
IC1001	IC INVERTER CONTROLLER OZ9966SN-B1-0-TR/SSO	NSZBA0TTCM06
IC1500	IC BA10324AF-E2	QSZBA0TRM032
IC1550	IC BA10324AF-E2	QSZBA0TRM032
IC1600	IC BA10324AF-E2	QSZBA0TRM032
COILS		
L502▲	FILTER LLBG00ZY2015	LLBG00ZY2015
L503▲	FILTER LLBG00ZY2015	LLBG00ZY2015
TRANSISTORS		
Q501▲	MOS FET 2SK3568(Q)	QQQZ02SK3568
Q502	TRANSISTOR KTC3199-GR-AT/P	NQS4KTC3199P
Q551	TRANSISTOR KTC3199-GR-AT/P	NQS4KTC3199P

Ref. No.	Description	Part No.
Q552	TRANSISTOR KTC3199-GR-AT/P	NQS4KTC3199P
Q1001	TRANSISTOR KTC3199-GR-AT/P	NQS4KTC3199P
Q1002	TRANSISTOR KTC3199-GR-AT/P	NQS4KTC3199P
Q1003	TRANSISTOR KTC3199-GR-AT/P	NQS4KTC3199P
Q1020	TRANSISTOR KTA1267-GR-AT/P	NQS1KTA1267P
Q1100	FET POWER MOS SMD NP22N055SLE-E1-AZ	QF2ZNP22N055
Q1101	FET POWER MOS SMD NP22N055SLE-E1-AZ	QF2ZNP22N055
Q1102	FET POWER MOS SMD NP22N055SLE-E1-AZ	QF2ZNP22N055
Q1103	FET POWER MOS SMD NP22N055SLE-E1-AZ	QF2ZNP22N055
Q1250	FET POWER MOS SMD NP22N055SLE-E1-AZ	QF2ZNP22N055
Q1251	FET POWER MOS SMD NP22N055SLE-E1-AZ	QF2ZNP22N055
Q1252	FET POWER MOS SMD NP22N055SLE-E1-AZ	QF2ZNP22N055
Q1253	FET POWER MOS SMD NP22N055SLE-E1-AZ	QF2ZNP22N055
Q1600	FET POWER MOS SMD NP22N055SLE-E1-AZ	QF2ZNP22N055
Q1601	FET POWER MOS SMD NP22N055SLE-E1-AZ	QF2ZNP22N055
Q1602	FET POWER MOS SMD NP22N055SLE-E1-AZ	QF2ZNP22N055
Q1603	FET POWER MOS SMD NP22N055SLE-E1-AZ	QF2ZNP22N055
Q1701	TRANSISTOR KTA1267-GR-AT/P	NQS1KTA1267P
RESISTORS		
R500A	CEMENT RESISTOR 5W K 3.3 Ω	RW053R3PAK11
R500B	CEMENT RESISTOR 5W K 3.3 Ω	RW053R3PAK11
R500C	CEMENT RESISTOR 5W K 3.3 Ω	RW053R3PAK11
R503▲	CARBON RES. 1/2W J 3.3M Ω	RCX2JZQZ0335
R504	CARBON RES. 1/2W J 3.3M Ω	RCX2JZQZ0335
R505▲	METAL OXIDE FILM RES. 2W J 0.1 Ω	RN02R10KE010
R506	CARBON RES. 1/4W J 10k Ω	RCX4JATZ0103
R507	CARBON RES. 1/4W J 1k Ω	RCX4JATZ0102
R509	PCB JUMPER D0.6-P5.0	JW5.0T
R510▲	CARBON RES. 1/4W J 120k Ω	RCX4JATZ0124
R511	CARBON RES. 1/4W J 120k Ω	RCX4JATZ0124
R512	CARBON RES. 1/4W J 120k Ω	RCX4JATZ0124
R513	CARBON RES. 1/4W J 22 Ω	RCX4JATZ0220
R514	CARBON RES. 1/4W J 22 Ω	RCX4JATZ0220
R515	CARBON RES. 1/4W J 220k Ω	RCX4JATZ0224
R516	CARBON RES. 1/4W J 27k Ω	RCX4JATZ0273
R517▲	CARBON RES. 1/4W J 560k Ω	RCX4JATZ0564
R518	CARBON RES. 1/4W J 560k Ω	RCX4JATZ0564
R519	CARBON RES. 1/4W J 560k Ω	RCX4JATZ0564
R520	METAL OXIDE FILM RES. 3W J 10 Ω	RN03100ZU001
R521	CARBON RES. 1/4W J 330k Ω	RCX4JATZ0334
R522	METAL OXIDE RES. 3W J 18k Ω	RN03183ZU001
R523	PCB JUMPER D0.6-P5.0	JW5.0T
R524	METAL OXIDE RES. 3W J 18k Ω	RN03183ZU001
R551	CHIP RES. 1/10W J 5.6k Ω	RRXAJR5Z0562
R553	CHIP RES. 1/10W J 2.2k Ω	RRXAJR5Z0222
R554	CHIP RES. 1/10W J 22k Ω	RRXAJR5Z0223
R555	CARBON RES. 1/4W J 820 Ω	RCX4JATZ0821
R556	PCB JUMPER D0.6-P5.0	JW5.0T
R557	CHIP RES.(1608) 1/10W F 2.2k Ω	RRXAFR5Z2201
R558	CHIP RES. 1/10W F 6.8k Ω	RRXAFR5Z26801
R559	CHIP RES. 1/10W F 6.8k Ω	RRXAFR5Z26801
R560	CHIP RES. 1/10W F 5.6k Ω	RRXAFR5H5601
R562	CHIP RES. 1/10W J 3.3k Ω	RRXAJR5Z0332
R564	CARBON RES. 1/4W J 2.7k Ω	RCX4JATZ0272
R565	CHIP RES. 1/10W J 10k Ω	RRXAJR5Z0103
R566	METAL OXIDE FILM RES. 2W J 1.5k Ω	RN02152DP004
R567	METAL OXIDE FILM RES. 2W J 1.5k Ω	RN02152DP004
R568	CHIP RES. 1/10W J 5.6k Ω	RRXAJR5Z0562
R571	CHIP RES. 1/10W J 22k Ω	RRXAJR5Z0223
R572	CHIP RES. 1/10W J 3.3k Ω	RRXAJR5Z0332
R1000	CHIP RES. 1/10W J 20k Ω	RRXAJR5Z0203
R1001	CHIP RES. 1/10W J 10k Ω	RRXAJR5Z0103

Ref. No.	Description	Part No.
R1002	CHIP RES. 1/10W J 5.1k Ω	RRXAJR5Z0512
R1003	CHIP RES. 1/10W J 220k Ω	RRXAJR5Z0224
R1005	CHIP RES. 1/10W F 220k Ω	RRXAFR5Z0224
R1006	CARBON RES. 1/4W J 10k Ω	RCX4JATZ0103
R1007	CHIP RES. 1/10W F 1M Ω	RRXAFR5H1004
R1008	CHIP RES. 1/10W J 51k Ω	RRXAJR5Z0513
R1009	CHIP RES. 1/10W F 1M Ω	RRXAFR5H1004
R1010	CHIP RES. 1/10W F 220k Ω	RRXAFR5Z0224
R1011	CHIP RES. 1/10W F 120k Ω	RRXAFR5Z0124
R1012	CHIP RES. 1/10W J 68k Ω	RRXAJR5Z0683
R1013	CHIP RES. 1/10W J 10k Ω	RRXAJR5Z0103
R1014	CARBON RES. 1/4W J 51k Ω	RCX4JATZ0513
R1015	CHIP RES. 1/10W F 5.1k Ω	RRXAFR5Z0512
R1016	CHIP RES. 1/10W J 2.2k Ω	RRXAJR5Z0222
R1019	CHIP RES. 1/10W J 10k Ω	RRXAJR5Z0103
R1020	CHIP RES. 1/10W J 1M Ω	RRXAJR5Z0105
R1040	CHIP RES. 1/10W J 22k Ω	RRXAJR5Z0223
R1041	CHIP RES. 1/10W J 10k Ω	RRXAJR5Z0103
R1042	CHIP RES. 1/10W J 22k Ω	RRXAJR5Z0223
R1043	CHIP RES. 1/10W J 22k Ω	RRXAJR5Z0223
R1044	CHIP RES. 1/10W J 6.8k Ω	RRXAJR5Z0682
R1045	CHIP RES. 1/10W J 47k Ω	RRXAJR5Z0473
R1046	CARBON RES. 1/4W J 6.8k Ω	RCX4JATZ0682
R1047	CHIP RES. 1/10W J 1M Ω	RRXAJR5Z0105
R1048	CHIP RES. 1/10W J 1k Ω	RRXAJR5Z0102
R1050	CHIP RES. 1/10W J 47k Ω	RRXAJR5Z0473
R1051	CARBON RES. 1/4W J 6.8k Ω	RCX4JATZ0682
R1052	CHIP RES. 1/10W J 1M Ω	RRXAJR5Z0105
R1053	CHIP RES. 1/10W J 1k Ω	RRXAJR5Z0102
R1060	CHIP RES. 1/10W J 100k Ω	RRXAJR5Z0104
R1061	CHIP RES. 1/10W J 20k Ω	RRXAJR5Z0203
R1062	CHIP RES. RMC1/067500FTP	RRXAFR5Z7500
R1063	CARBON RES. 1/4W J 5.1k Ω	RCX4JATZ0512
R1064	CHIP RES. 1/10W J 100k Ω	RRXAJR5Z0104
R1065	CHIP RES. 1/10W J 20k Ω	RRXAJR5Z0203
R1066	CHIP RES. RMC1/067500FTP	RRXAFR5Z7500
R1067	CARBON RES. 1/4W J 5.1k Ω	RCX4JATZ0512
R1068	CHIP RES. 1/10W F 6.8k Ω	RRXAFR5Z6801
R1069	CHIP RES. 1/10W F 6.8k Ω	RRXAFR5Z6801
R1070	CHIP RES. 1/10W J 1M Ω	RRXAJR5Z0105
R1071	CHIP RES. 1/10W J 1k Ω	RRXAJR5Z0102
R1100	CHIP RES. 1/10W J 18 Ω	RRXAJR5Z0180
R1101	CHIP RES. 1/10W J 18 Ω	RRXAJR5Z0180
R1102	CHIP RES. 1/10W J 18 Ω	RRXAJR5Z0180
R1103	CHIP RES. 1/10W J 18 Ω	RRXAJR5Z0180
R1104	PCB JUMPER D0.6-P5.0	JW5.0T
R1105	PCB JUMPER D0.6-P5.0	JW5.0T
R1110	CHIP RES. 1/10W J 100k Ω	RRXAJR5Z0104
R1111	CHIP RES. 1/10W J 20k Ω	RRXAJR5Z0203
R1112	CHIP RES. RMC1/067500FTP	RRXAFR5Z7500
R1113	CARBON RES. 1/4W J 5.1k Ω	RCX4JATZ0512
R1114	CHIP RES. 1/10W J 100k Ω	RRXAJR5Z0104
R1115	CHIP RES. 1/10W J 20k Ω	RRXAJR5Z0203
R1116	CHIP RES. RMC1/067500FTP	RRXAFR5Z7500
R1117	CARBON RES. 1/4W J 5.1k Ω	RCX4JATZ0512
R1118	CHIP RES. 1/10W F 6.8k Ω	RRXAFR5Z6801
R1119	CHIP RES. 1/10W F 6.8k Ω	RRXAFR5Z6801
R1120	CHIP RES. 1/10W J 1M Ω	RRXAJR5Z0105
R1121	CHIP RES. 1/10W J 1k Ω	RRXAJR5Z0102
R1160	CHIP RES. 1/10W J 100k Ω	RRXAJR5Z0104
R1161	CHIP RES. 1/10W J 20k Ω	RRXAJR5Z0203
R1162	CHIP RES. RMC1/067500FTP	RRXAFR5Z7500
R1163	CARBON RES. 1/4W J 5.1k Ω	RCX4JATZ0512

Ref. No.	Description	Part No.
R1164	CHIP RES. 1/10W J 100k Ω	RRXAJR5Z0104
R1165	CHIP RES. 1/10W J 20k Ω	RRXAJR5Z0203
R1166	CHIP RES. RMC1/067500FTP	RRXAFR5Z7500
R1167	CARBON RES. 1/4W J 5.1k Ω	RCX4JATZ0512
R1168	CHIP RES. 1/10W F 6.8k Ω	RRXAFR5Z6801
R1169	CHIP RES. 1/10W F 6.8k Ω	RRXAFR5Z6801
R1170	CHIP RES. 1/10W J 1M Ω	RRXAJR5Z0105
R1171	CHIP RES. 1/10W J 1k Ω	RRXAJR5Z0102
R1210	CHIP RES. 1/10W J 100k Ω	RRXAJR5Z0104
R1211	CHIP RES. 1/10W J 20k Ω	RRXAJR5Z0203
R1212	CHIP RES. RMC1/067500FTP	RRXAFR5Z7500
R1213	CARBON RES. 1/4W J 5.1k Ω	RCX4JATZ0512
R1214	CHIP RES. 1/10W J 100k Ω	RRXAJR5Z0104
R1215	CHIP RES. 1/10W J 20k Ω	RRXAJR5Z0203
R1216	CHIP RES. RMC1/067500FTP	RRXAFR5Z7500
R1217	CARBON RES. 1/4W J 5.1k Ω	RCX4JATZ0512
R1218	CHIP RES. 1/10W F 6.8k Ω	RRXAFR5Z6801
R1219	CHIP RES. 1/10W F 6.8k Ω	RRXAFR5Z6801
R1220	CHIP RES. 1/10W J 1M Ω	RRXAJR5Z0105
R1221	CHIP RES. 1/10W J 1k Ω	RRXAJR5Z0102
R1250	CHIP RES. 1/10W J 18 Ω	RRXAJR5Z0180
R1251	CHIP RES. 1/10W J 18 Ω	RRXAJR5Z0180
R1252	CHIP RES. 1/10W J 18 Ω	RRXAJR5Z0180
R1253	CHIP RES. 1/10W J 18 Ω	RRXAJR5Z0180
R1254	PCB JUMPER D0.6-P5.0	JW5.0T
R1255	PCB JUMPER D0.6-P5.0	JW5.0T
R1260	CARBON RES. 1/4W J 100k Ω	RCX4JATZ0104
R1261	CHIP RES. 1/10W J 20k Ω	RRXAJR5Z0203
R1262	CHIP RES. RMC1/067500FTP	RRXAFR5Z7500
R1263	CARBON RES. 1/4W J 5.1k Ω	RCX4JATZ0512
R1264	CHIP RES. 1/10W J 100k Ω	RRXAJR5Z0104
R1265	CHIP RES. 1/10W J 20k Ω	RRXAJR5Z0203
R1266	CHIP RES. RMC1/067500FTP	RRXAFR5Z7500
R1267	CARBON RES. 1/4W J 5.1k Ω	RCX4JATZ0512
R1268	CHIP RES. 1/10W F 6.8k Ω	RRXAFR5Z6801
R1269	CHIP RES. 1/10W F 6.8k Ω	RRXAFR5Z6801
R1270	CHIP RES. 1/10W J 1M Ω	RRXAJR5Z0105
R1271	CHIP RES. 1/10W J 1k Ω	RRXAJR5Z0102
R1300	CHIP RES. 1/10W J 18 Ω	RRXAJR5Z0180
R1301	CHIP RES. 1/10W J 18 Ω	RRXAJR5Z0180
R1302	CHIP RES. 1/10W J 18 Ω	RRXAJR5Z0180
R1303	CHIP RES. 1/10W J 18 Ω	RRXAJR5Z0180
R1310	CHIP RES. 1/10W J 100k Ω	RRXAJR5Z0104
R1311	CHIP RES. 1/10W J 20k Ω	RRXAJR5Z0203
R1312	CHIP RES. RMC1/067500FTP	RRXAFR5Z7500
R1313	CARBON RES. 1/4W J 5.1k Ω	RCX4JATZ0512
R1314	CHIP RES. 1/10W J 100k Ω	RRXAJR5Z0104
R1315	CHIP RES. 1/10W J 20k Ω	RRXAJR5Z0203
R1316	CHIP RES. RMC1/067500FTP	RRXAFR5Z7500
R1317	CARBON RES. 1/4W J 5.1k Ω	RCX4JATZ0512
R1318	CHIP RES. 1/10W F 6.8k Ω	RRXAFR5Z6801
R1319	CHIP RES. 1/10W F 6.8k Ω	RRXAFR5Z6801
R1320	CHIP RES. 1/10W J 1M Ω	RRXAJR5Z0105
R1321	CHIP RES. 1/10W J 1k Ω	RRXAJR5Z0102
R1360	CHIP RES. 1/10W J 100k Ω	RRXAJR5Z0104
R1361	CHIP RES. 1/10W J 20k Ω	RRXAJR5Z0203
R1362	CHIP RES. RMC1/067500FTP	RRXAFR5Z7500
R1363	CARBON RES. 1/4W J 5.1k Ω	RCX4JATZ0512
R1364	CHIP RES. 1/10W J 100k Ω	RRXAJR5Z0104
R1365	CHIP RES. 1/10W J 20k Ω	RRXAJR5Z0203
R1366	CHIP RES. RMC1/067500FTP	RRXAFR5Z7500
R1367	CARBON RES. 1/4W J 5.1k Ω	RCX4JATZ0512
R1368	CHIP RES. 1/10W F 6.8k Ω	RRXAFR5Z6801

Ref. No.	Description	Part No.
R1369	CHIP RES. 1/10W F 6.8k Ω	RRXAFR5Z6801
R1370	CHIP RES. 1/10W J 1M Ω	RRXAJR5Z0105
R1371	CHIP RES. 1/10W J 1k Ω	RRXAJR5Z0102
R1410	CHIP RES. 1/10W J 100k Ω	RRXAJR5Z0104
R1411	CHIP RES. 1/10W J 20k Ω	RRXAJR5Z0203
R1412	CHIP RES. RMC1/067500FTP	RRXAFR5Z7500
R1413	CARBON RES. 1/4W J 5.1k Ω	RCX4JATZ0512
R1414	CHIP RES. 1/10W J 100k Ω	RRXAJR5Z0104
R1415	CHIP RES. 1/10W J 20k Ω	RRXAJR5Z0203
R1416	CHIP RES. RMC1/067500FTP	RRXAFR5Z7500
R1417	CARBON RES. 1/4W J 5.1k Ω	RCX4JATZ0512
R1418	CHIP RES. 1/10W F 6.8k Ω	RRXAFR5Z6801
R1419	CHIP RES. 1/10W F 6.8k Ω	RRXAFR5Z6801
R1420	CHIP RES. 1/10W J 1M Ω	RRXAJR5Z0105
R1421	CHIP RES. 1/10W J 1k Ω	RRXAJR5Z0102
R1500	CHIP RES. 1/10W F 47k Ω	RRXAFR5Z0473
R1501	CHIP RES. 1/10W F 1.0k Ω	RRXAFR5H1001
R1504	CARBON RES. 1/4W J 100k Ω	RCX4JATZ0104
R1505	CHIP RES. 1/10W J 10k Ω	RRXAJR5Z0103
R1506	CHIP RES. 1/10W J 100k Ω	RRXAJR5Z0104
R1507	CHIP RES. 1/10W J 10k Ω	RRXAJR5Z0103
R1508	CHIP RES. 1/10W J 100k Ω	RRXAJR5Z0104
R1509	CHIP RES. 1/10W J 10k Ω	RRXAJR5Z0103
R1510	CHIP RES. 1/10W J 100k Ω	RRXAJR5Z0104
R1511	CHIP RES. 1/10W J 10k Ω	RRXAJR5Z0103
R1550	CHIP RES. 1/10W F 47k Ω	RRXAFR5Z0473
R1551	CHIP RES. 1/10W F 1.0k Ω	RRXAFR5H1001
R1554	CHIP RES. 1/10W J 100k Ω	RRXAJR5Z0104
R1555	CHIP RES. 1/10W J 10k Ω	RRXAJR5Z0103
R1556	CHIP RES. 1/10W J 100k Ω	RRXAJR5Z0104
R1557	CHIP RES. 1/10W J 10k Ω	RRXAJR5Z0103
R1558	CHIP RES. 1/10W J 100k Ω	RRXAJR5Z0104
R1559	CHIP RES. 1/10W J 10k Ω	RRXAJR5Z0103
R1560	CHIP RES. 1/10W J 100k Ω	RRXAJR5Z0104
R1561	CHIP RES. 1/10W J 10k Ω	RRXAJR5Z0103
R1600	CHIP RES. 1/10W F 47k Ω	RRXAFR5Z0473
R1601	CHIP RES. 1/10W F 1.0k Ω	RRXAFR5H1001
R1604	CARBON RES. 1/4W J 100k Ω	RCX4JATZ0104
R1605	CHIP RES. 1/10W J 10k Ω	RRXAJR5Z0103
R1606	CHIP RES. 1/10W J 100k Ω	RRXAJR5Z0104
R1607	CHIP RES. 1/10W J 10k Ω	RRXAJR5Z0103
R1612	CHIP RES. 1/10W J 10k Ω	RRXAJR5Z0103
R1613	CHIP RES. 1/10W J 10k Ω	RRXAJR5Z0103
R1614	PCB JUMPER D0.6-P5.0	JW5.0T
R1615	PCB JUMPER D0.6-P5.0	JW5.0T
R1701	CHIP RES. 1/10W J 1k Ω	RRXAJR5Z0102
R1702	CHIP RES. 1/10W J 2.2k Ω	RRXAJR5Z0222
R1703	CHIP RES. 1/10W J 100 Ω	RRXAJR5Z0101
MISCELLANEOUS		
AC501▲	AC CORD UL 1855MM BLACK	WAC0182LW007
B26	HEAT SINK (EAG) ASSEMBLY A71G0UH	1EM424262
BC501	BEAD INDUCTOR FBR07HA121TB-00	LLBF00ZTU021
BC502	BEAD INDUCTOR FBR07HA121TB-00	LLBF00ZTU021
BC503	BEAD INDUCTOR FBR07HA121TB-00	LLBF00ZTU021
BC552	BEAD INDUCTOR FBR07HA121TB-00	LLBF00ZTU021
BC553	BEAD INDUCTOR FBR07HA121TB-00	LLBF00ZTU021
BC1001	PCB JUMPER D0.6-P5.0	JW5.0T
BC1050	PCB JUMPER D0.6-P10.0	JW10.0T
BC1051	PCB JUMPER D0.6-P10.0	JW10.0T
BC1100	PCB JUMPER D0.6-P10.0	JW10.0T
BC1101	PCB JUMPER D0.6-P10.0	JW10.0T
BC1150	PCB JUMPER D0.6-P10.0	JW10.0T

Ref. No.	Description	Part No.
BC1151	PCB JUMPER D0.6-P10.0	JW10.0T
BC1200	PCB JUMPER D0.6-P10.0	JW10.0T
BC1201	PCB JUMPER D0.6-P10.0	JW10.0T
BC1250	PCB JUMPER D0.6-P10.0	JW10.0T
BC1251	PCB JUMPER D0.6-P10.0	JW10.0T
BC1300	PCB JUMPER D0.6-P10.0	JW10.0T
BC1301	PCB JUMPER D0.6-P10.0	JW10.0T
BC1350	PCB JUMPER D0.6-P5.0	JW5.0T
BC1351	PCB JUMPER D0.6-P5.0	JW5.0T
BC1400	PCB JUMPER D0.6-P10.0	JW10.0T
BC1401	PCB JUMPER D0.6-P10.0	JW10.0T
F501▲	FUSE STC4A125V U/CT	PAGE20CW3402
FC501	CORE FERRITE TOROIDAL HF40T18X10X10	XL04018TE001
FH501	FUSE HOLDER MSF-015 LF (B110)	XH01Z00LY002
FH502	FUSE HOLDER MSF-015 LF (B110)	XH01Z00LY002
GP501▲	GAP. FNR-G3.10D	FAZ000LD6005
J1001	BEAD INDUCTOR FBR07HA121TB-00	LLBF00ZTU021
JS502	PCB JUMPER D0.6-P10.0	JW10.0T
JS503	PCB JUMPER D0.6-P22.5	JW22.5T
JS504	PCB JUMPER D0.6-P20.0	JW20.0T
JS1001	PCB JUMPER D0.6-P11.5	JW11.5T
L6	SCREW B-TIGHT D3X8 BIND HEAD+	GBJB3080
SA502▲	SURGE ABSORBER 470V+10PER	NVQZ10D471KB
T501▲	TRANS POWER ETS49BP193AD	LTT4PCOMS003
T1050	TRANS INVERTER ETJV23ZF2KAC	LTZ2PCOMS005
T1100	TRANS INVERTER ETJV23ZF2KAC	LTZ2PCOMS005
T1150	TRANS INVERTER ETJV23ZF2KAC	LTZ2PCOMS005
T1200	TRANS INVERTER ETJV23ZF2KAC	LTZ2PCOMS005
T1250	TRANS INVERTER ETJV23ZF2KAC	LTZ2PCOMS005
T1300	TRANS INVERTER ETJV23ZF2KAC	LTZ2PCOMS005
T1350	TRANS INVERTER ETJV23ZF2KAC	LTZ2PCOMS005
T1400	TRANS INVERTER ETJV23ZF2KAC	LTZ2PCOMS005

© 2007 Funai Electric Co., Ltd.

All rights reserved. No part of this manual may be reproduced, copied, transmitted, disseminated, transcribed, downloaded or stored in any storage medium, in any form or for any purpose without the express prior written consent of Funai. Furthermore, any unauthorized commercial distribution of this manual or any revision hereto is strictly prohibited.

Information in this document is subject to change without notice. Funai reserves the right to change the content herein without the obligation to notify any person or organization of such changes.

FUNAI with the  design is a registered trademark of Funai Electric Co., Ltd and may not be used in any way without the express written consent of Funai. All other trademarks used herein remain the exclusive property of their respective owners. Nothing contained in this manual should be construed as granting, by implication or otherwise, any license or right to use any of the trademarks displayed herein. Misuse of any trademarks or any other content in this manual is strictly prohibited. Funai shall aggressively enforce its intellectual property rights to the fullest extent of the law.